



Caimi
BREVETTI



Snowsound 吸音板 / 吸音布 產品 2018



SNOWSOUND

Caimi
B R E V E T T I
SNOWSOUND DIVISION

Snowsound awards

I Le innovazioni tecnologiche di Snowsound ed il design dei prodotti realizzati con queste particolari tecnologie hanno ottenuto importanti riconoscimenti a livello internazionale. Tra gli altri riconoscimenti, Snowsound ha ricevuto negli Stati Uniti il premio “International CES Innovations Design and Engineering Awards” considerato il più importante riconoscimento al mondo per l’innovazione nel campo dell’elettronica e dell’Audio/Video, il premio Compasso d’Oro e il premio DesignEuropa Awards, assegnato dall’Ufficio dell’Unione Europea per la proprietà intellettuale (EUIPO).

F Les innovations technologiques de Snowsound et le design des produits réalisés avec ces technologies particulières, ont obtenu d’importants recompenses au niveau international. Parmi les autres, Snowsound a remporté aux Etats-Unis le prix “International CES Innovations Design and Engineering Awards” considéré comme le plus important prix au monde pour l’innovation dans le domaine de l’électronique et de l’audio/vidéo, le prix Compasso d’Oro ADI et le prix DesignEuropa Awards, attribué par l’Office de l’Union Européenne pour la Propriété Intellectuelle (EUIPO).

D Die technologischen Innovationen von Snowsound sowie das Design der mit Hilfe dieser besonderen Technologien erstellten Produkte wurden mit international wichtigen Auszeichnungen prämiert. Unter anderem erhielt Snowsound den Preis “International CES Innovations Design and Engeneering Awards” in U. S. A., weltweit als die wichtigste Auszeichnung im Bereich Elektronik und Audio/Video angesehen, sowie den Preis “Compasso d’oro” und den Preis “DesignEuropa Awards”, der vom Amt der Europäischen Union für Geistiges Eigentum (EUIPO) verliehen wird.

E Las innovaciones tecnológicas de Snowsound y el diseño de los productos realizados con estas tecnologías específicas fueron premiados en el ámbito internacional. Entre otros reconocimientos en Estados Unidos, a Snowsound se le otorgó el premio “International CES Innovations Design and Engineering Awards” que se considera la distinción para la innovación más importante en el mundo para el sector de la electrónica y del Audio/Video. El premio Compasso d’Oro y el premio DesignEuropa Awards de EUIPO (European Union Intellectual Property Office).

EN The technological innovations of Snowsound and the design of products made with these special technologies have achieved major world recognitions. Among other honors, in the United States Snowsound was awarded the “International CES Innovations Design and Engineering Awards” considered the most prestigious award for innovation in the field of electronics and audio/video, the Compasso d’Oro award and the DesignEuropa Awards by EUIPO (European Union Intellectual Property Office).

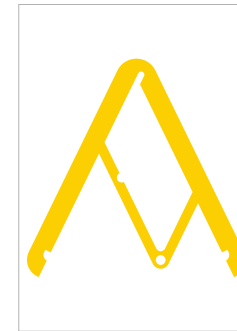

XXIV Compasso d'Oro
(Italy)



DesignEuropa Awards
by EUIPO (European Union
Intellectual Property Office)



International CES
Innovations Design
and Engineering Awards
(U.S.A.)



Trophée de l'Innovation
Bureaux Expo
(France)



German Design Award
Product: Baffle
(Germany)



German Design Award
Product: President
(Germany)



HiP Interior Design
Product: Blade
[U.S.A.]



German Design Award
[Germany]



Product Design Awards
[Dubai, U.A.E.]



Gran Design Etico
International Award
[Italy]



Design Journal
Best of 2015
[U.S.A.]



Best of NeoCon
[U.S.A.]



German Design Award
[Germany]



German Design Award
Product: Analysis software
[Germany]



Ho.Re.Ca.
Innovazione dell'anno
[Italy]



Gran Design Etico
International Award
[Italy]



German Design Award
[Germany]



HiP Interior Design
Product: Sipario
[U.S.A.]



Product Innovation
Merit Award
[U.S.A.]



Best of NeoCon
Product: Diesis
[U.S.A.]



Best of NeoCon
[U.S.A.]



Best of NeoCon
[U.S.A.]



ADI Design Index
[Italy]



Trophée de l'Innovation
Workspace Expo
[France]



Best of NeoCon
Product: Analysis software
[U.S.A.]



Gran Design Etico
International Award
[Italy]



German Design Award
Product: Diesis
[Germany]

INDICE / INDEX



Corner 59/44 page 8



NEW

Snowfix page 36



NEW

Giotto Lux page 55



Snowfront page 14



NEW

Baffle Oversize page 42



Pli Oversize page 56



Snowdesk page 16



Oversize wall page 44



Pli page 58

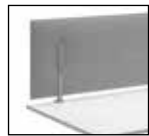

Mitesco Desk page 20

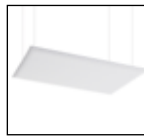

Oversize ceiling page 46



Baffle 59/44 page 60



Pli desk page 28



NEW

Oversize Lux page 48



Tra page 64



Oversize desk page 30



NEW

Giotto Wall page 52



Mitesco page 68



Design Collection page 32

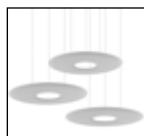

NEW

Giotto Ceiling page 54



Mitesco Easy
Mitesco Magnetic page 72



Mitesco Wall page 74



Flap Ceiling page 102



Cocker page 123



Mitesco Cables page 76



NEW Flap Chain page 106



Palio / Palio Pro page 126



Mitesco Ceiling page 80



V-Flap page 110



Sipario page 130



Mitesco Totem page 82



In page 112



Diesis page 134

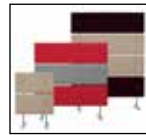

Mitesco Divider page 84



Blade page 114



Bemolle page 136



Flap / Maxiflap page 94



NEW Snowsound Art page 116



NEW Bemolle Lux page 138



Flap Lux page 98



Snowwall page 121



NEW Si Sboccia Si Sboccia Ceiling page 140



Flap Totem page 101



Corista page 122



NEW Snowsofa page 142



NEW Fiber-Textiles page 144

SNOWSOUND

COLORI PANNELLI - PANELS' COLORS - COULEURS PANNEAUX -
COLORES PANELES - PANEELEFARBEN

0001



Bianco - White - Blanc - Blanco - Weiss

8004



Grigio argento - Silver grey - Gris argenté
Gris plata - Silbergrau

8033



Nero - Black - Noir - Negro - Schwarz

7013



Verde Mela - Apple green - Vert Pomme
Verde Manzana - Grüner Apfel

4027



Rosso - Red - Rouge - Rojo - Rot

6071

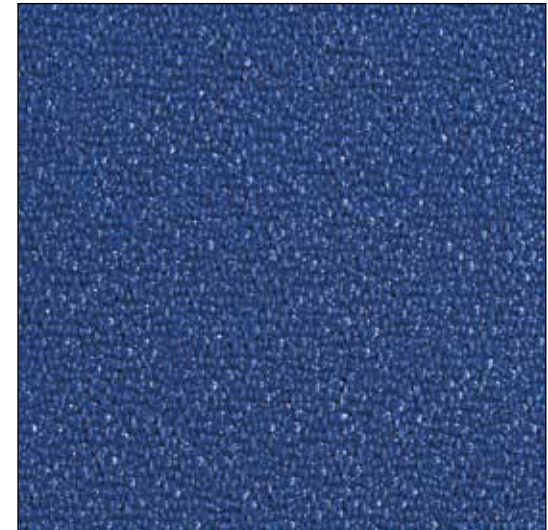

Blu - Blue - Bleu - Azul - Blau

SNOWSOUND

COLORI PANNELLI - PANELS' COLORS - COULEURS PANNEAUX -
COLORES PANELES - PANEELEFARBEN

1008

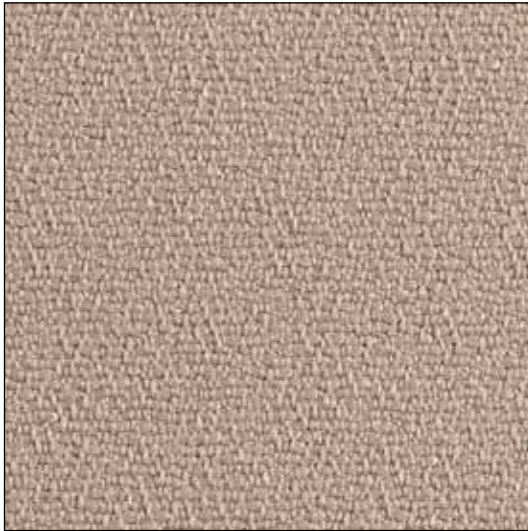

Beige - Beige - Beige - Beige - Beige

2005

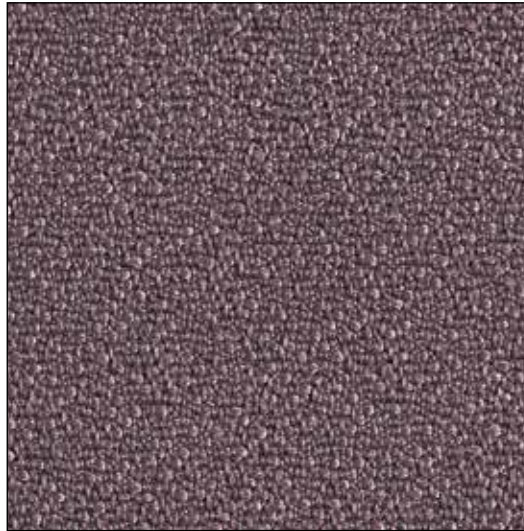

Tortora - Dove-grey - Taupe
Tórtola - Taubengrau

8007



Grigio scuro - Dark grey - Gris foncé - Gris oscuro Dun-
kelgrau

3008

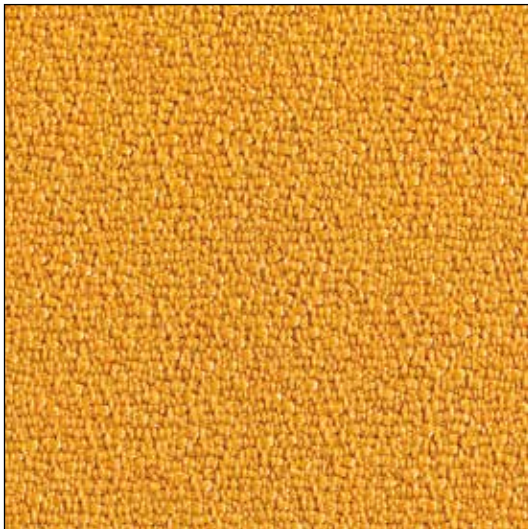

Giallo Sole - Sun yellow - Jaune Soleil
Amarillo Sol - Gelbe Sonne

4030

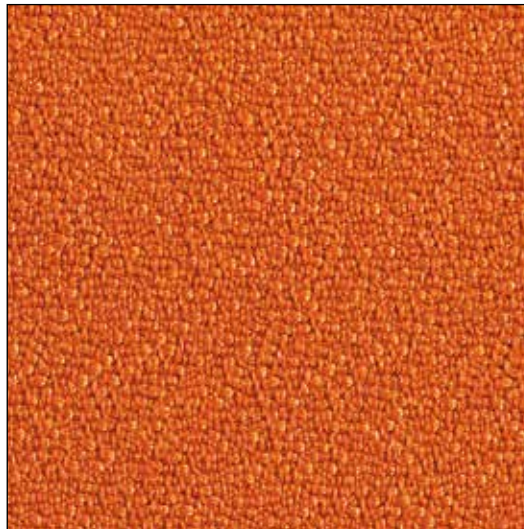

Arancione Carota - Carrot orange - Orange Carotte
Anaranjado Zanahoria - Orange Karotte

7004

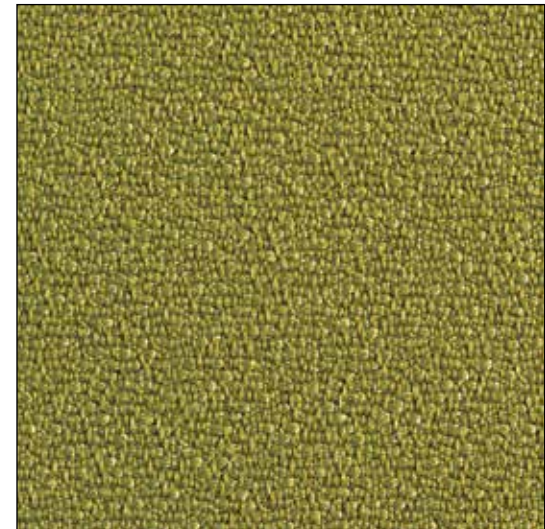

Verde chiaro - Light green - Vert clair - Verde claro -
Hellgrün

PER APPLICAZIONI A SCRIVANIA - DESK MOUNTING - MONTAGE SUR LE BUREAU
MONTAJE SOBRE MESAS DE ESCRITORIO - TISCHBEFESTIGUNG

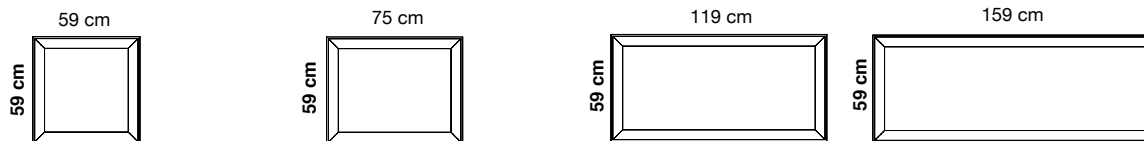

Colore Colour	Codice/Code Prezzo/Price	Codice/Code Prezzo/Price	Codice/Code Prezzo/Price	Codice/Code Prezzo/Price
Bianco White Blanc	0001	7B0606-0001	7B0806-0001	7B1206-0001
Grigio argento Silver grey Gris argenté	8004	7B0606-8004	7B0806-8004	7B1206-8004
Grigio scuro Dark grey Gris foncé	8007	7B0606-8007	7B0806-8007	7B1206-8007
Beige Beige Beige	1008	7B0606-1008	7B0806-1008	7B1206-1008
Tortora Dove-grey Taupe	2005	7B0606-2005	7B0806-2005	7B1206-2005
Giallo Yellow Jaune	3008	7B0606-3008	7B0806-3008	7B1206-3008
Arancione Orange Orange	4030	7B0606-4030	7B0806-4030	7B1206-4030
Rosso Red Rouge	4027	7B0606-4027	7B0806-4027	7B1206-4027
Verde chiaro Light green Vert clair	7004	7B0606-7004	7B0806-7004	7B1206-7004
Verde Green Vert	7013	7B0606-7013	7B0806-7013	7B1206-7013
Blu Blue Bleu	6071	7B0606-6071	7B0806-6071	7B1206-6071
Nero Black Noir	8033	7B0606-8033	7B0806-8033	7B1206-8033

Pannello con imbottitura interna in poliester a **densità variabile** Snowsound® Technology. Rivestimento esterno in tessuto di poliester Trevira CS®.

Panel with polyester internal padding with Snowsound® Technology **variable density**. Polyester covering in Trevira CS® fabric.

Panneau avec rembourrage interne en polyester à **densité variable** Snowsound® Technology. Revêtement externe en tissu de polyester Trevira CS®.

Panel con acolchado interior de poliéster de **densidad variable** Snowsound® Technology. Revestimiento exterior de tejido de poliéster Trevira CS®.

Paneel mit Polyester-Füllmaterial von **unterschiedlicher Dichte** Snowsound® Technology. Polyester-Bezug aus Trevira CS®-Material.

PER APPLICAZIONI A SCRIVANIA - DESK MOUNTING - MONTAGE SUR LE BUREAU
MONTAJE SOBRE MESAS DE ESCRITORIO - TISCHBEFESTIGUNG

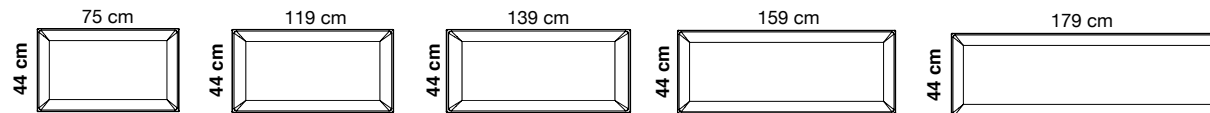

Colore Colour	Codice/Code Prezzo/Price	Codice/Code Prezzo/Price	Codice/Code Prezzo/Price	Codice/Code Prezzo/Price	Codice/Code Prezzo/Price	
Bianco White Blanc	0001	7B0408-0001	7B0412-0001	7B0414-0001	7B0416-0001	7B0418-0001
Grigio argento Silver grey Gris argenté	8004	7B0408-8004	7B0412-8004	7B0414-8004	7B0416-8004	7B0418-8004
Grigio scuro Dark grey Gris foncé	8007	7B0408-8007	7B0412-8007	7B0414-8007	7B0416-8007	7B0418-8007
Beige Beige Beige	1008	7B0408-1008	7B0412-1008	7B0414-1008	7B0416-1008	7B0418-1008
Tortora Dove-grey Taupe	2005	7B0408-2005	7B0412-2005	7B0414-2005	7B0416-2005	7B0418-2005
Giallo Yellow Jaune	3008	7B0408-3008	7B0412-3008	7B0414-3008	7B0416-3008	7B0418-3008
Arancione Orange Orange	4030	7B0408-4030	7B0412-4030	7B0414-4030	7B0416-4030	7B0418-4030
Rosso Red Rouge	4027	7B0408-4027	7B0412-4027	7B0414-4027	7B0416-4027	7B0418-4027
Verde chiaro Light green Vert clair	7004	7B0408-7004	7B0412-7004	7B0414-7004	7B0416-7004	7B0418-7004
Verde Green Vert	7013	7B0408-7013	7B0412-7013	7B0414-7013	7B0416-7013	7B0418-7013
Blu Blue Bleu	6071	7B0408-6071	7B0412-6071	7B0414-6071	7B0416-6071	7B0418-6071
Nero Black Noir	8033	7B0408-8033	7B0412-8033	7B0414-8033	7B0416-8033	7B0418-8033

Pannello con imbottitura interna in poliester a **densità variabile** Snowsound® Technology. Rivestimento esterno in tessuto di poliester Trevira CS®.

Panel with polyester internal padding with Snowsound® Technology **variable density**. Polyester covering in Trevira CS® fabric.

Panneau avec rembourrage interne en polyester à **densité variable** Snowsound® Technology. Revêtement externe en tissu de polyester Trevira CS®.

Panel con acolchado interior de poliéster de **densidad variable** Snowsound® Technology. Revestimiento exterior de tejido de poliéster Trevira CS®.

Paneel mit Polyester-Füllmaterial von **unterschiedlicher Dichte** Snowsound® Technology. Polyester-Bezug aus Trevira CS®-Material.

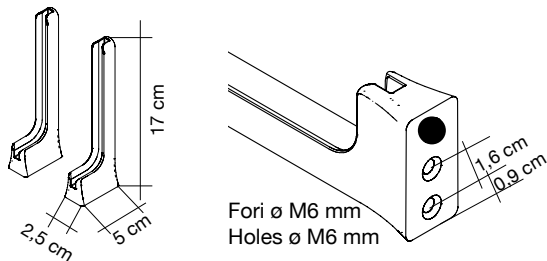
**7B400-GA**

Grigio argento
Silver grey
Gris argenté
Gris plata
Silbergrau

1 coppia / 1 pair
1 paire / 1 pare
1 Paar

Coppia attacchi in zama verniciata con polveri epossidiche per fissaggio sopra il piano della scrivania tramite viti (non incluse). **Per pannelli Corner 59 pag. 8 e Corner 44 pag. 9.**

Pair of brackets in powder-coated zamac to be fixed on the desk top with screws (not included). **For panels 59 page 8 and Corner 44 page 9.**

Paire d'étriers en zamak peint époxy pour fixation sur le bureau par des vis (pas incluses). **Pour panneaux Corner 59 page 8 et Corner 44 page 9.**

Par de embrazaderas de zamac recubierto epoxi para fijacion sobre el plan del escritorio por medio de tornillos (no incluidos). **Para panels Corner 59 pag. 8 y Corner 44 pag. 9.**

1 Paar Halterungen aus pulverbeschichtetem Zamac zur Befestigung auf der Tischplatte durch Schrauben (nicht inkludiert). **Für Paneele: Corner 59 Seite 8 und Corner 44 Seite 9.**

7B400-BO

Bianco opaco
Mat white
Blanc mat
Blanco mate
Mattweiß

1 coppia / 1 pair
1 paire / 1 pare
1 Paar

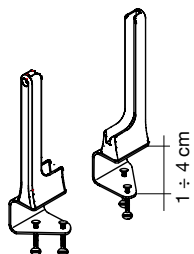
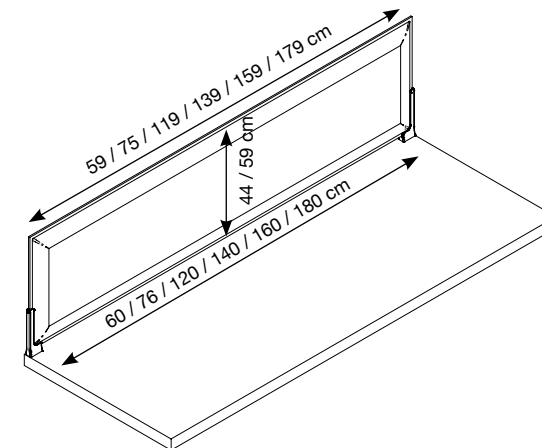
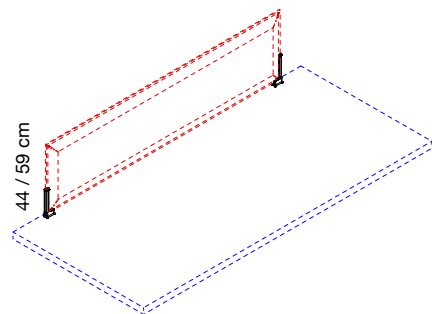
**7B4100-GA**

Grigio argento
Silver grey
Gris argenté
Gris plata
Silbergrau

1 coppia / 1 pair
1 paire / 1 pare
1 Paar

Coppia attacchi in zama con morsetto in acciaio verniciato con polveri epossidiche per fissaggio al piano della scrivania. **Per pannelli Corner 59 pag. 8 e Corner 44 pag. 9.**

Pair of brackets with clamp in powder-coated steel and zamac for connection to the desk top. **For panels: Corner 59 page 8 and Corner 44 page 9.**

Paire d'étriers en zamak avec étau en acier peint époxy pour fixation au bureau. **Pour panneaux Corner 59 page 8 et Corner 44 page 9.**

Par de embrazaderas de zamac con sujetador de acero recubiertos epoxi para fijacion al plan del escritorio. **Para paneles Corner 59 pag 8 y Corner 44 page 9.**

1 Paar Halterungen aus pulverbeschichtetem Stahl und Zamac mit Klemmen zur Befestigung an der Tischplatte. **Für Paneele: Corner 59 Seite 8 und Corner 44 Seite 9.**

7B4100-BO

Bianco opaco
Mat white
Blanc mat
Blanco mate
Mattweiß

1 coppia / 1 pair
1 paire / 1 pare
1 Paar

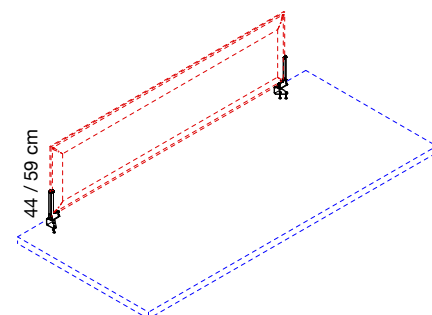

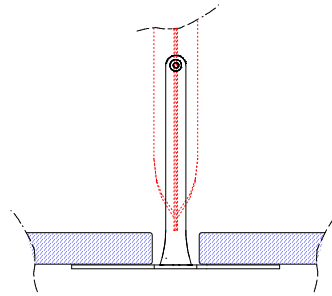
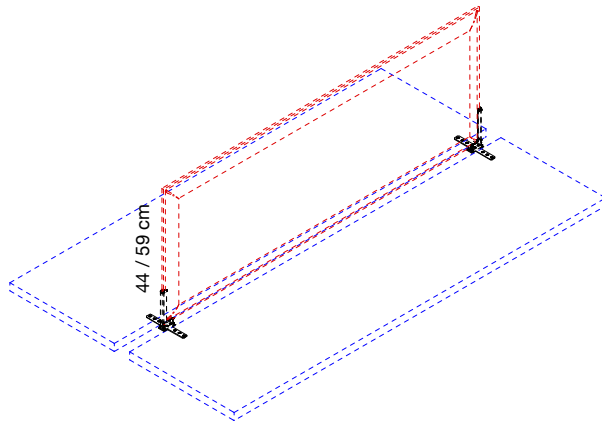
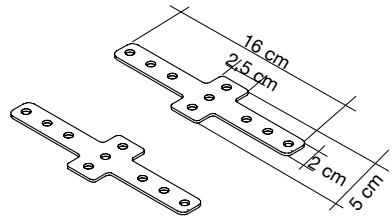

7B414-GA

Grigio argento
 Silver grey
 Gris argenté
 Gris plata
 Silbergrau

1 coppia / 1 pair
 1 paire / 1 pare
 1 Paar

7B414-BO

Bianco opaco
 Mat white
 Blanc mat
 Blanco mate
 Mattweiß

1 coppia / 1 pair
 1 paire / 1 pare
 1 Paar

Supporti per attacchi in acciaio da utilizzare con attacchi 7B400-GA / 7B400-BO.

Steel supports for brackets 7B400-GA / 7B400-BO.

Supports à utiliser avec étriers 7B400-GA / 7B400-BO.

Soportes para fijaciones de acero. Utilizacion con embrazaderas 7B400-GA / 7B400-BO.

Stahlbefestigungen zur Verwendung mit den Halterungen 7B400-GA / 7B400-BO.

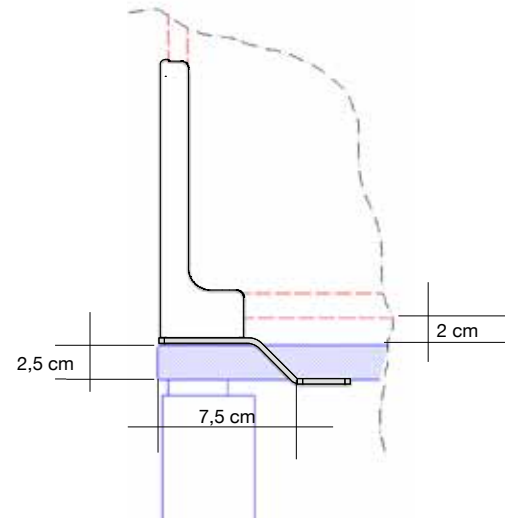
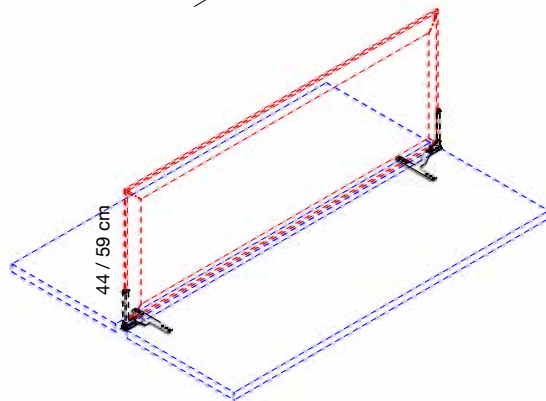
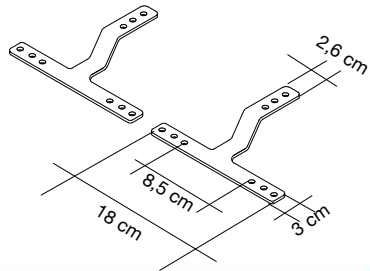

7B415-GA

Grigio argento
 Silver grey
 Gris argenté
 Gris plata
 Silbergrau

1 coppia / 1 pair
 1 paire / 1 pare
 1 Paar

7B415-BO

Bianco opaco
 Mat white
 Blanc mat
 Blanco mate
 Mattweiß

1 coppia / 1 pair
 1 paire / 1 pare
 1 Paar

Supporti per attacchi in acciaio da utilizzare con attacchi 7B400-GA / 7B400-BO.

Steel supports for brackets 7B400-GA / 7B400-BO.

Supports à utiliser avec étriers 7B400-GA / 7B400-BO.

Soportes para fijaciones de acero. Utilizacion con embrazaderas 7B400-GA / 7B400-BO.

Stahlbefestigungen zur Verwendung mit den Halterungen 7B400-GA / 7B400-BO.

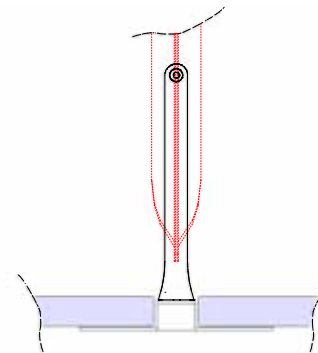

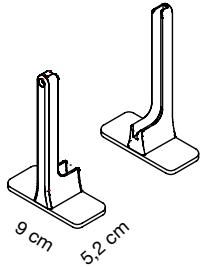

7B4120-GA
Grigio argento
Silver grey
Gris argenté
Gris plata
Silbergrau

1 coppia / 1 pair
1 paire / 1 pare
1 Paar

Coppia staffe con base in acciaio verniciato con polveri epossidiche per fissaggio al piano della scrivania. Fissaggio al piano obbligatorio a cura del cliente. Scegliere il tipo di fissaggio / incollaggio idoneo alla superficie del piano. **Per pannelli Corner 59 pag. 8 e Corner 44 pag. 9.**

Pair of brackets with base in powder coated steel for fixing to the desk top. Mandatory fastening to the top at customer's care. Choose the most suitable connection/gluing for the surface. **For panels: Corner 59 page 8 and Corner 44 page 9.**

Paire d'étriers avec base en acier peint en époxy à fixer au dessus du bureau. Fixation au dessus obligatoire de la part du client. Choisir le type d'accrochage/collage indiqué pour à la surface du dessus. **Pour panneaux Corner 59 page 8 et Corner 44 page 9.**

Par de abrazaderas con base de acero recubierto epoxi para fijación al plan del escritorio. Enganche al plano obligatorio por parte del cliente. Elegir el tipo de sujetador / enlace lo mas adecuado para la superficie del plano. **Para paneles Corner 59 pag. 8 y Corner 44 pag. 9.**

1 Paar Halterungen mit Standfüßen aus pulverbeschichtetem Stahl zur Befestigung auf der Tischplatte. Befestigung durch den Kunden unbedingt erforderlich. Wählen Sie die am besten geeignete Art der Verbindung/Verklebung für die betreffende Oberfläche. **Für Paneele: Corner 59 Seite 8 und Corner 44 Seite 9.**

7B4120-BO
Bianco opaco
Mat white
Blanc mat
Blanco mate
Mattweiß

1 coppia / 1 pair
1 paire / 1 pare
1 Paar

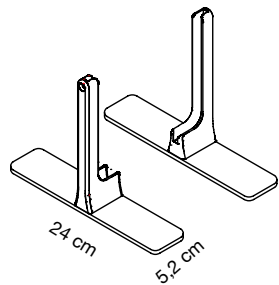
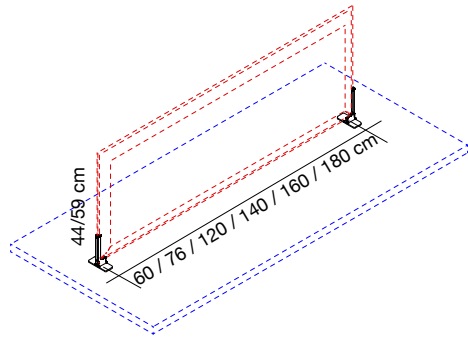

7B4140-GA
Grigio argento
Silver grey
Gris argenté
Gris plata
Silbergrau

1 coppia / 1 pair
1 paire / 1 pare
1 Paar

Coppia staffe con base in acciaio verniciato con polveri epossidiche per appoggio al piano della scrivania. **Per pannelli Corner 59 pag. 8 e Corner 44 pag. 9.**

Pair of brackets with base in powder coated steel for desk top stand. **For panels: Corner 59 page 8 and Corner 44 page 9.**

Paire d'étriers avec base en acier peint en époxy à poser sur le dessus du bureau.

Pour panneaux Corner 59 page 8 et Corner 44 page 9.

Par de abrazaderas con base de acero recubierto epoxi para apoyar al escritorio.

Para paneles Corner 59 pag. 8 y Corner 44 pag. 9.

Paar Halterungen mit Standfüßen aus pulverbeschichtetem Stahl zur Aufstellung auf der Tischplatte.

Für Paneele: Corner 59 Seite 8 und Corner 44 Seite 9.

7B4140-BO
Bianco opaco
Mat white
Blanc mat
Blanco mate
Mattweiß

1 coppia / 1 pair
1 paire / 1 pare
1 Paar

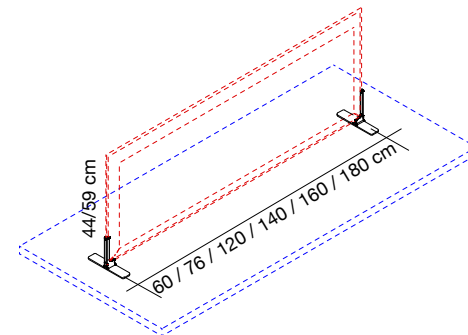

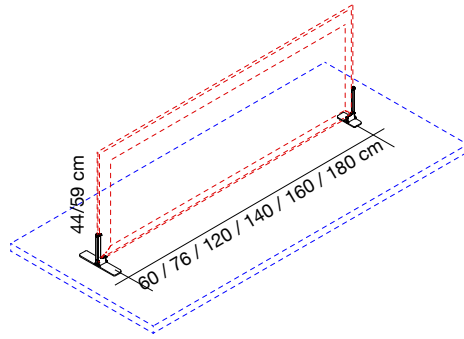
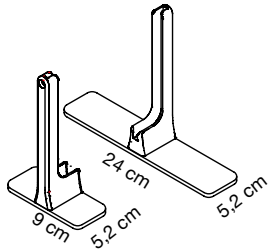

7B4130-GA

Grigio argento
Silver grey
Gris argenté
Gris plata
Silbergrau

1 coppia / 1 pair
1 paire / 1 pare
1 Paar

7B4130-BO

Bianco opaco
Mat white
Blanc mat
Blanco mate
Mattweiß

1 coppia / 1 pair
1 paire / 1 pare
1 Paar

Coppia staffe con base in acciaio verniciato con polveri epossidiche per appoggio al piano della scrivania.
Per pannelli Corner 59 pag. 8 e Corner 44 pag. 9.

Pair of brackets with base in powder coated steel for desk top stand. **For panels: Corner 59 page 8 and Corner 44 page 9.**

Paire d'étriers avec base en acier peint en époxy à poser sur le dessus du bureau.

Pour panneaux Corner 59 page 8 et Corner 44 page 9.

Par de embrazaderas con base de acero recubierto epoxi para apoyar al escritorio.

Para panel Corner 59 pag. 8 y Corner 44 pag. 9.

Paar Halterungen mit Standfüßen aus pulverbeschichtetem Stahl zur Aufstellung auf der Tischplatte.

Für Paneele: Corner 59 Seite 8 und Corner 44 Seite 9.

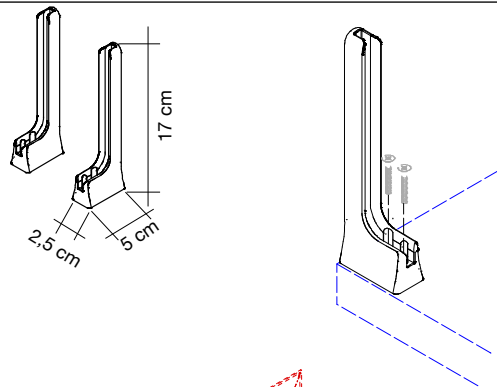

7B401-GA

Grigio argento
Silver grey
Gris argenté
Gris plata
Silbergrau

1 coppia / 1 pair
1 paire / 1 pare
1 Paar

Coppia attacchi in zama verniciata con polveri epossidiche per fissaggio sopra il piano della scrivania tramite viti (non incluse). **Per pannelli Corner 59 pag. 8 e Corner 44 pag. 9.**

Pair of brackets in powder-coated zamac to be fixed on the desk top with screws (not included). **For panels: Corner 59 page 8 and Corner 44 page 9.**

Paire d'étriers en zamak peint époxy pour fixation sur le bureau par des vis (pas incluses). **Pour panneaux Corner 59 page 8 et Corner 44 page 9.**

7B401-BO

Bianco opaco
Mat white
Blanc mat
Blanco mate
Mattweiß

1 coppia / 1 pair
1 paire / 1 pare
1 Paar

Par de embrazaderas de zamac recubierto epoxi para fijacion sobre el plan del escritorio por medio de tornillos (no incluydos). **Para panels Corner 59 pag. 8 y Corner 44 pag 9.**

1 Paar Halterungen aus pulverbeschichtetem Zamac zur Befestigung auf der Tischplatte durch Schrauben (nicht inkludiert). **Für Paneele: Corner 59 Seite 8 und Corner 44 Seite 9.**

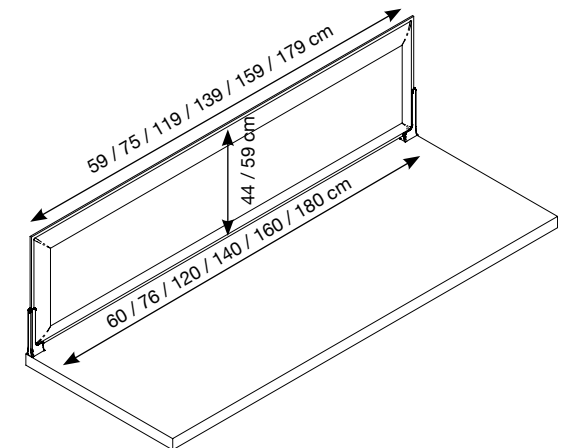
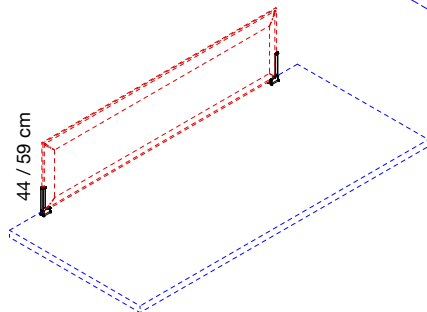

PER APPLICAZIONI A SCRIVANIA - DESK MOUNTING - MONTAGE SUR LE BUREAU
MONTAJE SOBRE MESAS DE ESCRITORIO - TISCHBEFESTIGUNG

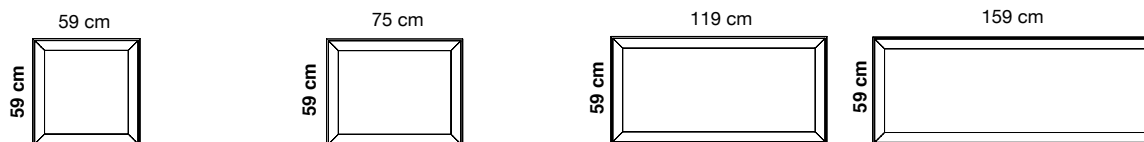

Colore Colour	Codice/Code Prezzo/Price	Codice/Code Prezzo/Price	Codice/Code Prezzo/Price	Codice/Code Prezzo/Price	
Bianco White Blanc	0001	7S066-0001	7S086-0001	7S126-0001	7S166-0001
Grigio argento Silver grey Gris argenté	8004	7S066-8004	7S086-8004	7S126-8004	7S166-8004
Grigio scuro Dark grey Gris foncé	8007	7S066-8007	7S086-8007	7S126-8007	7S166-8007
Beige Beige Beige	1008	7S066-1008	7S086-1008	7S126-1008	7S166-1008
Tortora Dove-grey Taupe	2005	7S066-2005	7S086-2005	7S126-2005	7S166-2005
Giallo Yellow Jaune	3008	7S066-3008	7S086-3008	7S126-3008	7S166-3008
Arancione Orange Orange	4030	7S066-4030	7S086-4030	7S126-4030	7S166-4030
Rosso Red Rouge	4027	7S066-4027	7S086-4027	7S126-4027	7S166-4027
Verde chiaro Light green Vert clair	7004	7S066-7004	7S086-7004	7S126-7004	7S166-7004
Verde Green Vert	7013	7S066-7013	7S086-7013	7S126-7013	7S166-7013
Blu Blue Bleu	6071	7S066-6071	7S086-6071	7S126-6071	7S166-6071
Nero Black Noir	8033	7S066-8033	7S086-8033	7S126-8033	7S166-8033

Pannello con imbottitura interna in poliester a **densità variabile** Snowsound® Technology. Rivestimento esterno in tessuto di poliester Trevira CS®.

Panel with polyester internal padding with Snowsound® Technology **variable density**. Polyester covering in Trevira CS® fabric.

Panneau avec rembourrage interne en polyester à **densité variable** Snowsound® Technology. Revêtement externe en tissu de polyester Trevira CS®.

Panel con acolchado interior de poliéster de **densidad variable** Snowsound® Technology. Revestimiento exterior de tejido de poliéster Trevira CS®.

Paneel mit Polyester-Füllmaterial von **unterschiedlicher Dichte** Snowsound® Technology. Polyester-Bezug aus Trevira CS®-Material.

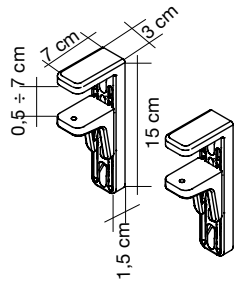

7S310-GA

Grigio argento
Silver grey
Gris argenté
Gris plata
Silbergrau

1 coppia / 1 pair
1 paire / 1 pare
1 Paar

Coppia attacchi con morsetto regolabile in alluminio e acciaio verniciato con polveri epossidiche per fissaggio al piano della scrivania. **Per pannelli Snowfront pag. 14.**

Pair of brackets with adjustable clamp in powder-coated steel and aluminium for connection to the desk top. **For Snowfront panels page 14.**

7S310-BO

Bianco opaco
Mat white
Blanc mat
Blanco mate
Mattweiß

1 coppia / 1 pair
1 paire / 1 pare
1 Paar

Paire d'étriers avec étau réglable en acier et aluminium peint époxy pour fixation au bureau. **Pour panneaux Snowfront page 14.**

Par de embrazaderas con sujetador ajustable en acero y aluminio recubierto epoxi para fijacion al plan del escritorio. **Para panels Snowfront pag. 14.**

1 Paar Halterungen aus pulverbeschichtetem Stahl und Aluminium mit einstellbare Klemmen zur Befestigung an der Tischplatte. **Für Snowfront Paneele, Seite 14.**

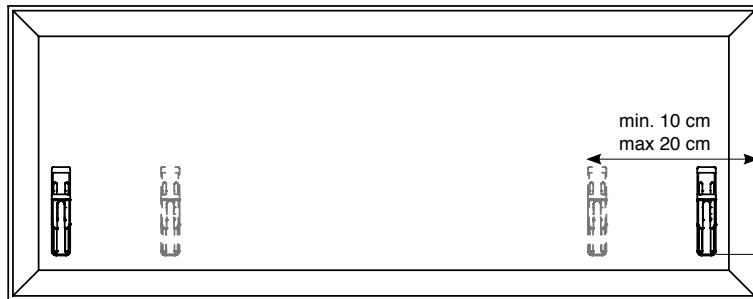
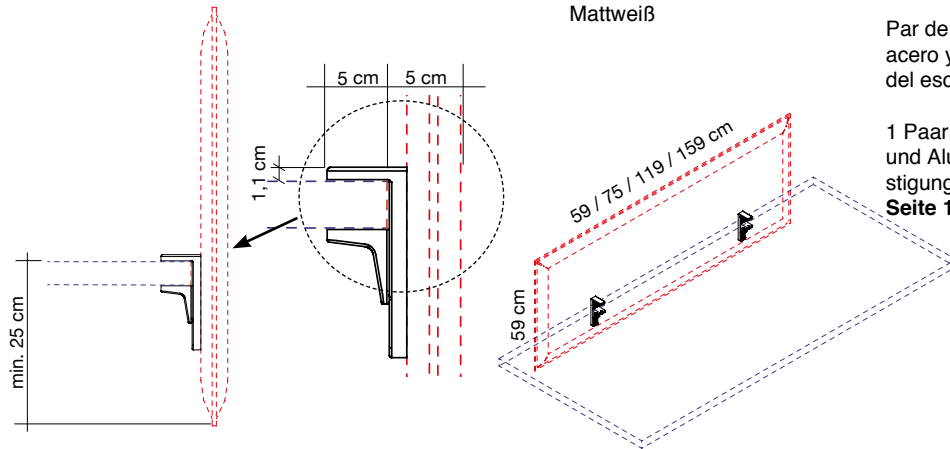

I morsetti possono essere applicati lungo il pannello.

The clamps can be positioned along the panel.

Les étriers peuvent être appliqués le long du panneau.

Los embrazaderas pueden ser posicionados a lo largo del panel.

Die Klemmen können beliebig entlang des Paneels angebracht werden.

min. 10 cm

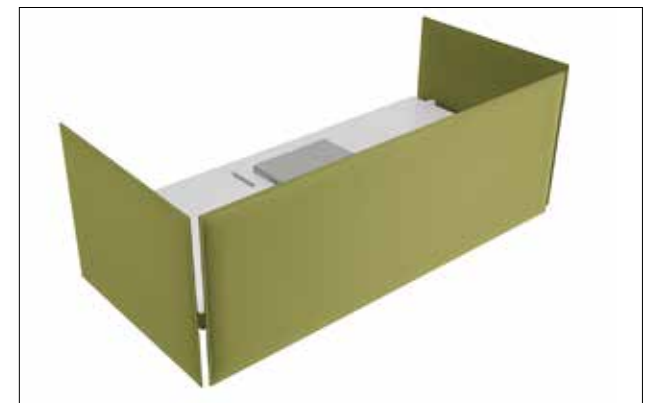
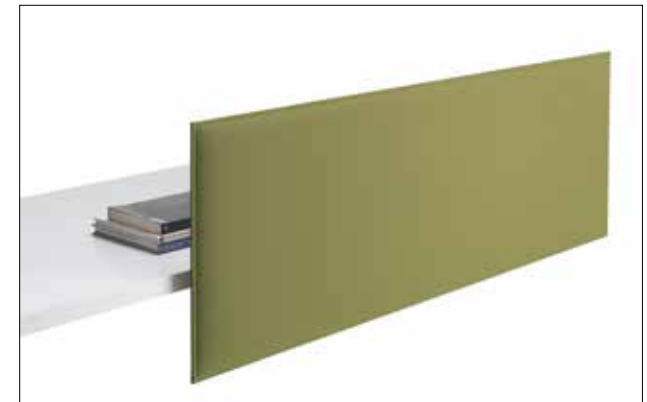

PER APPLICAZIONI A SCRIVANIA - DESK MOUNTING - MONTAGE SUR LE BUREAU
MONTAJE SOBRE MESAS DE ESCRITORIO - TISCHBEFESTIGUNG

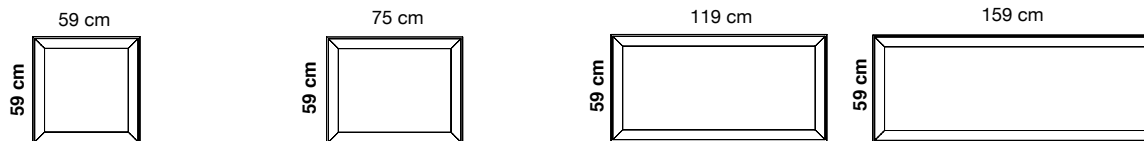

Colore Colour	Codice/Code Prezzo/Price	Codice/Code Prezzo/Price	Codice/Code Prezzo/Price	Codice/Code Prezzo/Price	
Bianco White Blanc	0001	7S066-0001	7S086-0001	7S126-0001	7S166-0001
Grigio argento Silver grey Gris argenté	8004	7S066-8004	7S086-8004	7S126-8004	7S166-8004
Grigio scuro Dark grey Gris foncé	8007	7S066-8007	7S086-8007	7S126-8007	7S166-8007
Beige Beige Beige	1008	7S066-1008	7S086-1008	7S126-1008	7S166-1008
Tortora Dove-grey Taupe	2005	7S066-2005	7S086-2005	7S126-2005	7S166-2005
Giallo Yellow Jaune	3008	7S066-3008	7S086-3008	7S126-3008	7S166-3008
Arancione Orange Orange	4030	7S066-4030	7S086-4030	7S126-4030	7S166-4030
Rosso Red Rouge	4027	7S066-4027	7S086-4027	7S126-4027	7S166-4027
Verde chiaro Light green Vert clair	7004	7S066-7004	7S086-7004	7S126-7004	7S166-7004
Verde Green Vert	7013	7S066-7013	7S086-7013	7S126-7013	7S166-7013
Blu Blue Bleu	6071	7S066-6071	7S086-6071	7S126-6071	7S166-6071
Nero Black Noir	8033	7S066-8033	7S086-8033	7S126-8033	7S166-8033

Pannello con imbottitura interna in poliester a **densità variabile** Snowsound® Technology. Rivestimento esterno in tessuto di poliester Trevira CS®.

Panel with polyester internal padding with Snowsound® Technology **variable density**. Polyester covering in Trevira CS® fabric.

Panneau avec rembourrage interne en polyester à **densité variable** Snowsound® Technology. Revêtement externe en tissu de polyester Trevira CS®.

Panel con acolchado interior de poliéster de **densidad variable** Snowsound® Technology. Revestimiento exterior de tejido de poliéster Trevira CS®.

Panel mit Polyester-Füllmaterial von **unterschiedlicher Dichte** Snowsound® Technology. Polyester-Bezug aus Trevira CS®-Material.

1



- 1) Posizionare le staffe cod. 7S511-GA / 7S511-BO / 7S1100-GA / 7S1100-BO
- 1) Position the brackets code 7S511-GA / 7S511-BO / 7S1100-GA / 7S1100-BO
- 1) Positionnez les étriers réf. 7S511-GA / 7S511-BO / 7S1100-GA / 7S1100-BO
- 1) Colocar los soportes cod. 7S511-GA / 7S511-BO / 7S1100-GA / 7S1100-BO
- 1) Positionieren Sie die Halterungen Art. Nr 7S111-GA / 7S111-BO / 7S1100-GA / 7S1100-BO

2 / 3

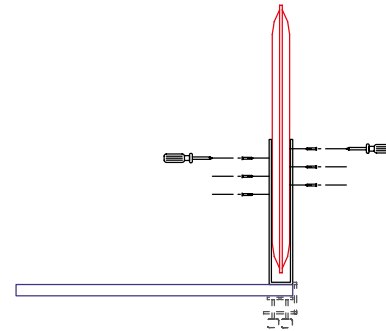

2 e 3) Avvitare le staffe cod 7S511-GA / 7S511-BO / 7S1100-GA / 7S1100-BO direttamente al pannello e applicare la copertura in tecnopolimero.

2 and 3) Directly screw the brackets code 7S511-GA / 7S511-BO / 7S1100-GA / 7S1100-BO to the panels and put on the hi-tech polymer front cover.

2 et 3) Vissez les supports réf. 7S511-GA / 7S511-BO / 7S1100-GA / 7S1100-BO directement au panneau et appliquez les couvertures en technopolymère.

2 y 3) Atornillar los soportes cod. 7S511-GA / 7S511-BO / 7S1100-GA / 7S1100-BO directamente al panel y aplicar las coberturas en tecnopolimero.

2 und 3) Schrauben Sie die Halterungen Art. 7S511-GA / 7S511-BO / 7S1100-GA / 7S1100-BO direkt an das Paneel und befestigen Sie die vordere Abdeckung aus Hi-Tech-Polymer.

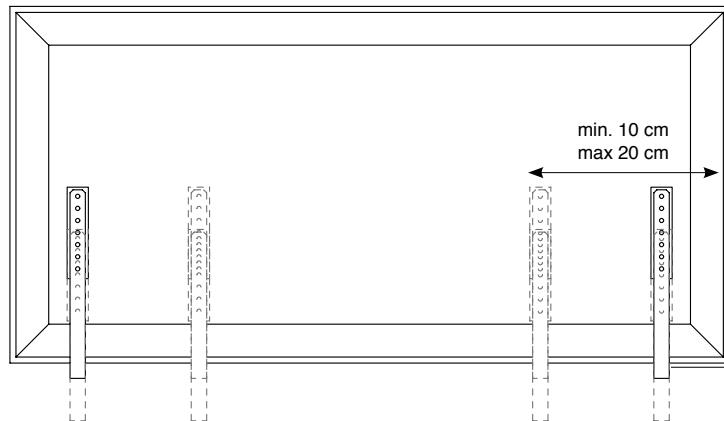

Le staffe possono essere applicate lungo il pannello.

The brackets can be positioned along the panel.

Les supports peuvent être appliqués le long du panneau.

Los soportes pueden ser posicionados a lo largo del panel.

Die Halterungen können beliebig entlang des Paneels angebracht werden.

min. 10 cm
max 20 cm

min. 0,5 cm
max 5 cm

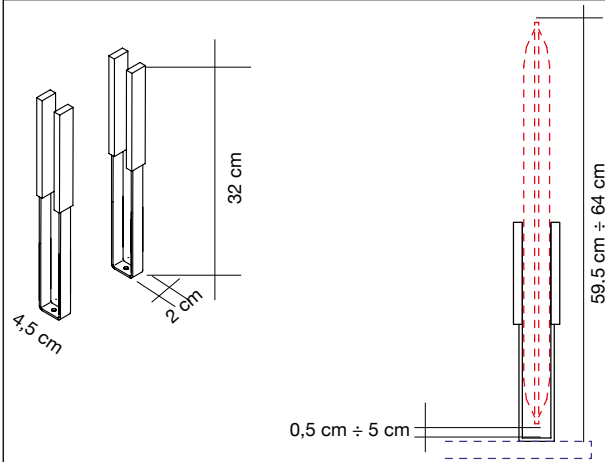
**7S511-GA**

Grigio argento
Silver grey
Gris argenté
Gris plata
Silbergrau

1 coppia / 1 pair
1 paire / 1 pare
1 Paar

Coppia staffe in acciaio verniciato con polveri epossidiche per fissaggio sopra il piano della scrivania tramite viti (non incluse). Attacchi al pannello Snowdesk e coperture in tecnopolimero grigio o bianco. **Per pannelli Snowdesk pag. 16.**

Pair of brackets in powder-coated steel to be fixed on the desk top with screws (not included). Snowdesk panel connections and front covers in grey or white high-tech polymer. **For Snowdesk panels page 16.**

7S511-BO

Bianco opaco
Mat white
Blanc mat
Blanco mate
Mattweiß

1 coppia / 1 pair
1 paire / 1 pare
1 Paar

Paire d'étriers en acier peint époxy pour fixation sur le bureau par des vis (pas incluses). Jonctions au panneau Snowdesk et couvertures en technopolymère gris ou blanc. **Pour panneaux Snowdesk page 16.**

Par de abrazaderas de acero recubierto epoxi para fijación sobre el plan del escritorio por medio de tornillos (no incluydos). Enganches al panel Snowdesk y coberturas de polímero gris o blanco. **Para panels Snowdesk pag. 16.**

1 Paar Halterungen aus pulverbeschichtetem Stahl zur Befestigung auf der Tischplatte durch Schrauben (nicht inkludiert). Snowdesk-Panelbefestigungen und Abdeckungen aus grauem oder weissem Technopolymer. **Für Snowdesk Paneele, Seite 16.**

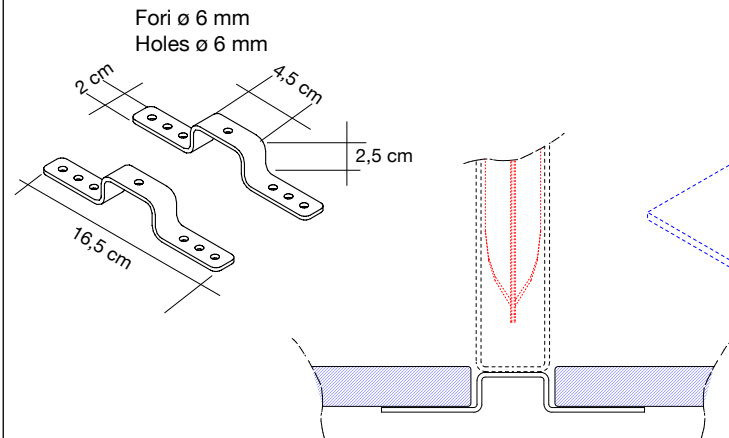
**7S100-GA**

Grigio argento
Silver grey
Gris argenté
Gris plata
Silbergrau

1 coppia / 1 pair
1 paire / 1 pare
1 Paar

Da utilizzare con staffe 7S511-GA / 7S511-BO.

To be used with brackets 7S511-GA / 7S511-BO.

Utiliser avec étriers 7S511-GA / 7S511-BO.

Utilización con abrazaderas 7S511-GA / 7S511-BO.

7S100-BO

Bianco opaco
Mat white
Blanc mat
Blanco mate
Mattweiß

1 coppia / 1 pair
1 paire / 1 pare
1 Paar

Zur Verwendung mit den Halterungen 7S511-GA / 7S511-BO.

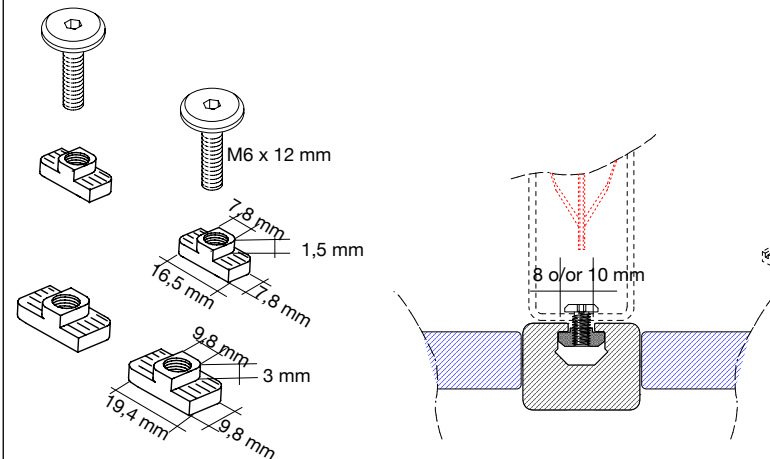
**7S120**

2 coppie / 2 pairs
2 paires / 2 pare
2 Paar

Dadi e viti per profili in alluminio con cava da 8 o 10 mm.

Da utilizzare con staffe 7S511-GA / 7S511-BO.

Nuts and screws for aluminum profiles with hollow 8 or 10 mm. To be used with brackets 7S511-GA / 7S511-BO.

Écrous et vis pour profils en aluminium avec fente de 8 ou 10 mm. À utiliser avec étriers 7S511-GA / 7S511-BO

Tuercas y tornillos para perfiles de aluminio con huecos 8 o 10mm. Para ser utilizado con soportes 7S511-GA / 7S511-BO.

Muttern und Schrauben für Aluminium-Profil mit Nut zu 8 oder 10 mm. Mit Halterungen 7S511-GA / 7S511-BO zu verwenden.

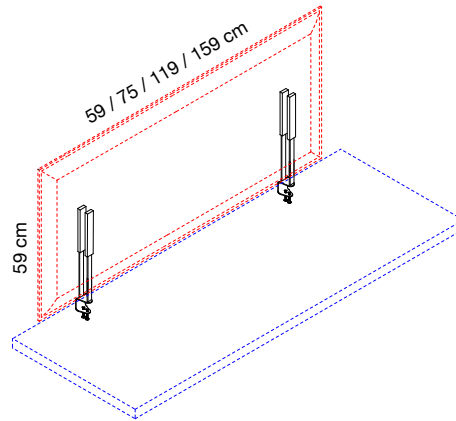
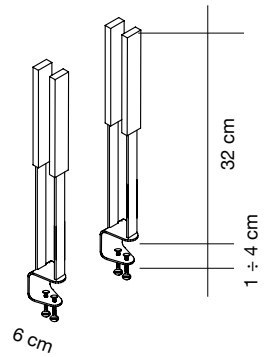

7S1100-GA

Grigio argento
Silver grey
Gris argenté
Gris plata
Silbergrau

1 coppia / 1 pair
1 paire / 1 pare
1 Paar

Coppia staffe con morsetto in acciaio verniciato con polveri epossidiche per fissaggio al piano della scrivania.
Attacchi al pannello Snowdesk e coperture in tecnopolimero grigio o bianco. **Per pannelli Snowdesk pag. 16.**

7S1100-BO

Bianco opaco
Mat white
Blanc mat
Blanco mate
Mattweiß

1 coppia / 1 pair
1 paire / 1 pare
1 Paar

Pair of brackets with clamp in powder-coated steel for connection to the desk top.

Snowdesk panel connections and front covers in grey or white high-tech polymer. **For Snowdesk panels page 16.**

Paire d'étriers avec étau en acier peint époxy pour fixation au bureau. Jonctions au panneau Snowdesk et couvertures en technopolymère gris ou blanc. **Pour panneaux Snowdesk page 16.**

Par de embrazaderas con sujetador en acero recubierto epoxi para fijacion al plan del escritorio. Enganches al panel Snowdesk y coberturas de polímero gris o blanco. **Para panels Snowdesk pag. 16.**

1 Paar Halterungen aus pulverbeschichtetem Stahl mit Klemmen zur Befestigung an der Tischplatte.
Snowdesk-Panelbefestigungen und Abdeckungen aus grauem oder weissem Technopolymer. **Für Snowdesk Paneele, Seite 16.**

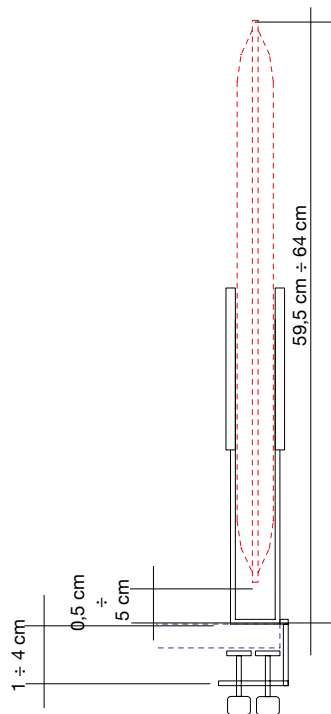

PER APPLICAZIONI A SCRIVANIA - DESK MOUNTING - MONTAGE SUR LE BUREAU - MONTAJE SOBRE MESAS DE ESCRITORIO - TISCHBEFESTIGUNG

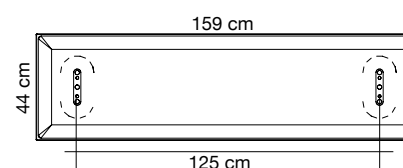
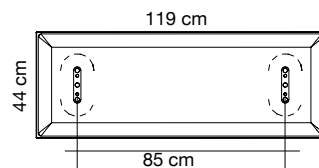
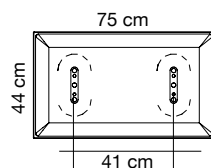

Colore Colour	Codice/Code Prezzo/Price	Codice/Code Prezzo/Price	Codice/Code Prezzo/Price	
Bianco White Blanc	0001	7M084-0001	7M124-0001	7M164-0001
Grigio argento Silver grey Gris argenté	8004	7M084-8004	7M124-8004	7M164-8004
Grigio scuro Dark grey Gris foncé	8007	7M084-8007	7M124-8007	7M164-8007
Beige Beige Beige	1008	7M084-1008	7M124-1008	7M164-1008
Tortora Dove-grey Taupe	2005	7M084-2005	7M124-2005	7M164-2005
Giallo Yellow Jaune	3008	7M084-3008	7M124-3008	7M164-3008
Arancione Orange Orange	4030	7M084-4030	7M124-4030	7M164-4030
Rosso Red Rouge	4027	7M084-4027	7M124-4027	7M164-4027
Verde chiaro Light green Vert clair	7004	7M084-7004	7M124-7004	7M164-7004
Verde Green Vert	7013	7M084-7013	7M124-7013	7M164-7013
Blu Blue Bleu	6071	7M084-6071	7M124-6071	7M164-6071
Nero Black Noir	8033	7M084-8033	7M124-8033	7M164-8033

Pannello con imbottitura interna in poliester a **densità variabile** Snowsound® Technology. Rivestimento esterno in tessuto di poliester Trevira CS®.

Panel with polyester internal padding with Snowsound® Technology **variable density**. Polyester covering in Trevira CS® fabric.

Panneau avec rembourrage interne en polyester à **densité variable** Snowsound® Technology. Revêtement externe en tissu de polyester Trevira CS®.

Panel con acolchado interior de poliéster de **densidad variable** Snowsound® Technology. Revestimiento exterior de tejido de poliéster Trevira CS®.

Paneel mit Polyester-Füllmaterial von **unterschiedlicher Dichte** Snowsound® Technology. Polyester-Bezug aus Trevira CS®-Material.

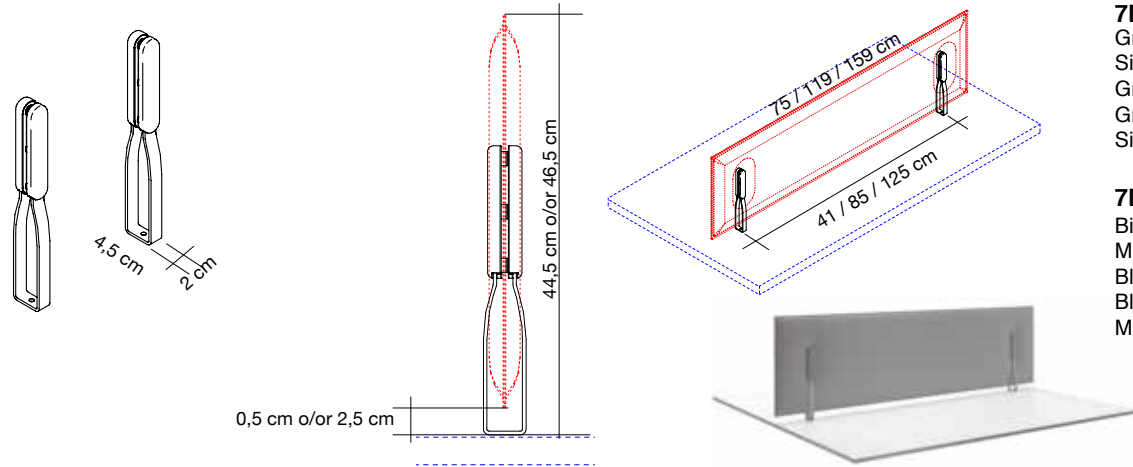

7M511-GA

Grigio argento
Silver grey
Gris argenté
Gris plata
Silbergrau

1 coppia / 1 pair
1 paire / 1 pare
1 Paar

7M511-BO

Bianco opaco
Mat white
Blanc mat
Blanco mate
Mattweiß

1 coppia / 1 pair
1 paire / 1 pare
1 Paar

Coppia staffe in acciaio verniciato con polveri epossidiche per fissaggio sopra il piano della scrivania tramite viti (non incluse). Attacchi al pannello Mitesco e coperture in tecnopolimero grigio o bianco. **Per pannelli Mitesco Desk pag. 20.**

Pair of brackets in powder-coated steel to be fixed on the desk top with screws (not included). Mitesco Panel connections and front covers in grey or white high-tech polymer. **For Mitesco Desk panels page 20.**

Paire d'étriers en acier peint époxy pour fixation sur le bureau par des vis (pas incluses). Jonctions au panneau Mitesco et couvertures en technopolymère gris ou blanc. **Pour panneaux Mitesco Desk page 20.**

Par de abrazaderas de acero recubierto epoxi para fijación sobre el plan del escritorio por medio de tornillos (no incluidos). Enganches al panel Mitesco y coberturas de polímero gris o blanco. **Para panels Mitesco Desk pag. 20.**

1 Paar Halterungen aus pulverbeschichtetem Stahl zur Befestigung auf der Tischplatte durch Schrauben (nicht inkludiert). Mitesco-Panelbefestigungen und Abdeckungen aus grauem oder weissem Technopolymer. **Für Mitesco Desk Paneele, Seite 20.**

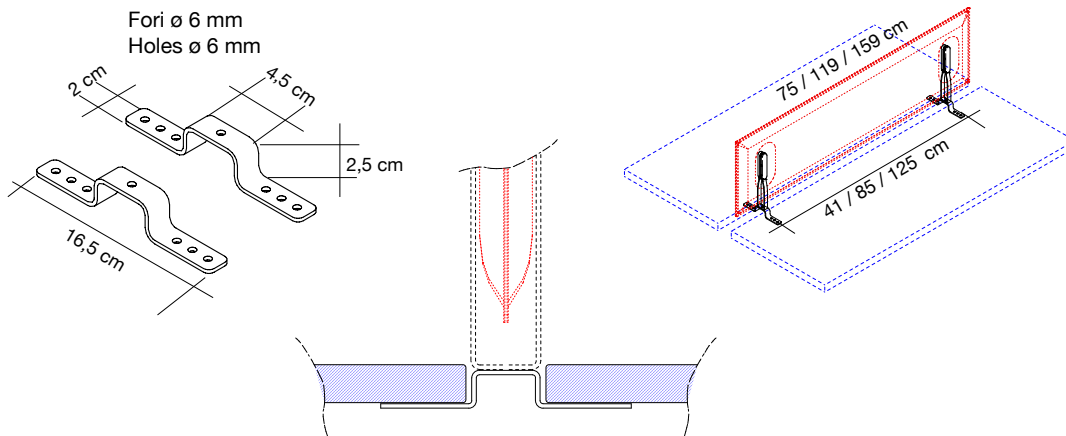

7S100-GA

Grigio argento
Silver grey
Gris argenté
Gris plata
Silbergrau

1 coppia / 1 pair
1 paire / 1 pare
1 Paar

7S100-BO

Bianco opaco
Mat white
Blanc mat
Blanco mate
Mattweiß

1 coppia / 1 pair
1 paire / 1 pare
1 Paar

Da utilizzare con staffe 7M511-GA / 7M511-BO.

To be used with brackets 7M511-GA / 7M511-BO.

Utiliser avec étriers 7M511-GA / 7M511-BO.

Utilización con abrazaderas 7M511-GA / 7M511-BO.

Zur Verwendung mit den Halterungen 7M511-GA / 7M511-BO.

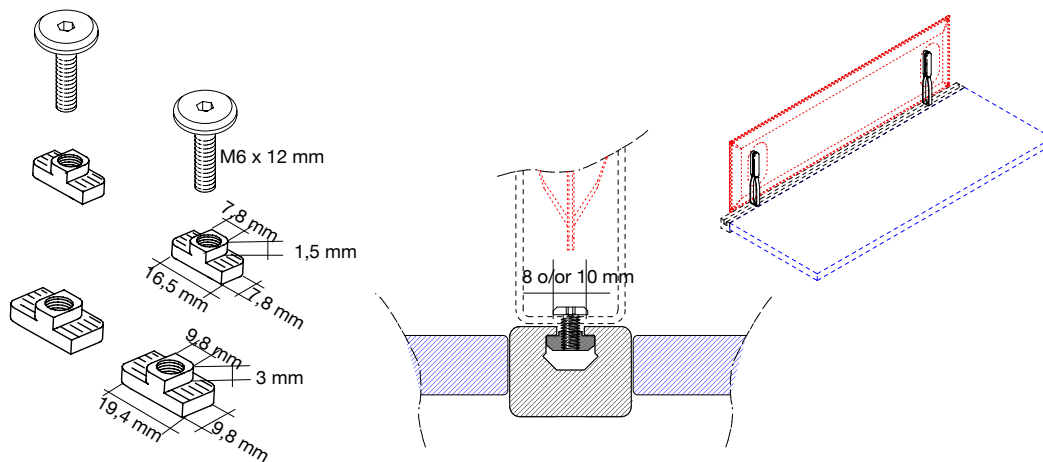

7S120

2 coppie / 2 pairs
2 paires / 2 pare
2 Paar

Dadi e viti per profili in alluminio con cava da 8 o 10 mm.

Da utilizzare con staffe 7M511-GA / 7M511-BO.

Nuts and screws for aluminum profiles with hollow 8 or 10 mm. To be used with brackets 7M511-GA / 7M511-BO.

Écrous et vis pour profils en aluminium avec fente de 8 ou 10 mm. À utiliser avec étriers 7M511-GA / 7M511-BO.

Tuercas y tornillos para perfiles de aluminio con huecos 8 o 10 mm. Utilización con abrazaderas 7M511-GA / 7M511-BO.

Muttern und Schrauben für Aluminium-Profile mit Nut zu 8 oder 10 mm. Mit Halterungen 7M511-GA / 7M511-BO zu verwenden.

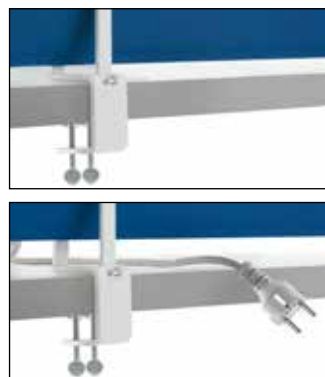
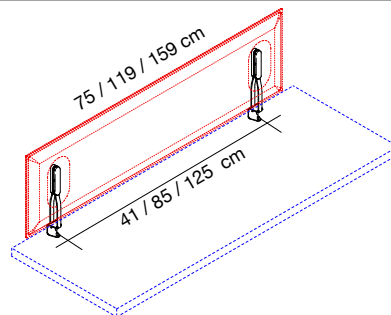
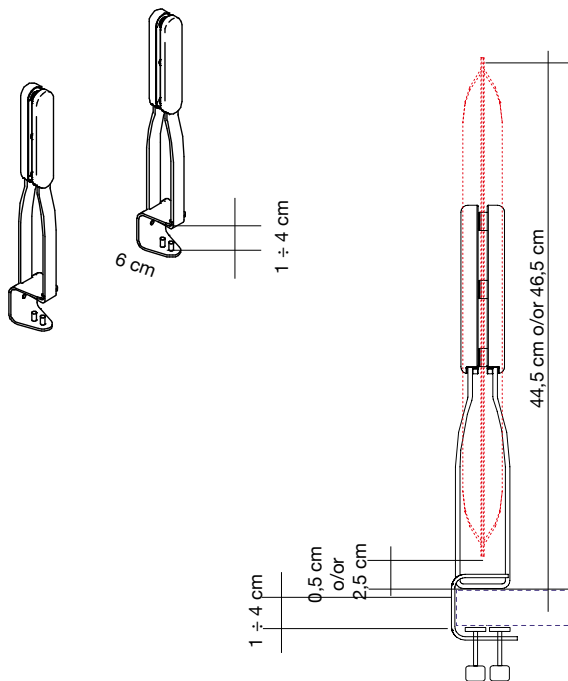
**7M5100-GA**

Grigio argento
Silver grey
Gris argenté
Gris plata
Silbergrau

1 coppia / 1 pair
1 paire / 1 pare
1 Paar

7M5100-BO

Bianco opaco
Mat white
Blanc mat
Blanco mate
Mattweiß

1 coppia / 1 pair
1 paire / 1 pare
1 Paar

Coppia staffe con morsetto in acciaio verniciato con polveri epossidiche per fissaggio al piano della scrivania. Attacchi al pannello Mitesco e coperture in tecnopolimero grigio o bianco. **Per pannelli Mitesco Desk pag. 20.**

Pair of brackets with clamp in powder-coated steel for connection to the desk top. Mitesco panel connections and front covers in grey or white high-tech polymer. **For Mitesco Desk panels page 20.**

Paire d'étriers avec étai en acier peint époxy pour fixation au bureau. Jonctions au panneau Mitesco et couvertures en technopolymère gris ou blanc. **Pour panneaux Mitesco Desk page 20.**

Par de abrazaderas con sujetador de acero recubierto epoxi para fijación al plan del escritorio. Enganches al panel Mitesco y coberturas de polímero gris o blanco. **Para panels Mitesco Desk pag. 20.**

1 Paar Halterungen aus pulverbeschichtetem Stahl mit Klemmen zur Befestigung an der Tischplatte. Mitesco-Paneelbefestigungen und Abdeckungen aus grauem oder weissem Technopolymer. **Für Mitesco Desk Paneele, Seite 20.**

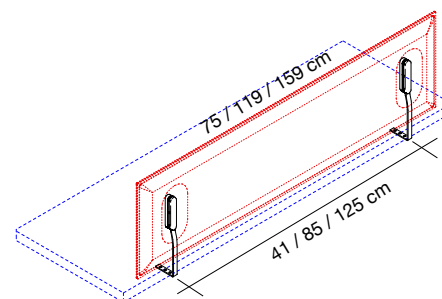
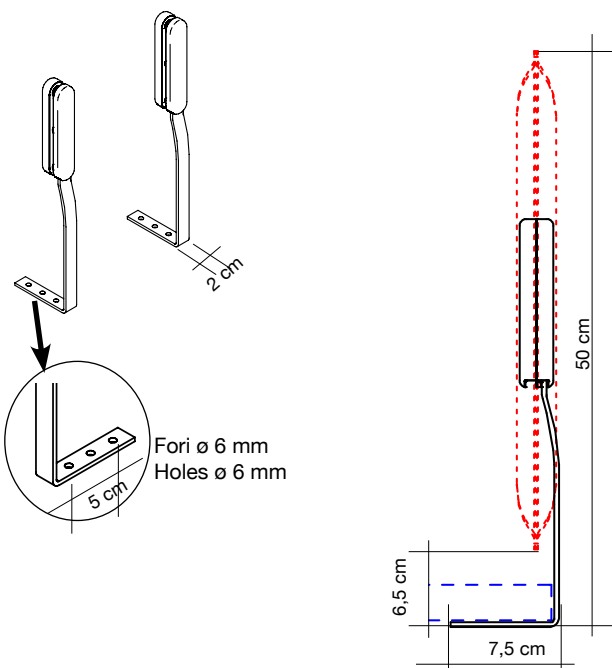
**7M515-GA**

Grigio argento
Silver grey
Gris argenté
Gris plata
Silbergrau

1 coppia / 1 pair
1 paire / 1 pare
1 Paar

7M515-BO

Bianco opaco
Mat white
Blanc mat
Blanco mate
Mattweiß

1 coppia / 1 pair
1 paire / 1 pare
1 Paar

Coppia staffe in acciaio verniciato con polveri epossidiche per fissaggio sotto il piano della scrivania tramite viti (non incluse). Attacchi al pannello Mitesco e coperture in tecnopolimero grigio o bianco. **Per pannelli Mitesco Desk pag. 20.**

Pair of brackets in powder-coated steel to be fixed under the desk top with screws (not included). Mitesco panel connections and front covers in grey or white high-tech polymer. **For Mitesco Desk panels page 20.**

Paire d'étriers en acier peint époxy pour fixation au dessous du le bureau par des vis (pas incluses). Jonctions au panneau Mitesco et couvertures en technopolymère gris ou blanc. **Pour panneaux Mitesco Desk page 20.**

Par de abrazaderas de acero recubierto epoxi para fijación debajo el plan del escritorio por medio de tornillos (no incluydos). Enganches al panel Mitesco y coberturas de polímero gris o blanco. **Para panels Mitesco Desk pag. 20.**

1 Paar Halterungen aus pulverbeschichtetem Stahl zur Befestigung unter der Tischplatte durch Schrauben (nicht inkludiert). Mitesco-Paneelbefestigungen und Abdeckungen aus grauem oder weissem Technopolymer. **Für Mitesco Desk Paneele, Seite 20.**

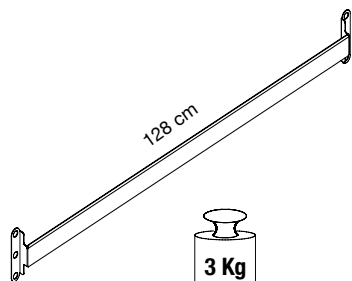

3 Kg
Portata massima
Maximum load

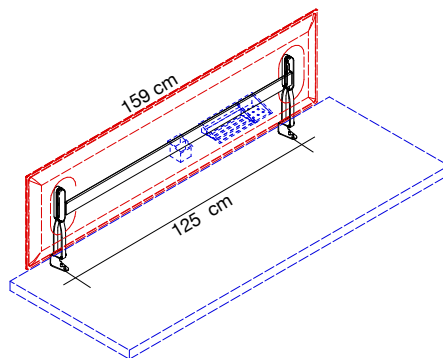

7M546-GA
Grigio argento
Silver grey
Gris argenté
Gris plata
Silbergrau

7M546-BO
Bianco opaco
Mat white
Blanc mat
Blanco mate
Mattweiß

Barra porta accessori Desk-Up realizzata in acciaio verniciato con polveri epossidiche.
Da utilizzare con staffe 7M5100-GA / 7M5100-BO / 7M515-GA / 7M515-BO

Epoxy powder-coated steel toolbar for Desk-Up accessories.
To be used with brackets 7M5100-GA / 7M5100-BO / 7M515-GA / 7M515-BO.

Profilé pour accessoires Desk-Up en acier peint en époxy.
Utiliser avec étriers 7M5100-GA / 7M5100-BO / 7M515-GA / 7M515-BO.

Perfil para accesorios Desk-Up realizado de acero recubierto epoxy.
Utilización con abrazaderas 7M5100-GA / 7M5100-BO / 7M515-GA / 7M515-BO.

Systemschiene aus pulverbeschichtetem Stahl für Desk-Up-Schalen. Zur Verwendung mit den Halterungen 7M5100-GA / 7M5100-BO / 7M515-GA / 7M515-BO.

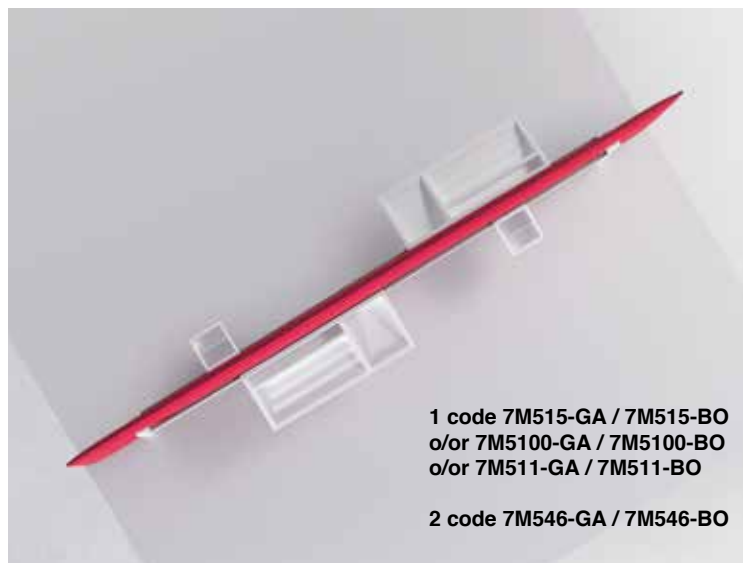

1 code 7M515-GA / 7M515-BO
o/or 7M5100-GA / 7M5100-BO
o/or 7M511-GA / 7M511-BO

2 code 7M546-GA / 7M546-BO

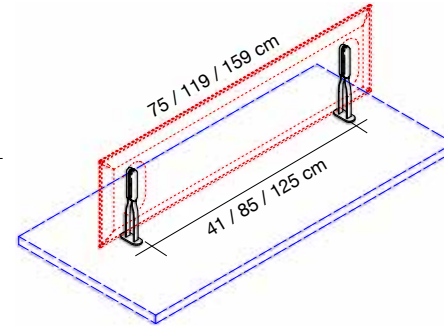
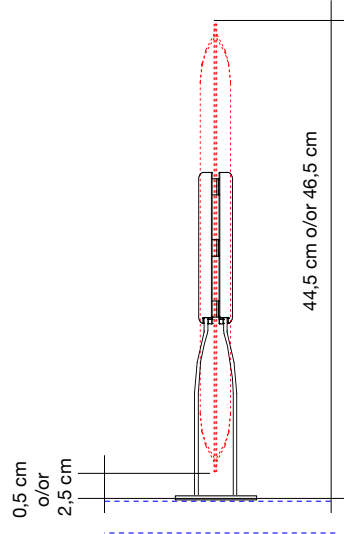
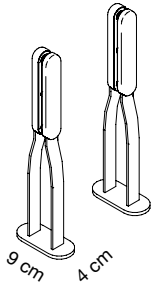
**7M517-GA**

Grigio argento
Silver grey
Gris argenté
Gris plata
Silbergrau

1 coppia / 1 pair
1 paire / 1 pare
1 Paar

7M517-BO

Bianco opaco
Mat white
Blanc mat
Blanco mate
Mattweiß

1 coppia / 1 pair
1 paire / 1 pare
1 Paar

Coppia staffe con base in acciaio verniciato con polveri epossidiche per fissaggio al piano della scrivania. Fissaggio al piano obbligatorio a cura del cliente. Scegliere il tipo di fissaggio / incollaggio idoneo alla superficie del piano. Attacchi al pannello Mitesco e coperture in tecnopolimero grigio o bianco. **Per pannelli Mitesco Desk pag. 20.**

Pair of brackets with base in powder coated steel for fixing to the desk top. Mandatory fastening to the top at customer's care. Choose the most suitable connection/gluing for the surface. Mitesco panel connections and front covers in grey or white high-tech polymer. **For Mitesco Desk panels p. 20.**

Paire d'étriers avec base en acier peint en époxy à fixer au dessus du bureau. Fixation au dessus obligatoire de la part du client. Choisir le type d'accrochage/collage adapté à la surface du dessus. Accrochages au panneau Mitesco et couvertures en technopolymère gris ou blanc. **Pour panneaux Mitesco Desk page 20.**

Par de abrazaderas con base de acero recubierto epoxi para fijación al plan del escritorio. Enganche al plano obligatorio por parte del cliente. Elegir el tipo de sujetador / enlace lo mas adecuado para la superficie del plano. Enganches al panel Mitesco y coberturas en polimero gris o blanco. **Para panels Mitesco Desk pag. 20.**

1 Paar Halterungen mit Standfüßen aus pulverbeschichtetem Stahl zur Befestigung auf der Tischplatte. Befestigung durch den Kunden unbedingt erforderlich. Wählen Sie die am besten geeignete Art der Verbindung/Verklebung für die betreffende Oberfläche. Mitesco-Paneelbefestigungen und Abdeckungen aus grauem oder weißem Technopolymer. **Für Mitesco Desk Paneele, Seite 20.**

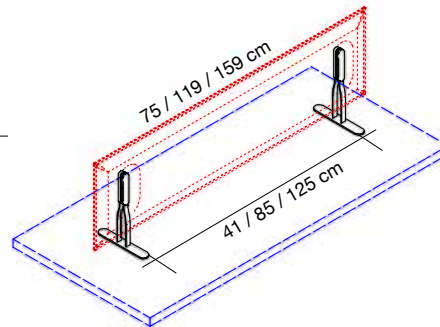
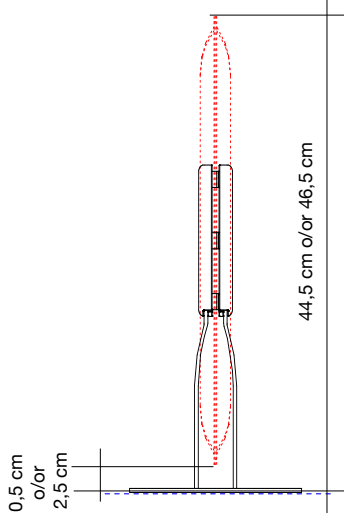
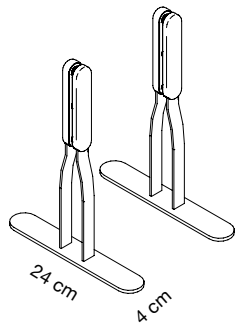
**7M519-GA**

Grigio argento
Silver grey
Gris argenté
Gris plata
Silbergrau

1 coppia / 1 pair
1 paire / 1 pare
1 Paar

7M519-BO

Bianco opaco
Mat white
Blanc mat
Blanco mate
Mattweiß

1 coppia / 1 pair
1 paire / 1 pare
1 Paar

Coppia staffe con base in acciaio verniciato con polveri epossidiche per appoggio al piano della scrivania. Attacchi al pannello Mitesco e coperture in tecnopolimero grigio o bianco. **Per pannelli Mitesco Desk pag. 20.**

Pair of brackets with base in powder coated steel for desk top stand. Mitesco panel connections and front covers in grey or white high-tech polymer. **For Mitesco Desk panels page 20.**

Paire d'étriers avec base en acier peint en époxy à poser sur le dessus du bureau. Accrochages au panneau Mitesco et couvertures en technopolymère gris ou blanc. **Pour panneaux Mitesco Desk page 20.**

Par de abrazaderas con base de acero recubierto epoxi para apoyar al escritorio. Enganches al panel Mitesco y coberturas en polimero gris o blanco. **Para panels Mitesco Desk pag. 20.**

Paar Halterungen mit Standfüßen aus pulverbeschichtetem Stahl zur Aufstellung auf der Tischplatte. Mitesco-Paneelbefestigungen und Abdeckungen aus grauem oder weißem Technopolymer. **Für Mitesco Desk Paneele, Seite 20.**

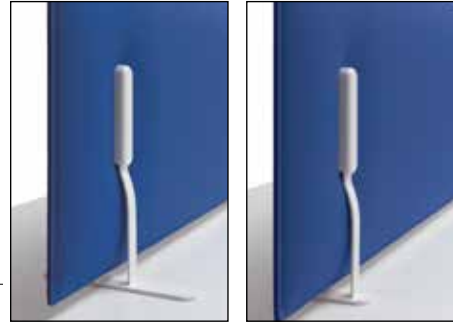
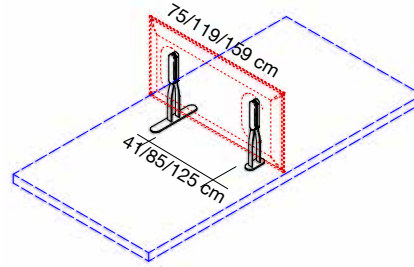
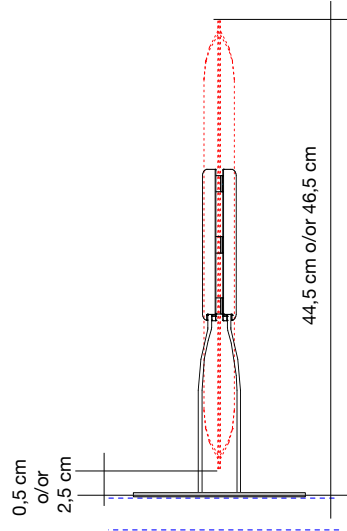
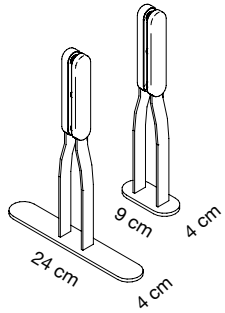

7M518-GA

Grigio argento
Silver grey
Gris argenté
Gris plata
Silbergrau

1 coppia / 1 pair
1 paire / 1 pare
1 Paar

7M518-BO

Bianco opaco
Mat white
Blanc mat
Blanco mate
Mattweiß

1 coppia / 1 pair
1 paire / 1 pare
1 Paar

Coppia staffe con base in acciaio verniciato con polveri epossidiche per appoggio al piano della scrivania.
Attacchi al pannello Mitesco e coperture in tecnopolimero grigio o bianco. **Per pannelli Mitesco Desk pag. 20.**

Pair of brackets with base in powder coated steel for desk top stand.

Mitesco panel connections and front covers in grey or white high-tech polymer. **For Mitesco Desk panels page 20.**

Paire d'étriers avec base en acier peint en époxy à poser sur le dessus du bureau.
Accrochages au panneau Mitesco et couvertures en technopolymère gris ou blanc. **Pour panneaux Mitesco Desk page 20.**

Par de embrazaderas con base de acero recubierto epoxi para apoyar al escritorio.
Enganches al panel Mitesco y coberturas en polímero gris o blanco. **Para panels Mitesco Desk pag. 20.**

Paar Halterungen mit Standfüßen aus pulverbeschichtetem Stahl zur Aufstellung auf der Tischplatte.
Mitesco-Panelbefestigungen und Abdeckungen aus grauem oder weißem Technopolymer. **Für Mitesco Desk Paneele, Seite 20.**

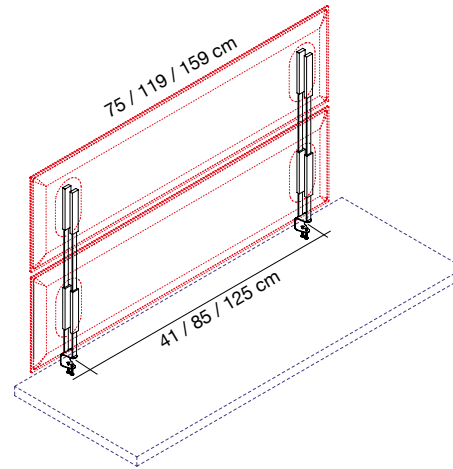
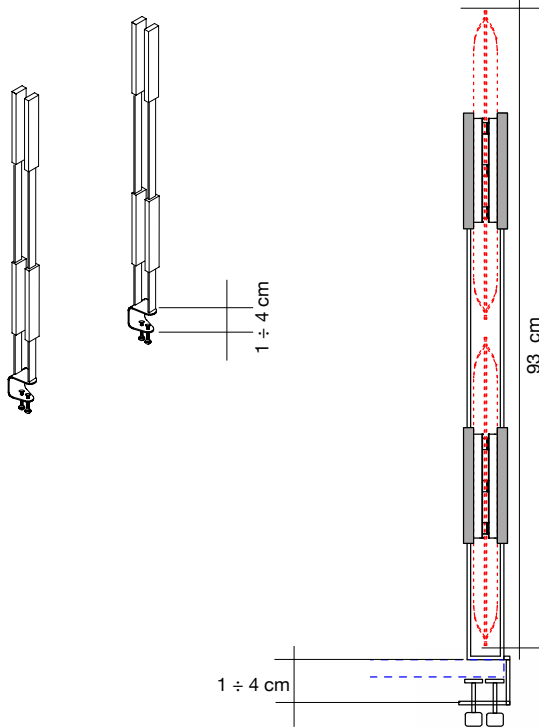

**7M520-GA**

Grigio argento
Silver grey
Gris argenté
Gris plata
Silbergrau

1 coppia / 1 pair
1 paire / 1 pare
1 Paar

7M520-BO

Bianco opaco
Mat white
Blanc mat
Blanco mate
Mattweiß

1 coppia / 1 pair
1 paire / 1 pare
1 Paar

Coppia staffe con morsetto in acciaio verniciato con polveri epossidiche per fissaggio al piano della scrivania.
Attacchi al pannello Mitesco e coperture in tecnopolimero grigio o bianco.

PER DUE PANNELLI Mitesco Desk pag. 20.

Pair of brackets with clamp in powder-coated steel for connection to the desk top.

Mitesco panel connections and front covers in grey or white high-tech polymer. **FOR TWO Mitesco Desk PANELS page 20.**

Paire d'étriers avec étai en acier peint époxy pour fixation au bureau. Jonctions au panneau Mitesco et couvertures en technopolymère gris ou blanc.

POUR DEUX PANNEAUX Mitesco Desk page 20.

Par de abrazaderas con sujetador en acero recubierto epoxi para fijación al plan del escritorio.

Enganches al panel Mitesco y coberturas de polímero gris o blanco.

PARA DOS PANELS Mitesco Desk pag. 20.

1 Paar Halterungen aus pulverbeschichtetem Stahl mit Klemmen zur Befestigung an der Tischplatte.

Mitesco-Panelbefestigungen und Abdeckungen aus grauem oder weissem Technopolymer.

FUR ZWEI Mitesco Desk PANELE, Seite 20.



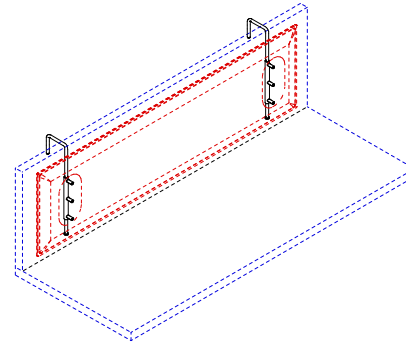
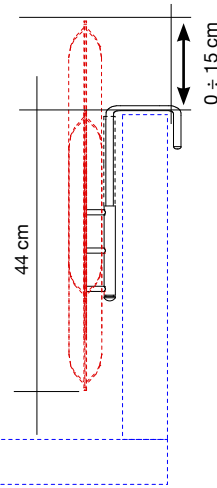
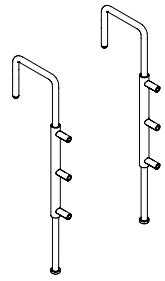

7M531-GA

Grigio argento
Silver grey
Gris argenté
Gris plata
Silbergrau

1 coppia / 1 pair
1 paire / 1 pare
1 Paar

Coppia attacchi regolabili in acciaio verniciato con polveri epossidiche per paretine già esistenti.
Non adatti per paretine in vetro e/o materiali fragili o poco resistenti.
Per pannelli Mitesco pag. 68/69.

Pair of adjustable brackets in powder coated steel for existing partitions. Not suitable for glass or fragile partitions.

For Mitesco panels page 68/69.

Paire d'accrochages réglables en acier peint en époxy pour cloisons déjà en place.
Ils ne sont pas adaptés aux cloisons en verre et/ou matériaux fragiles ou peu résistants.

Pour panneaux Mitesco page 68/69.

Par de embrazaderas regulables con base de acero recubierto epoxi para particiones ya existentes.

No adecuado para particiones en vidrio o materiales frágiles.

Para panel Mitesco. **Para panels Mitesco pag. 68/69.**

1 Paar verstellbare Befestigungen aus pulverbeschichtetem Stahl zur Aufhängung an Trennwänden.

Nicht geeignet für Trennwände aus Glas und/oder zerbrechlichen bzw. nicht widerstandsfähigen Materialien.

Für Mitesco Paneele, Seite 68/69.

Spessore massimo paretina 6 cm
Max. depth of the partition 6 cm

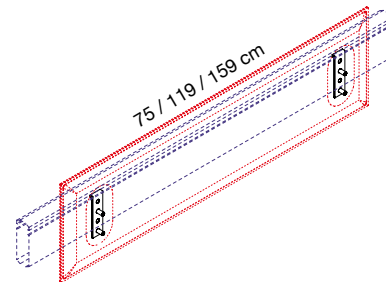
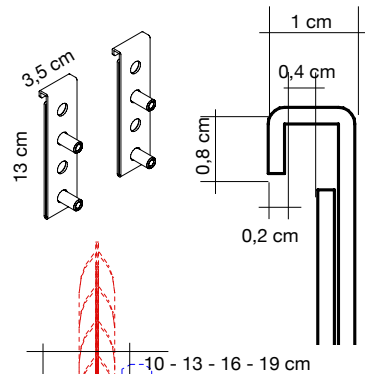
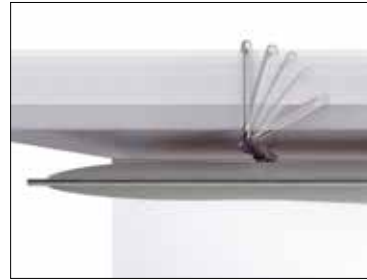
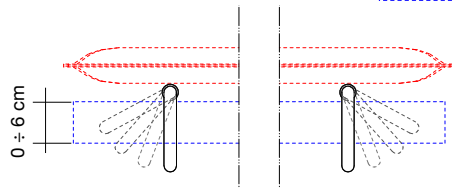

7M535-GA

Grigio argento
Silver grey
Gris argenté
Gris plata
Silbergrau

1 coppia / 1 pair
1 paire / 1 pare
1 Paar

Coppia agganci regolabili in acciaio verniciato con polveri epossidiche per profili (tipo Desk-Up). **Per pannelli Mitesco pag. 68/69.**

Pair of adjustable hooks in powder coated steel for profiles (Desk-Up kind). **For Mitesco panels pages 68/69.**

Paire d'accrochages réglables en acier peint en époxy pour profils (type Desk-Up). **Pour panneaux Mitesco page 68/69.**

Par de enganches regulables de acero recubierto epoxi para perfiles (tipo Desk-Up). Para panel Mitesco. **Para panels Mitesco pag. 68/69.**



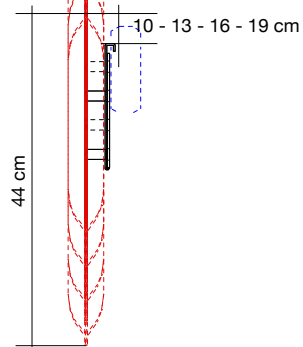

1 Paar verstellbare Haken aus pulverbeschichtetem Stahl zur Einhängung in Profile (wie z.B. Desk-Up).

Für Mitesco Paneele, Seite 68/69.

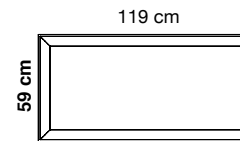
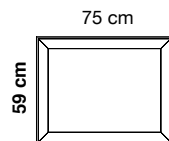
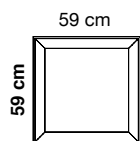

PER APPLICAZIONI A SCRIVANIA - DESK MOUNTING - MONTAGE SUR LE BUREAU
MONTAJE SOBRE MESAS DE ESCRITORIO - TISCHBEFESTIGUNG

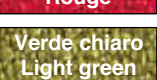

Colore Colour	Codice/Code Prezzo/Price	Codice/Code Prezzo/Price	Codice/Code Prezzo/Price	
 Bianco White Blanc	0001	7B0606-0001	7B0806-0001	7B1206-0001
 Grigio argento Silver grey Gris argenté	8004	7B0606-8004	7B0806-8004	7B1206-8004
 Grigio scuro Dark grey Gris foncé	8007	7B0606-8007	7B0806-8007	7B1206-8007
 Beige Beige Beige	1008	7B0606-1008	7B0806-1008	7B1206-1008
 Tortora Dove-grey Taupe	2005	7B0606-2005	7B0806-2005	7B1206-2005
 Giallo Yellow Jaune	3008	7B0606-3008	7B0806-3008	7B1206-3008
 Arancione Orange Orange	4030	7B0606-4030	7B0806-4030	7B1206-4030
 Rosso Red Rouge	4027	7B0606-4027	7B0806-4027	7B1206-4027
 Verde chiaro Light green Vert clair	7004	7B0606-7004	7B0806-7004	7B1206-7004
 Verde Green Vert	7013	7B0606-7013	7B0806-7013	7B1206-7013
 Blu Blue Bleu	6071	7B0606-6071	7B0806-6071	7B1206-6071
 Nero Black Noir	8033	7B0606-8033	7B0806-8033	7B1206-8033

Pannello con imbottitura interna in poliester a **densità variabile** Snowsound® Technology. Rivestimento esterno in tessuto di poliester Trevira CS®.

Panel with polyester internal padding with Snowsound® Technology **variable density**. Polyester covering in Trevira CS® fabric.

Panneau avec rembourrage interne en polyester à **densité variable** Snowsound® Technology. Revêtement externe en tissu de polyester Trevira CS®.

Panel con acolchado interior de poliéster de **densidad variable** Snowsound® Technology. Revestimiento exterior de tejido de poliéster Trevira CS®.

Paneel mit Polyester-Füllmaterial von **unterschiedlicher Dichte** Snowsound® Technology. Polyester-Bezug aus Trevira CS®-Material.

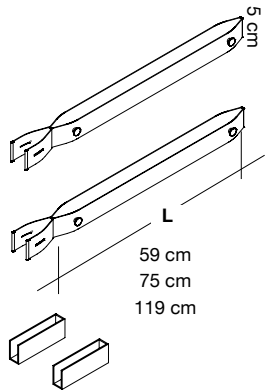

7BC306-GR

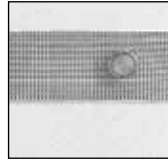

Per pannelli
For panels
L. 59 cm

Coppia cinghie elastiche in tecnopolimero per pannello Pli Desk complete di piedini antiscivolo. **Per pannelli Pli Desk pag. 28.**

Couple of hi-tech polymer elastic straps for Pli Desk panels complete with non-slip feet. **For Pli Desk panels page 28.**

7BC308-GR

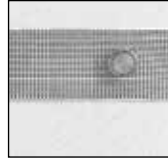

Per pannelli
For panels
L. 75 cm

Paire de sangles élastiques en technopolymère pour panneau Pli desk, vérins antidérapants inclus. **Pour panneaux Pli Desk page 28.**

Par de correas elásticas en tecnopolímero para panel Pli Desk completos con patas antideslizantes. **Para panels Pli Desk pag. 28.**

7BC312-GR

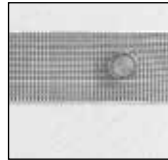

Per pannelli
For panels
L. 119 cm

Elastisches Riemen-Paar aus Technopolymer für das Paneel Pli Desk, das mit rutschfesten Füßchen ausgestattet ist. **Für Pli Desk Paneele, Seite 28.**

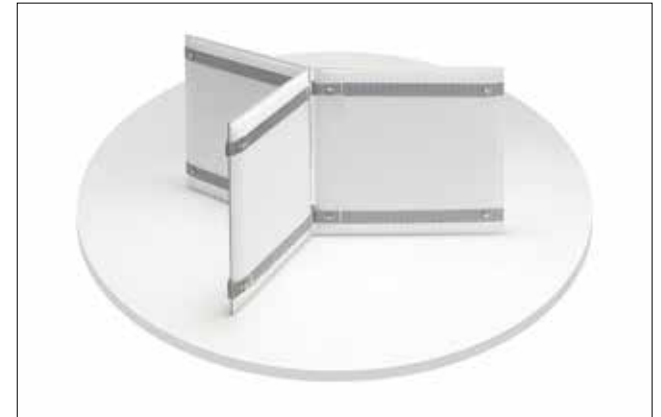

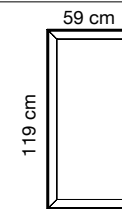
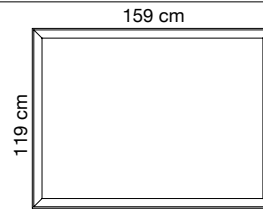
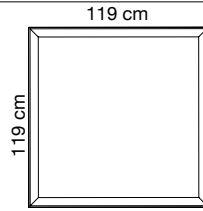

Colore Colour	Codice/Code Prezzo/Price	Codice/Code Prezzo/Price	Codice/Code Prezzo/Price
 Bianco White Blanc	0001	7S1212-0001	7S1216-0001
 Grigio argento Silver grey Gris argenté	8004	7S1212-8004	7S1216-8004
 Grigio scuro Dark grey Gris foncé	8007	7S1212-8007	7S1216-8007
 Beige Beige Beige	1008	7S1212-1008	7S1216-1008
 Tortora Dove-grey Taupe	2005	7S1212-2005	7S1216-2005
 Giallo Yellow Jaune	3008	7S1212-3008	7S1216-3008
 Arancione Orange Orange	4030	7S1212-4030	7S1216-4030
 Rosso Red Rouge	4027	7S1212-4027	7S1216-4027
 Verde chiaro Light green Vert clair	7004	7S1212-7004	7S1216-7004
 Verde Green Vert	7013	7S1212-7013	7S1216-7013
 Blu Blue Bleu	6071	7S1212-6071	7S1216-6071
 Nero Black Noir	8033	7S1212-8033	7S1216-8033

Pannello con imbottitura interna in poliester a **densità variabile** Snowsound® Technology. Rivestimento esterno in tessuto di poliester Trevira CS®.

Panel with polyester internal padding with Snowsound® Technology **variable density**. Polyester covering in Trevira CS® fabric.

Panneau avec rembourrage interne en polyester à **densité variable** Snowsound® Technology. Revêtement externe en tissu de polyester Trevira CS®.

Panel con acolchado interior de poliéster de **densidad variable** Snowsound® Technology. Revestimiento exterior de tejido de poliéster Trevira CS®.

Paneel mit Polyester-Füllmaterial von **unterschiedlicher Dichte** Snowsound® Technology. Polyester-Bezug aus Trevira CS®-Material.

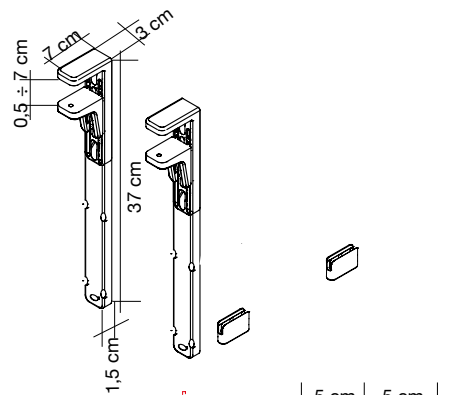

7S320-GA

Grigio argento
Silver grey
Gris argenté
Gris plata
Silbergrau

1 coppia / 1 pair
1 paire / 1 pare
1 Paar

Coppia attacchi con morsetto regolabile in alluminio e acciaio verniciato con polveri epossidiche per fissaggio al piano della scrivania. Completo di piedini in tecnopolimero e acciaio per l'appoggio a terra del pannello. **Per pannelli Oversize Desk pag. 30.**

Pair of brackets with adjustable clamp in powder-coated steel and aluminium for connection to the desk top. Complete with hi-tech polymer and steel small feet for the floor support of the panel. **For Oversize Desk panels page 30.**

Paire d'étriers avec étai réglable en acier et aluminium peint époxy pour fixation au bureau. Avec vérins en technopolymère et acier pour l'appui au sol du panneau. **Pour panneaux Oversize Desk page 30.**

Par de abrazaderas con sujetador ajustable en acero y aluminio recubierto epoxi para fijación al plan del escritorio. Completo con patas en tecnopolimero y acero para el apoyo en el suelo del panel. **Para panels Oversize Desk pag. 30.**

1 Paar Halterungen aus pulverbeschichtetem Stahl und Aluminium mit einstellbare Klemmen zur Befestigung an der Tischplatte. Mit Technopolymer- und Stahl-Füßchen ausgestattet, damit das Paneel auch auf den Boden gestellt werden kann. **Für Oversize Desk Paneele, Seite 30.**

7S320-BO

Bianco opaco
Mat white
Blanc mat
Blanco mate
Mattweiß

1 coppia / 1 pair
1 paire / 1 pare
1 Paar

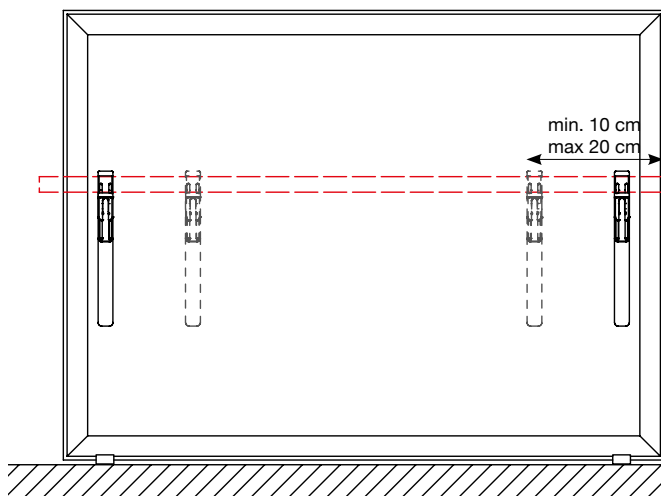
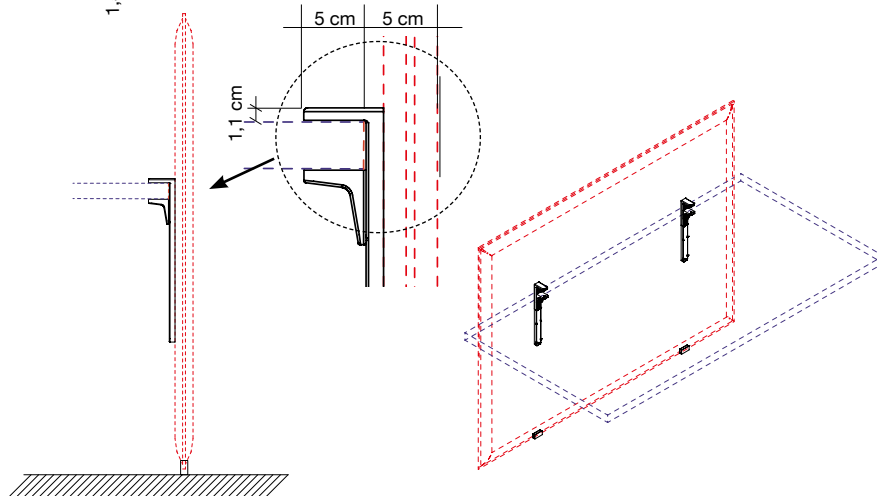

I morsetti possono essere applicati lungo il pannello.

The clamps can be positioned along the panel.

Les étriers peuvent être appliqués le long du panneau.

Los abrazaderas pueden ser posicionados a lo largo del panel.

Die Klemmen können beliebig entlang des Paneels angebracht werden.



PER APPLICAZIONI A SCRIVANIA - DESK MOUNTING - MONTAGE SUR LE BUREAU
MONTAJE SOBRE MESAS DE ESCRITORIO - TISCHBEFESTIGUNG

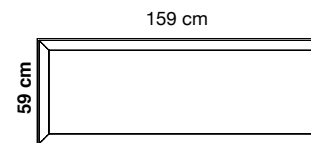
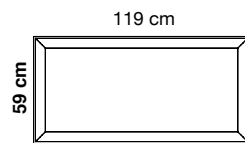
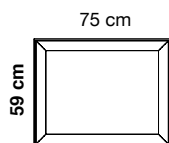

Colore Colour	Codice/Code Prezzo/Price	Codice/Code Prezzo/Price	Codice/Code Prezzo/Price	
Bianco White Blanc	0001	7S086-0001	7S126-0001	7S166-0001
Grigio argento Silver grey Gris argenté	8004	7S086-8004	7S126-8004	7S166-8004
Grigio scuro Dark grey Gris foncé	8007	7S086-8007	7S126-8007	7S166-8007
Beige Beige Beige	1008	7S086-1008	7S126-1008	7S166-1008
Tortora Dove-grey Taupe	2005	7S086-2005	7S126-2005	7S166-2005
Giallo Yellow Jaune	3008	7S086-3008	7S126-3008	7S166-3008
Arancione Orange Orange	4030	7S086-4030	7S126-4030	7S166-4030
Rosso Red Rouge	4027	7S086-4027	7S126-4027	7S166-4027
Verde chiaro Light green Vert clair	7004	7S086-7004	7S126-7004	7S166-7004
Verde Green Vert	7013	7S086-7013	7S126-7013	7S166-7013
Blu Blue Bleu	6071	7S086-6071	7S126-6071	7S166-6071
Nero Black Noir	8033	7S086-8033	7S126-8033	7S166-8033

Pannello con imbottitura interna in poliester e **densità variabile** Snowsound® Technology. Rivestimento esterno in tessuto di poliester Trevira CS®.

Panel with polyester internal padding with Snowsound® Technology **variable density**. Polyester covering in Trevira CS® fabric.

Panneau avec rembourrage interne en polyester à **densité variable** Snowsound® Technology. Revêtement externe en tissu de polyester Trevira CS®.

Panel con acolchado interior de poliéster de **densidad variable** Snowsound® Technology. Revestimiento exterior de tejido de poliéster Trevira CS®.

Panel mit Polyester-Füllmaterial von **unterschiedlicher Dichte** Snowsound® Technology. Polyester-Bezug aus Trevira CS®-Material.



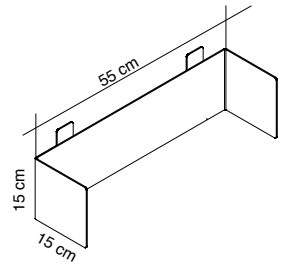

7S1055-MBO
Bianco opaco
Mat white
Blanc mat
Blanco mate
Mattweiß
L. 55 cm

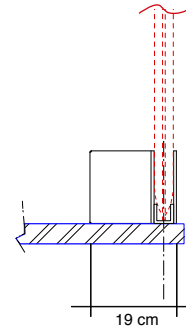

Struttura in acciaio verniciato con polveri epossidiche dotata di supporti per pannelli fonoassorbenti (**vedi pag. 32**). Predisposta per il fissaggio al piano scrivania. Completa di piedini antiscivolo per pannelli fonoassorbenti

Epoxy powder coated steel structure featuring supports designed for sound-absorbing panels (**see page 32**). Directly attachable to the desktop. Comprises antiskid feet for sound-absorbing panels.

Structure en acier peint en époxy avec supports pour panneaux phono-absorbants (**voir les pages 32**). Prédisposée pour la fixation au plateau du bureau. Vérins antidérapants pour panneaux phono-absorbants inclus.

Estructura en acero con epoxi, se incluyen soportes diseñados para los paneles fonoabsorbentes (**ver pag. 32**). Puede ser fijadas al tablero. Comprende patas antideslizantes para los paneles fonoabsorbentes.

Halterungen aus pulverbeschichtetem Stahl für Akustikpaneele (**siehe Seite 32**), direkt an der Tischplatte zu befestigen, inklusive rutschfesten Standfüßen für die Akustikpaneele.

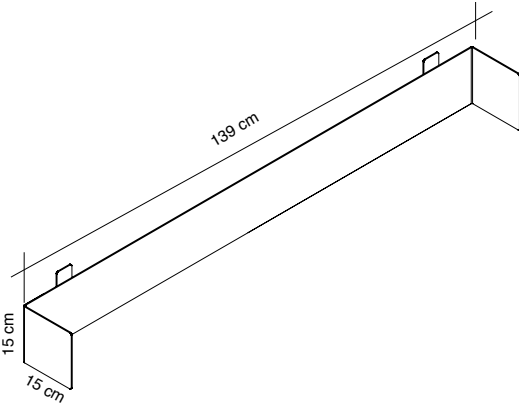

7S1140-MBO
Bianco opaco
Mat white
Blanc mat
Blanco mate
Mattweiß
L. 139 cm

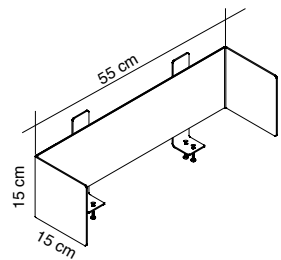
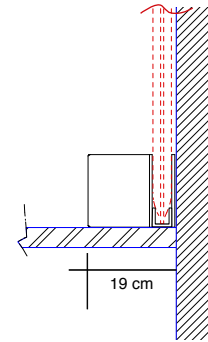

7S3055-BO
Bianco opaco
Mat white
Blanc mat
Blanco mate
Mattweiß
L. 55 cm

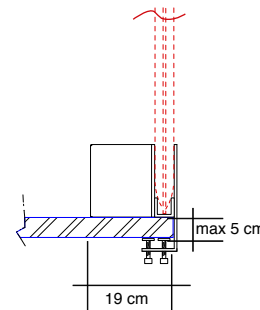

Struttura in acciaio verniciato con polveri epossidiche dotata di supporti per pannelli fonoassorbenti (**vedi pag. 32**). Dotata di morsetti per il fissaggio al piano scrivania. Completa di piedini antiscivolo per pannelli fonoassorbenti.

Epoxy powder coated steel structure featuring supports designed for sound-absorbing panels (**see page 32**). Adjustable clamps for desktop connection included. Comprises antiskid feet for sound-absorbing panels.

Structure en acier peint en époxy avec supports pour panneaux phono-absorbants (**voir les pages 32**). Avec étaux pour la fixation au plateau du bureau. Vérins antidérapants pour panneaux phono-absorbants inclus.

Estructura en acero con epoxi, se incluyen soportes diseñados para los paneles fonoabsorbentes (**ver pag. 32**). Incluidas mordazas ajustables para la conexión al tablero. Comprende patas antideslizantes para los paneles fonoabsorbentes.

Halterungen aus pulverbeschichtetem Stahl für Akustikpaneele (**siehe Seite 32**) mit verstellbaren Klemmen zur Befestigung an der Tischplatte, inklusive rutschfesten Standfüßen für die Akustikpaneele.

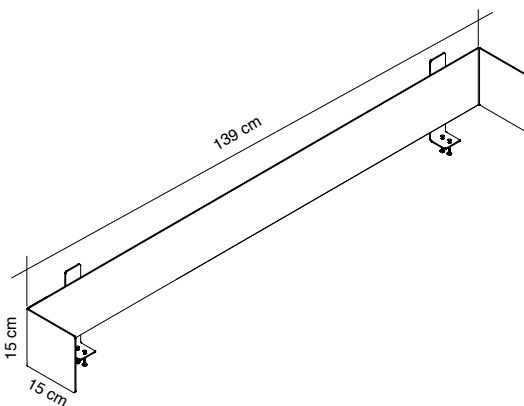

7S3140-BO
Bianco opaco
Mat white
Blanc mat
Blanco mate
Mattweiß
L. 139 cm

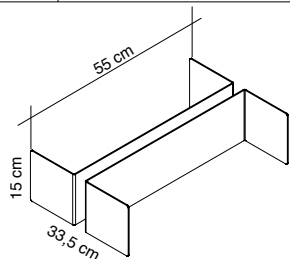

**7S2055-BBO**

Bianco opaco
Mat white
Blanc mat
Blanco mate
Mattweiß

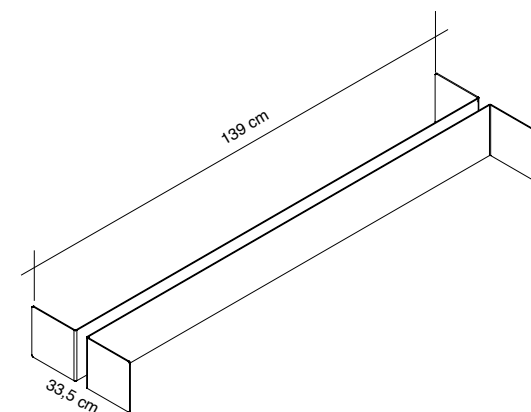
L. 55 cm**7S2140-BBO**

Bianco opaco
Mat white
Blanc mat
Blanco mate
Mattweiß

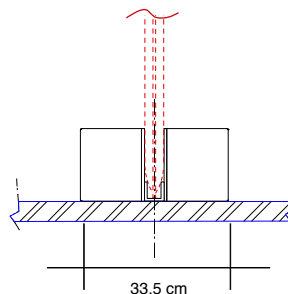
L. 139 cm

Struttura bifronte in acciaio verniciato con polveri epossidiche dotata di supporti per pannelli fonoassorbenti (**vedi pag. 32**). Predisposta per il fissaggio al piano scrivania. Completa di piedini antiscivolo per pannelli fonoassorbenti.

Epoxy powder coated two-faced steel structure featuring supports designed for sound-absorbing panels (**see page 32**). Directly attachable to the desktop. Comprises antiskid feet for sound-absorbing panels.

Structure double-face en acier peint en époxy avec supports pour panneaux phono-absorbants (**voir les pages 32**). Prédisposée pour la fixation au plateau du bureau. Vérins antidérapants pour panneaux phono-absorbants inclus.

Estructura en acero a doble cara con epoxi, se incluyen soportes diseñados para los paneles fonoabsorbentes (**ver pag. 32**). Puede ser fijadas al tablero. Comprende patas antideslizantes para los paneles fonoabsorbentes.

Doppelseitige Halterungen aus pulverbeschichtetem Stahl für Akustikpaneele (**siehe Seite 32**), direkt an der Tischplatte zu befestigen, inklusive rutschfesten Standfüßen für die Akustikpaneele.

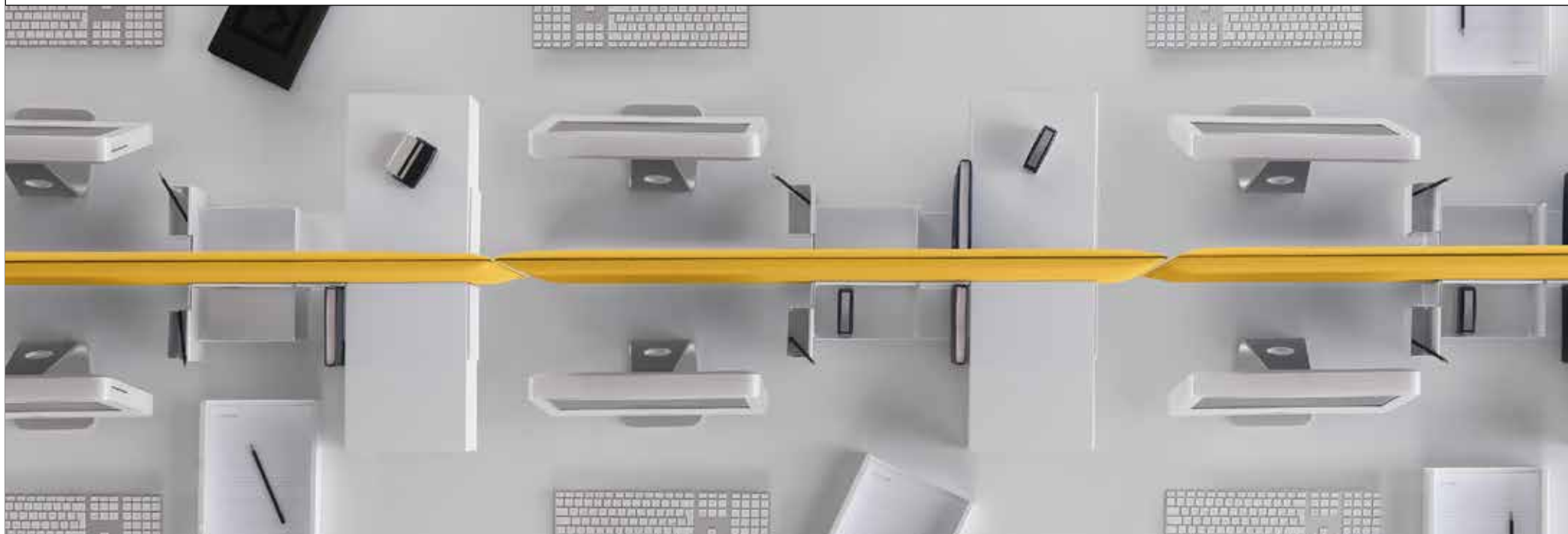

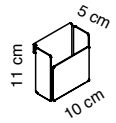

7S41-BO
Bianco opaco
Mat white
Blanc mat
Blanco mate
Mattweiß

Portamatite in acciaio verniciato con polveri epossidiche.

Powder coated steel pen holder.

Pot à crayons en acier peint epoxy.

Portalapiceros en acero recubierto.

Bleistiftköcher aus pulverbeschichtetem Stahl.

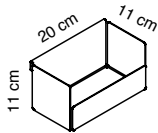

7S42-BO
Bianco opaco
Mat white
Blanc mat
Blanco mate
Mattweiß

Portaoggetti in acciaio verniciato con polveri epossidiche.

Powder coated steel object holder.

Porte objects en acier peint epoxy.

Portaobjectos en acero recubierto.

Objektablage aus pulverbeschichtetem Stahl.

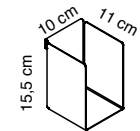

7S43-BO
Bianco opaco
Mat white
Blanc mat
Blanco mate
Mattweiß

Reggilibri in acciaio verniciato con polveri epossidiche.

Powder coated steel book holder.

Serre-livres en acier peint epoxy.

Sujetalibros en acero recubierto.

Buchstütze aus pulverbeschichtetem Stahl.

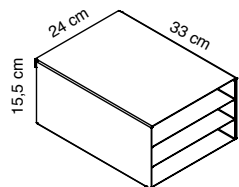

7S44-BO
Bianco opaco
Mat white
Blanc mat
Blanco mate
Mattweiß

3 vaschette estraibili in acciaio verniciato con polveri epossidiche.

3 epoxy powder coated extractable steel trays.

3 bacs extractibles en acier peint en époxy.

3 bandejas extraíbles en acero epoxi.

3 ausziehbare Ablagefächer aus pulverbeschichtetem Stahl.

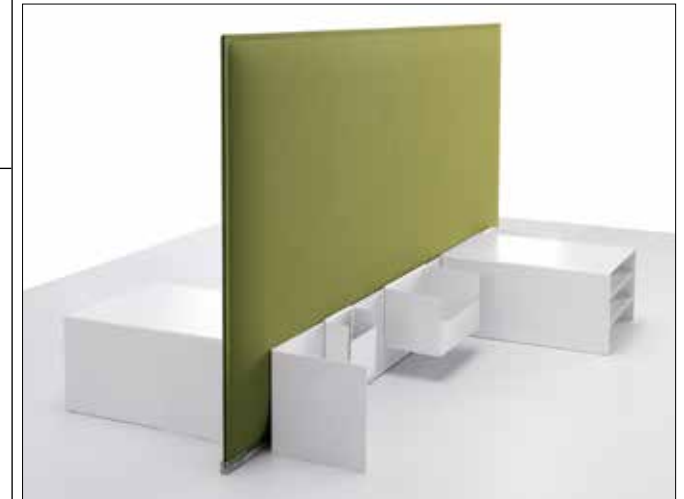

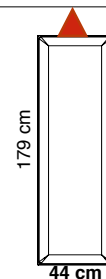
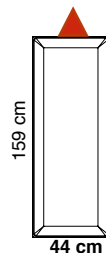
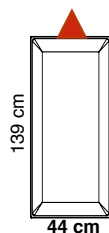
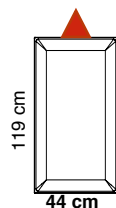
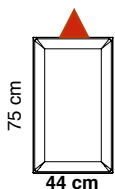

Colore Colour	Codice/Code Prezzo/Price	Codice/Code Prezzo/Price	Codice/Code Prezzo/Price	Codice/Code Prezzo/Price	Codice/Code Prezzo/Price	
Bianco White Blanc	0001	7S408-0001	7S412-0001	7S414-0001	7S416-0001	7S418-0001
Grigio argento Silver grey Gris argenté	8004	7S408-8004	7S412-8004	7S414-8004	7S416-8004	7S418-8004
Grigio scuro Dark grey Gris foncé	8007	7S408-8007	7S412-8007	7S414-8007	7S416-8007	7S418-8007
Beige Beige Beige	1008	7S408-1008	7S412-1008	7S414-1008	7S416-1008	7S418-1008
Tortora Dove-grey Taupe	2005	7S408-2005	7S412-2005	7S414-2005	7S416-2005	7S418-2005
Giallo Yellow Jaune	3008	7S408-3008	7S412-3008	7S414-3008	7S416-3008	7S418-3008
Arancione Orange Orange	4030	7S408-4030	7S412-4030	7S414-4030	7S416-4030	7S418-4030
Rosso Red Rouge	4027	7S408-4027	7S412-4027	7S414-4027	7S416-4027	7S418-4027
Verde chiaro Light green Vert clair	7004	7S408-7004	7S412-7004	7S414-7004	7S416-7004	7S418-7004
Verde Green Vert	7013	7S408-7013	7S412-7013	7S414-7013	7S416-7013	7S418-7013
Blu Blue Bleu	6071	7S408-6071	7S412-6071	7S414-6071	7S416-6071	7S418-6071
Nero Black Noir	8033	7S408-8033	7S412-8033	7S414-8033	7S416-8033	7S418-8033



ATTENZIONE: attacchi non compresi. Vedi pag. 41

WARNING: fixings not included. See page 41

ATTENTION: fixations pas incluses. Voir à la page 41

ADVERTENCIA: fijaciones no incluidas. Ver página 41

ACHTUNG: Befestigungen nicht enthalten. Sehen Sie an der Seite 41

Pannello con imbottitura interna in poliester a **densità variabile** Snowsound® Technology. Rivestimento esterno in tessuto di poliester Trevira CS®.

Panel with polyester internal padding with Snowsound® Technology **variable density**. Polyester covering in Trevira CS® fabric.

Panneau avec rembourrage interne en polyester à **densité variable** Snowsound® Technology. Revêtement externe en tissu de polyester Trevira CS®.

Panel con acolchado interior de poliéster de **densidad variable** Snowsound® Technology. Revestimiento exterior de tejido de poliéster Trevira CS®.

Paneel mit Polyester-Füllmaterial von **unterschiedlicher Dichte** Snowsound® Technology. Polyester-Bezug aus Trevira CS®-Material.

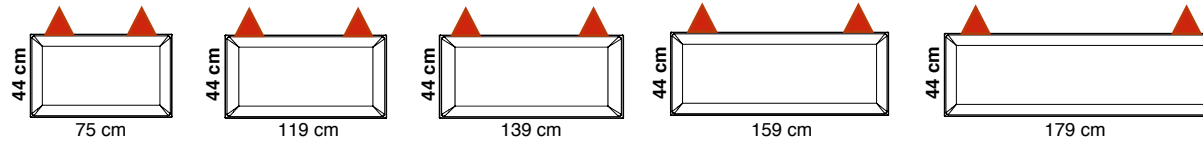

Colore Colour	Codice/Code Prezzo/Price	Codice/Code Prezzo/Price	Codice/Code Prezzo/Price	Codice/Code Prezzo/Price	Codice/Code Prezzo/Price	
Bianco White Blanc	0001	7S408-0001	7S412-0001	7S414-0001	7S416-0001	7S418-0001
Grigio argento Silver grey Gris argenté	8004	7S408-8004	7S412-8004	7S414-8004	7S416-8004	7S418-8004
Grigio scuro Dark grey Gris foncé	8007	7S408-8007	7S412-8007	7S414-8007	7S416-8007	7S418-8007
Beige Beige Beige	1008	7S408-1008	7S412-1008	7S414-1008	7S416-1008	7S418-1008
Tortora Dove-grey Taupe	2005	7S408-2005	7S412-2005	7S414-2005	7S416-2005	7S418-2005
Giallo Yellow Jaune	3008	7S408-3008	7S412-3008	7S414-3008	7S416-3008	7S418-3008
Arancione Orange Orange	4030	7S408-4030	7S412-4030	7S414-4030	7S416-4030	7S418-4030
Rosso Red Rouge	4027	7S408-4027	7S412-4027	7S414-4027	7S416-4027	7S418-4027
Verde chiaro Light green Vert clair	7004	7S408-7004	7S412-7004	7S414-7004	7S416-7004	7S418-7004
Verde Green Vert	7013	7S408-7013	7S412-7013	7S414-7013	7S416-7013	7S418-7013
Blu Blue Bleu	6071	7S408-6071	7S412-6071	7S414-6071	7S416-6071	7S418-6071
Nero Black Noir	8033	7S408-8033	7S412-8033	7S414-8033	7S416-8033	7S418-8033



ATTENZIONE: attacchi non compresi. Vedi pag. 41

WARNING: fixings not included. See page 41

ATTENTION: fixations pas incluses. Voir à la page 41

ADVERTENCIA: fijaciones no incluidas. Ver página 41

ACHTUNG: Befestigungen nicht enthalten. Sehen Sie an der Seite 41

Pannello con imbottitura interna in poliester a **densità variabile** Snowsound® Technology. Rivestimento esterno in tessuto di poliester Trevira CS®.

Panel with polyester internal padding with Snowsound® Technology **variable density**. Polyester covering in Trevira CS® fabric.

Panneau avec rembourrage interne en polyester à **densité variable** Snowsound® Technology. Revêtement externe en tissu de polyester Trevira CS®.

Panel con acolchado interior de poliéster de **densidad variable** Snowsound® Technology. Revestimiento exterior de tejido de poliéster Trevira CS®.

Paneel mit Polyester-Füllmaterial von **unterschiedlicher Dichte** Snowsound® Technology. Polyester-Bezug aus Trevira CS®-Material.

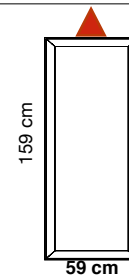
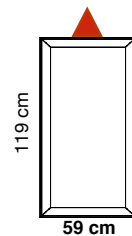
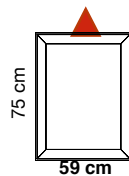
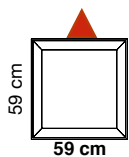

Colore Colour	Codice/Code Prezzo/Price	Codice/Code Prezzo/Price	Codice/Code Prezzo/Price	Codice/Code Prezzo/Price	
Bianco White Blanc	0001	7S066-0001	7S086-0001	7S126-0001	7S166-0001
Grigio argento Silver grey Gris argenté	8004	7S066-8004	7S086-8004	7S126-8004	7S166-8004
Grigio scuro Dark grey Gris foncé	8007	7S066-8007	7S086-8007	7S126-8007	7S166-8007
Beige Beige Beige	1008	7S066-1008	7S086-1008	7S126-1008	7S166-1008
Tortora Dove-grey Taupe	2005	7S066-2005	7S086-2005	7S126-2005	7S166-2005
Giallo Yellow Jaune	3008	7S066-3008	7S086-3008	7S126-3008	7S166-3008
Arancione Orange Orange	4030	7S066-4030	7S086-4030	7S126-4030	7S166-4030
Rosso Red Rouge	4027	7S066-4027	7S086-4027	7S126-4027	7S166-4027
Verde chiaro Light green Vert clair	7004	7S066-7004	7S086-7004	7S126-7004	7S166-7004
Verde Green Vert	7013	7S066-7013	7S086-7013	7S126-7013	7S166-7013
Blu Blue Bleu	6071	7S066-6071	7S086-6071	7S126-6071	7S166-6071
Nero Black Noir	8033	7S066-8033	7S086-8033	7S126-8033	7S166-8033



ATTENZIONE: attacchi non compresi. Vedi pag. 41

WARNING: fixings not included. See page 41

ATTENTION: fixations pas incluses. Voir à la page 41

ADVERTENCIA: fijaciones no incluidas. Ver página 41

ACHTUNG: Befestigungen nicht enthalten. Sehen Sie an der Seite 41

Pannello con imbottitura interna in poliester a **densità variabile** Snowsound® Technology. Rivestimento esterno in tessuto di poliester Trevira CS®.

Panel with polyester internal padding with Snowsound® Technology **variable density**. Polyester covering in Trevira CS® fabric.

Panneau avec rembourrage interne en polyester à **densité variable** Snowsound® Technology. Revêtement externe en tissu de polyester Trevira CS®.

Panel con acolchado interior de poliéster de **densidad variable** Snowsound® Technology. Revestimiento exterior de tejido de poliéster Trevira CS®.

Paneel mit Polyester-Füllmaterial von **unterschiedlicher Dichte** Snowsound® Technology. Polyester-Bezug aus Trevira CS®-Material.

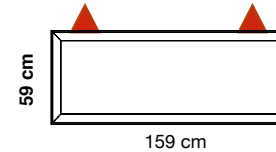
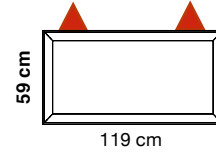
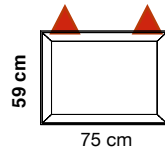

Colore Colour	Codice/Code Prezzo/Price	Codice/Code Prezzo/Price	Codice/Code Prezzo/Price	
Bianco White Blanc	0001	7S086-0001	7S126-0001	7S166-0001
Grigio argento Silver grey Gris argenté	8004	7S086-8004	7S126-8004	7S166-8004
Grigio scuro Dark grey Gris foncé	8007	7S086-8007	7S126-8007	7S166-8007
Beige Beige Beige	1008	7S086-1008	7S126-1008	7S166-1008
Tortora Dove-grey Taupe	2005	7S086-2005	7S126-2005	7S166-2005
Giallo Yellow Jaune	3008	7S086-3008	7S126-3008	7S166-3008
Arancione Orange Orange	4030	7S086-4030	7S126-4030	7S166-4030
Rosso Red Rouge	4027	7S086-4027	7S126-4027	7S166-4027
Verde chiaro Light green Vert clair	7004	7S086-7004	7S126-7004	7S166-7004
Verde Green Vert	7013	7S086-7013	7S126-7013	7S166-7013
Blu Blue Bleu	6071	7S086-6071	7S126-6071	7S166-6071
Nero Black Noir	8033	7S086-8033	7S126-8033	7S166-8033



ATTENZIONE: attacchi non compresi. Vedi pag. 41

WARNING: fixings not included. See page 41

ATTENTION: fixations pas incluses. Voir à la page 41

ADVERTENCIA: fijaciones no incluidas. Ver página 41

ACHTUNG: Befestigungen nicht enthalten. Sehen Sie an der Seite 41

Pannello con imbottitura interna in poliester a **densità variabile** Snowsound® Technology. Rivestimento esterno in tessuto di poliester Trevira CS®.

Panel with polyester internal padding with Snowsound® Technology **variable density**. Polyester covering in Trevira CS® fabric.

Panneau avec rembourrage interne en polyester à **densité variable** Snowsound® Technology. Revêtement externe en tissu de polyester Trevira CS®.

Panel con acolchado interior de poliéster de **densidad variable** Snowsound® Technology. Revestimiento exterior de tejido de poliéster Trevira CS®.

Paneel mit Polyester-Füllmaterial von **unterschiedlicher Dichte** Snowsound® Technology. Polyester-Bezug aus Trevira CS®-Material.

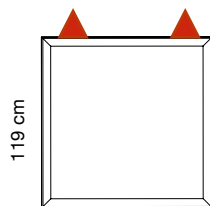

119 cm

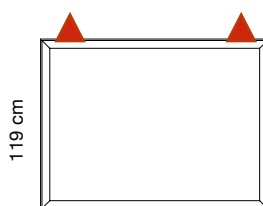

119 cm

159 cm

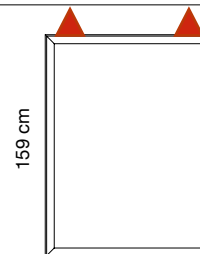

159 cm

119 cm

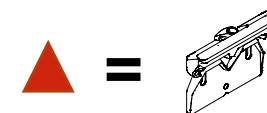

Colore Colour	Codice/Code Prezzo/Price	Codice/Code Prezzo/Price	Codice/Code Prezzo/Price
Bianco White Blanc	0001	7S1212-0001	7S1216-0001
Grigio argento Silver grey Gris argenté	8004	7S1212-8004	7S1216-8004
Grigio scuro Dark grey Gris foncé	8007	7S1212-8007	7S1216-8007
Beige Beige Beige	1008	7S1212-1008	7S1216-1008
Tortora Dove-grey Taupe	2005	7S1212-2005	7S1216-2005
Giallo Yellow Jaune	3008	7S1212-3008	7S1216-3008
Arancione Orange Orange	4030	7S1212-4030	7S1216-4030
Rosso Red Rouge	4027	7S1212-4027	7S1216-4027
Verde chiaro Light green Vert clair	7004	7S1212-7004	7S1216-7004
Verde Green Vert	7013	7S1212-7013	7S1216-7013
Blu Blue Bleu	6071	7S1212-6071	7S1216-6071
Nero Black Noir	8033	7S1212-8033	7S1216-8033

ATTENZIONE: attacchi non compresi. Vedi pag. 41**WARNING:** fixings not included. See page 41**ATTENTION:** fixations pas incluses. Voir à la page 41**ADVERTENCIA:** fijaciones no incluidas. Ver página 41**ACHTUNG:** Befestigungen nicht enthalten. Sehen Sie an der Seite 41

Pannello con imbottitura interna in poliester a **densità variabile** Snowsound® Technology. Rivestimento esterno in tessuto di poliester Trevira CS®.

Panel with polyester internal padding with Snowsound® Technology **variable density**. Polyester covering in Trevira CS® fabric.

Panneau avec rembourrage interne en polyester à **densité variable** Snowsound® Technology. Revêtement externe en tissu de polyester Trevira CS®.

Panel con acolchado interior de poliéster de **densidad variable** Snowsound® Technology. Revestimiento exterior de tejido de poliéster Trevira CS®.

Paneel mit Polyester-Füllmaterial von **unterschiedlicher Dichte** Snowsound® Technology. Polyester-Bezug aus Trevira CS®-Material.

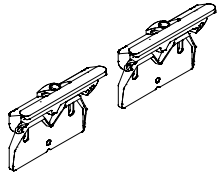

7S370-BO

Bianco opaco
Mat white
Blanc mat
Blanco mate
Mattweiß

1 coppia / 1 pair
1 paire / 1 pare
1 Paar

Coppia attacchi a parete in zama verniciata o nichel satinata.

Pair of wall fixings in zamac, painted or nickel satinated

Paire de fixations murales en zamak peinte ou nickel satinée.

7S370-C

Nichel satinato
Nickel satinéd
Nickel satinée
Niquel satinado
Nickel satiniert

1 coppia / 1 pair
1 paire / 1 pare
1 Paar

Set de fijaciones a pared en zamac, pintado o niquel satinado.

1 Paar Wandbefestigungen aus Zamak, beschichtet oder Nickel satiniert

ATTENZIONE: il simbolo ▲ riportato sui pannelli di pag. 36-37-38-39-40 indica il numero di attacchi necessari per il corretto fissaggio parete (attenzione: gli attacchi sono venduti a coppie)

WARNING: the symbol ▲ as depicted on the panels (pages 36-37-38-39-40) indicates the required number of connections for the correct wall fixing (warning: fixings are sold in pairs)

ATTENTION: le symbole ▲ sur les panneaux aux pages 36-37-38-39-40 indique la quantité de joints nécessaires pour une correcte fixation au mur (attention: les joints sont vendus en paire)

Advertencia: el símbolo ▲ representado en los paneles pag 36-37-38-39-40 indica el número necesario de conexiones para su correcta fijación a pared (se venden en set de 2 pzs)

ACHTUNG: das auf den Paneelen abgebildete Symbol ▲ (Seiten 36-37-38-39-40) bezeichnet die erforderliche Anzahl von Halterungen für die korrekte Wandmontage (Achtung: die Wandbefestigungen sind nur paarweise erhältlich)



Nichel satinato - Nickel satinéd - Nickel satinée - Niquel satinado
Nickel satiniert

Bianco opaco - Mat white - Blanc mat - Blanco mate - Mattweiß



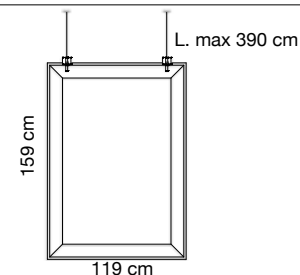
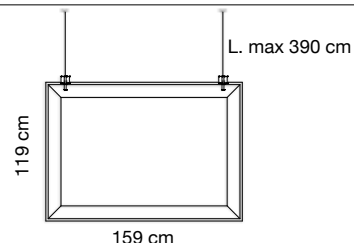
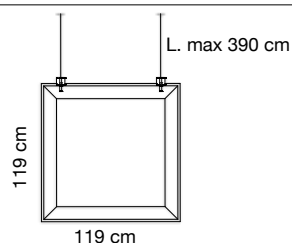
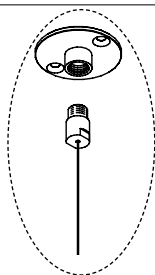

Colore Colour	Codice/Code Prezzo/Price	Codice/Code Prezzo/Price	Codice/Code Prezzo/Price
Bianco White Blanc	0001	7BOF1212-0001	7BOF1216-0001
Grigio argento Silver grey Gris argenté	8004	7BOF1212-8004	7BOF1216-8004
Grigio scuro Dark grey Gris foncé	8007	7BOF1212-8007	7BOF1216-8007
Beige Beige Beige	1008	7BOF1212-1008	7BOF1216-1008
Tortora Dove-grey Taupe	2005	7BOF1212-2005	7BOF1216-2005
Giallo Yellow Jaune	3008	7BOF1212-3008	7BOF1216-3008
Arancione Orange Orange	4030	7BOF1212-4030	7BOF1216-4030
Rosso Red Rouge	4027	7BOF1212-4027	7BOF1216-4027
Verde chiaro Light green Vert clair	7004	7BOF1212-7004	7BOF1216-7004
Verde Green Vert	7013	7BOF1212-7013	7BOF1216-7013
Blu Blue Bleu	6071	7BOF1212-6071	7BOF1216-6071
Nero Black Noir	8033	7BOF1212-8033	7BOF1216-8033

Pannello con imbottitura interna in poliester a **densità variabile** Snowsound® Technology. Rivestimento esterno in tessuto di poliester Trevira CS®. Completo di 2 supporti realizzati in pressofusione di metallo cromato che nascondono al loro interno il meccanismo di regolazione dei cavi di fissaggio a soffitto + 2 piastre in acciaio + 2 piastre a soffitto a 2 fori

Panel with polyester internal padding with Snowsound® Technology **variable density**. Polyester covering in Trevira CS® fabric. Complete with 2 supports made of die-cast chrome-plated metal that hide inside the adjustment mechanism of the ceiling fixing cables + 2 ceiling plates with 2 holes, 2 steel cables.

Panneau avec rembourrage interne en polyester à **densité variable** Snowsound® Technology. Revêtement externe en tissu de polyester Trevira CS®. Fourni avec 2 supports en métal chromé moulé sous pression qui cachent le mécanisme de réglage des câbles de fixation au plafond + 2 platines pour plafond à 2 trous -2 câbles en acier.

Panel con acolchado interior de poliéster de **densidad variable** Snowsound® Technology. Revestimiento exterior de tejido de poliéster Trevira CS®. Se completa con 2 soportes de metal fundido cromado que llevan dentro, escondido, el mecanismo de ajuste de los cables de fijación al techo + 2 cables de acero + 2 placas de techo con 2 huecos

Panel mit Polyester-Füllmaterial von **unterschiedlicher Dichte** Snowsound® Technology. Polyester-Bezug aus Trevira CS®-Material. Kit aus zwei im Druckgussverfahren hergestellten Lagern aus verchromtem Metall, die das System zur Regelung der Deckenaufhängungskabel verstecken + 2 Stahlseile + 2 Deckenmontageplatten mit 2 Befestigungsbohrungen

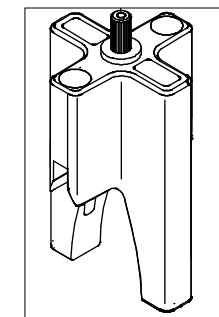

Dettaglio attacco
Support detail





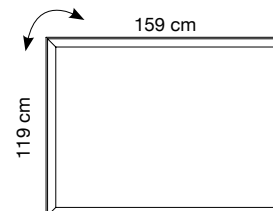
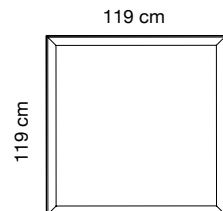

Colore Colour	Codice/Code Prezzo/Price	Codice/Code Prezzo/Price
Bianco White Blanc	0001	701212-0001
Grigio argento Silver grey Gris argenté	8004	701212-8004
Grigio scuro Dark grey Gris foncé	8007	701212-8007
Beige Beige Beige	1008	701212-1008
Tortora Dove-grey Taupe	2005	701212-2005
Giallo Yellow Jaune	3008	701212-3008
Arancione Orange Orange	4030	701212-4030
Rosso Red Rouge	4027	701212-4027
Verde chiaro Light green Vert clair	7004	701212-7004
Verde Green Vert	7013	701212-7013
Blu Blue Bleu	6071	701212-6071
Nero Black Noir	8033	701212-8033

Pannelli con imbottitura interna in poliester a **densità variabile** Snowsound® Technology. Rivestimento esterno in tessuto di poliester Trevira CS®. Completi di struttura posteriore in acciaio zincato e piastra in acciaio zincato per fissaggio a parete.

Panel with polyester internal padding with Snowsound® Technology **variable density**. Polyester covering in Trevira CS® fabric. Complete with galvanized steel back structure and steel plate for wall mounting.

Panneau avec rembourrage interne en polyester à **densité variable** Snowsound® Technology. Revêtement externe en tissu de polyester Trevira CS®. Avec structure postérieure en acier zingué et platine en acier zingué pour la fixation au mur.

Panel con acolchado interior de poliéster de **densidad variable** Snowsound® Technology. Revestimiento exterior en tejido de poliéster Trevira CS®.

Completo con estructura de respaldo de acero galvanizado y chapa de acero galvanizado para montaje en pared.

Panel mit Polyester-Füllmaterial von **unterschiedlicher Dichte** Snowsound® Technology. Polyester-Bezug aus Trevira CS®-Material. Mit Rückstruktur aus verzinktem Stahl und verzinkter Stahlplatte ausgestattet zur Befestigung an der Wand.

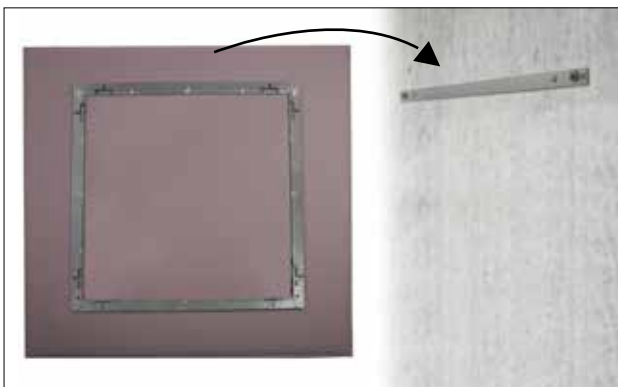
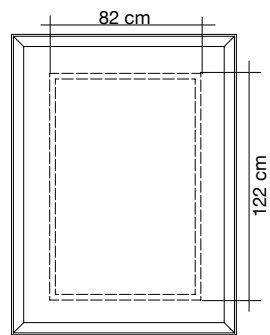
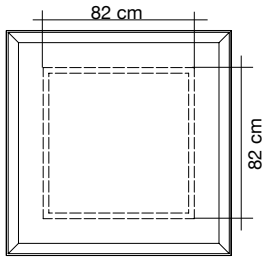

OVERSIZE CEILING

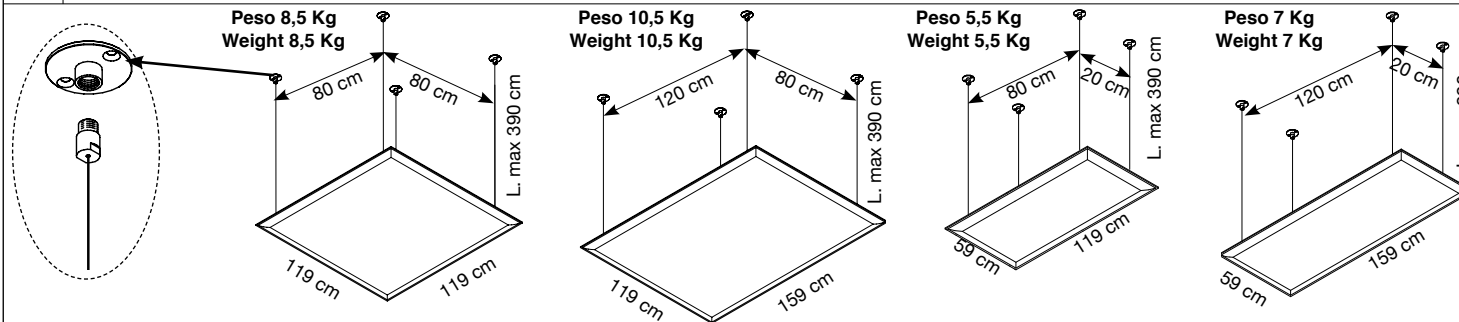

Colore Colour	Codice/Code Prezzo/Price	Codice/Code Prezzo/Price	Codice/Code Prezzo/Price	Codice/Code Prezzo/Price	
Bianco White Blanc	0001	7OF1212-0001	7OF1216-0001	7OF1206-0001	7OF1606-0001
Grigio argento Silver grey Gris argenté	8004	7OF1212-8004	7OF1216-8004	7OF1206-8004	7OF1606-8004
Grigio scuro Dark grey Gris foncé	8007	7OF1212-8007	7OF1216-8007	7OF1206-8007	7OF1606-8007
Beige Beige Beige	1008	7OF1212-1008	7OF1216-1008	7OF1206-1008	7OF1606-1008
Tortora Dove-grey Taupe	2005	7OF1212-2005	7OF1216-2005	7OF1206-2005	7OF1606-2005

Pannelli con imbottitura interna in poliester a **densità variabile** Snowsound® Technology. Rivestimento esterno in tessuto di poliester Trevira CS®. Completi di struttura in acciaio e kit per fissaggio a soffitto composto da: 4 piastre a soffitto a 2 fori - 4 cavi in acciaio - 4 attacchi per telaio.





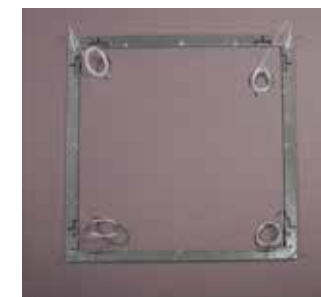

Panel with polyester internal padding with Snowsound® Technology **variable density**. Polyester covering in Trevira CS® fabric. Equipped with steelframe and Kit for the ceiling fixing composed of: 4 ceiling plates with 2 holes, 4 steel cables, 4 hangings for frame.

Panneau avec rembourrage interne en polyester à **densité variable** Snowsound® Technology. Revêtement externe en tissu de polyester Trevira CS®. Fourni avec structure en acier et kit d'accrochage au plafond composé de: 4 platines pour plafond à 2 trous - 4 câbles en acier - 4 accrochages pour cadre

Panel con acolchado interior de poliéster de **densidad variable** Snowsound® Technology. Revestimiento exterior en tejido de poliéster Trevira CS®. Completo de estructura de acero y kit para el montaje al techo compuesto por: 4 placas de techo con 2 huecos - 4 cables de acero - 4 enganches para bastidor.

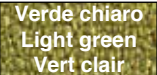
Panel mit Polyester-Füllmaterial von **unterschiedlicher Dichte** Snowsound® Technology. Polyester-Bezug aus Trevira CS®-Material. Ausgestattet mit Gestell aus Stahl und Set für die Deckenbefestigung bestehend aus: 4 Deckenmontageplatten mit 2 Befestigungsbohrungen, 4 Stahlseile, 4 Befestigungen für den Rahmen.



Colore Colour	Codice/Code Prezzo/Price	Codice/Code Prezzo/Price	Codice/Code Prezzo/Price	Codice/Code Prezzo/Price
 Giallo Yellow Jaune 3008	7OF1212-3008	7OF1216-3008	7OF1206-3008	7OF1606-3008
 Arancione Orange Orange 4030	7OF1212-4030	7OF1216-4030	7OF1206-4030	7OF1606-4030
 Rosso Red Rouge 4027	7OF1212-4027	7OF1216-4027	7OF1206-4027	7OF1606-4027
 Verde chiaro Light green Vert clair 7004	7OF1212-7004	7OF1216-7004	7OF1206-7004	7OF1606-7004
 Verde Green Vert 7013	7OF1212-7013	7OF1216-7013	7OF1206-7013	7OF1606-7013
 Blu Blue Bleu 6071	7OF1212-6071	7OF1216-6071	7OF1206-6071	7OF1606-6071
 Nero Black Noir 8033	7OF1212-8033	7OF1216-8033	7OF1206-8033	7OF1606-8033

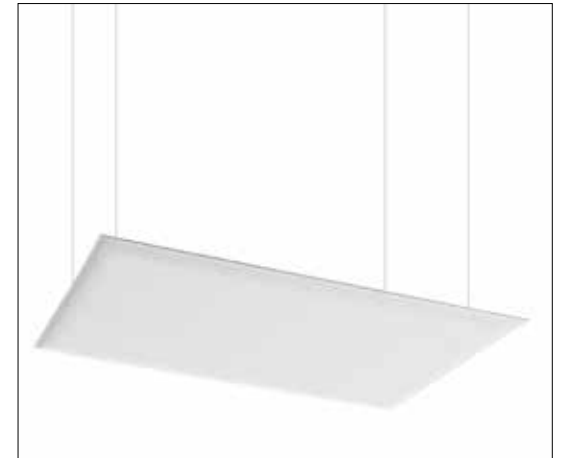

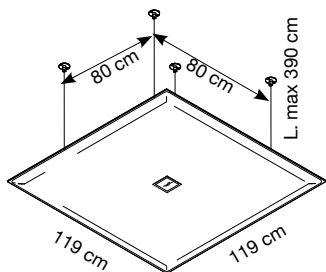

Colore Colour	Codice/Code Prezzo/Price
Bianco White Blanc	0001
Grigio argento Silver grey Gris argenté	8004
Grigio scuro Dark grey Gris foncé	8007
Beige Beige Beige	1008
Tortora Dove-grey Taupe	2005
Giallo Yellow Jaune	3008
Arancione Orange Orange	4030
Rosso Red Rouge	4027
Verde chiaro Light green Vert clair	7004
Verde Green Vert	7013
Blu Blue Bleu	6071
Nero Black Noir	8033

Pannelli con imbottitura interna in poliester a **densità variabile** Snowsound® Technology. Rivestimento esterno in tessuto di poliester Trevira CS®. Faretto LED quadrato potenza 9,4W, 3000K, realizzato in metallo verniciato con polveri epossidiche bianco opaco, con schermi diffusori satinati. Completati di struttura in acciaio e kit per fissaggio a soffitto composto da: 4 piastre a soffitto a 2 fori - 4 cavi in acciaio - 4 attacchi per telaio. Cavo di alimentazione L. 390 cm.

OPZIONALE: rosone, vedi pag. 120

Panel with polyester internal padding with Snowsound® Technology **variable density**. Polyester covering in Trevira CS® fabric. 1 square LED spotlight, 9.4W power, 3000K, made of epoxy powder-coated, with satin-finish diffuser shields. Equipped with steelframe and Kit for the ceiling fixing composed of: 4 ceiling plates with 2 holes, 4 steel cables, 4 hangings for frame. Length of power supply cable: 390 cm. **OPTIONAL: ceiling rose, see page. 120**

Panneau avec rembourrage interne en polyester à **densité variable** Snowsound® Technology. Revêtement externe en tissu de polyester Trevira CS®. 1 lumière LED carrée de 9,4W, 3000K, en métal peint en époxy blanc mat, avec écrans diffuseurs satinés. Fourni avec structure en acier et kit d'accrochage au plafond composé de: 4 platines pour plafond à 2 trous - 4 câbles en acier - 4 accrochages pour cadre. Cordon d'alimentation L. 390 cm.

OPTIONNEL: rosace, voir page 120

Panel con acolchado interior de poliéster de **densidad variable** Snowsound® Technology. Revestimiento exterior en tejido de poliéster Trevira CS®. 1 foco LED cuadrados potencia 9,4W, 3000K, de metal barnizado con polvos epoxi blanco opaco, con pantallas difusoras satinadas. Completo de estructura de acero y kit para el montaje al techo compuesto por: 4 placas de techo con 2 huecos - 4 cables de acero - 4 enganches para bastidor. Cable de alimentación L. 390 cm. **OPCIONAL: rosetón, pag. 120**

Panel mit Polyester-Füllmaterial von **unterschiedlicher Dichte** Snowsound® Technology. Polyester-Bezug aus Trevira CS®-Material. 1 viereckige LED-Spots (9,4W, 3000K) aus pulverbeschichtetem mattweiß Metall und mit satinierten Diffusoren. Ausgestattet mit Gestell aus Stahl und Set für die Deckenbefestigung bestehend aus: 4 Deckenmontageplatten mit 2 Befestigungsbohrungen, 4 Stahlseile, 4 Befestigungen für den Rahmen. Netzteil-Länge. 390 cm. **FAKULTATIV: rosette, Seite 120**



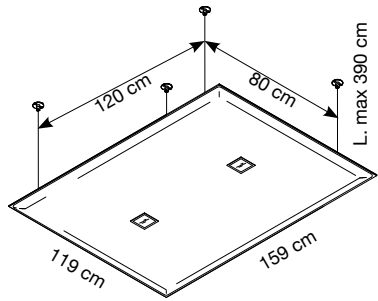

Colore Colour	Codice/Code Prezzo/Price
Bianco White Blanc	0001
Grigio argento Silver grey Gris argenté	8004
Grigio scuro Dark grey Gris foncé	8007
Beige Beige Beige	1008
Tortora Dove-grey Taupe	2005
Giallo Yellow Jaune	3008
Arancione Orange Orange	4030
Rosso Red Rouge	4027
Verde chiaro Light green Vert clair	7004
Verde Green Vert	7013
Blu Blue Bleu	6071
Nero Black Noir	8033

Pannelli con imbottitura interna in poliester a **densità variabile** Snowsound® Technology. Rivestimento esterno in tessuto di poliester Trevira CS®. 2 faretti LED quadrati potenza 9,4W ciascuno, 3000K, realizzati in metallo verniciato con polveri epossidiche bianco opaco, con schermi diffusori satinati. Completi di struttura in acciaio e kit per fissaggio a soffitto composto da: 4 piastre a soffitto a 2 fori - 4 cavi in acciaio - 4 attacchi per telaio. Cavo di alimentazione L. 390 cm. **OPZIONALE: rosone, vedi pag. 120**

Panel with polyester internal padding with Snowsound® Technology **variable density**. Polyester covering in Trevira CS® fabric. 2 square LED spotlights, 9.4W power each, 3000K, made of epoxy powder-coated, with satin-finish diffuser shields. Equipped with steelframe and Kit for the ceiling fixing composed of: 4 ceiling plates with 2 holes, 4 steel cables, 4 hangings for frame. Length of power supply cable: 390 cm. **OPTIONAL: ceiling rose, see page. 120**

Panneau avec rembourrage interne en polyester à **densité variable** Snowsound® Technology. Revêtement externe en tissu de polyester Trevira CS®. 2 lumières LED carrées de 9,4W chacune, 3000K, en métal peint en époxy blanc mat, avec écrans diffuseurs satinés. Fourni avec structure en acier et kit d'accrochage au plafond composé de: 4 platines pour plafond à 2 trous -4 câbles en acier -4 accrochages pour cadre. Cordon d'alimentation L. 390 cm. **OPTIONNEL: rosace, voir page 120.**

Panel con acolchado interior de poliéster de **densidad variable** Snowsound® Technology. Revestimiento exterior en tejido de poliéster Trevira CS®. 2 focos LED cuadrados potencia 9,4W cada uno, 3000K, de metal barnizado con polvos epoxi blanco opaco, con pantallas difusoras satinadas. Completo de estructura de acero y kit para el montaje al techo compuesto por: 4 placas de techo con 2 huecos - 4 cables de acero - 4 enganches para bastidor. Cable de alimentación L. 390 cm. **OPCIONAL: rosetón, pag. 120**

Panel mit Polyester-Füllmaterial von **unterschiedlicher Dichte** Snowsound® Technology. Polyester-Bezug aus Trevira CS®-Material. 2 viereckige LED-Spots (je 9,4W, 3000K) aus pulverbeschichtetem mattweiß Metall und mit satinierten Diffusoren. Ausgestattet mit Gestell aus Stahl und Set für die Deckenbefestigung bestehend aus: 4 Deckenmontageplatten mit 2 Befestigungsbohrungen, 4 Stahlseile, 4 Befestigungen für den Rahmen. Netzteil-Länge. 390 cm. **FAKULTATIV: rosette, Seite 120**



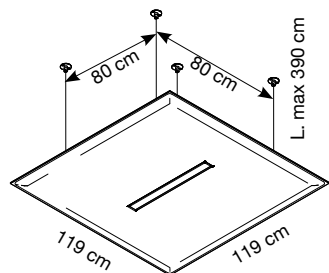

Colore Colour	Codice/Code Prezzo/Price	Codice/Code Prezzo/Price
	NON DIMMERABILE NOT DIMMERABLE	DIMMERABILE* DIMMERABLE*
Bianco White Blanc 0001	7OL1212/L6-0001	7OL1212/D6-0001
Grigio argento Silver grey Gris argenté 8004	7OL1212/L6-8004	7OL1212/D6-8004
Grigio scuro Dark grey Gris foncé 8007	7OL1212/L6-8007	7OL1212/D6-8007
Beige Beige Beige 1008	7OL1212/L6-1008	7OL1212/D6-1008
Tortora Dove-grey Taupe 2005	7OL1212/L6-2005	7OL1212/D6-2005
Giallo Yellow Jaune 3008	7OL1212/L6-3008	7OL1212/D6-3008
Arancione Orange Orange 4030	7OL1212/L6-4030	7OL1212/D6-4030
Rosso Red Rouge 4027	7OL1212/L6-4027	7OL1212/D6-4027
Verde chiaro Light green Vert clair 7004	7OL1212/L6-7004	7OL1212/D6-7004
Verde Green Vert 7013	7OL1212/L6-7013	7OL1212/D6-7013
Blu Blue Bleu 6071	7OL1212/L6-6071	7OL1212/D6-6071
Nero Black Noir 8033	7OL1212/L6-8033	7OL1212/D6-8033

Pannelli con imbottitura interna in poliester a **densità variabile** Snowsound® Technology. Rivestimento esterno in tessuto di poliester Trevira CS®. Con lampada LED rettangolare potenza 17,4W, 3000K, struttura realizzata in alluminio verniciato bianco opaco, con schermo diffusore satinato. Completi di struttura in acciaio e kit per fissaggio a soffitto composto da: 4 piastre a soffitto a 2 fori - 4 cavi in acciaio - 4 attacchi per telaio. Cavo di alimentazione L. 390 cm. **OPZIONALE: rosone, vedi pag. 120**

Panel with polyester internal padding with Snowsound® Technology **variable density**. Polyester covering in Trevira CS® fabric. Rectangular LED lamp, 26.1W power, 3000K, structure made of matt white epoxy powder-coated aluminium, with satin-finish diffuser screen. Equipped with steel frame and Kit for the ceiling fixing composed of: 4 ceiling plates with 2 holes, 4 steel cables, 4 hangings for frame. Length of power supply cable: 390 cm. **OPTIONAL: ceiling rose, see page. 120**

Panneau avec rembourrage interne en polyester à **densité variable** Snowsound® Technology. Revêtement externe en tissu de polyester Trevira CS®. Avec lampe LED rectangulaire de 17,4W, 3000K, structure en aluminium peint blanc mat, avec écran diffuseur satiné. Fourni avec structure en acier et kit d'accrochage au plafond composé de: 4 platines pour plafond à 2 trous - 4 câbles en acier - 4 accrochages pour cadre. Cordon d'alimentation L. 390 cm. **OPTIONNEL: rosace, voir page 120**

Panel con acolchado interior de poliéster de **densidad variable** Snowsound® Technology. Revestimiento exterior en tejido de poliéster Trevira CS®. Con lámpara LED rectangular potencia 17,4W, 3000K, estructura de aluminio barnizado blanco opaco, con pantalla difusora satinada. Completo de estructura de acero y kit para el montaje al techo compuesto por: 4 placas de techo con 2 huecos - 4 cables de acero - 4 enganches para bastidor. Cable de alimentación L. 390 cm. **OPCIONAL: rosetón, pag. 120**

Panel mit Polyester-Füllmaterial von **unterschiedlicher Dichte** Snowsound® Technology. Polyester-Bezug aus Trevira CS®-Material. Mit viereckiger LED-Lampe (17,4 W, 3000K) und satiniertem Diffusor ausgestattete und mattweiß beschichtete Aluminium-Struktur. Ausgestattet mit Gestell aus Stahl und Set für die Deckenbefestigung bestehend aus: 4 Deckenmontageplatten mit 2 Befestigungsbohrungen, 4 Stahlseile, 4 Befestigungen für den Rahmen. Netzteil-Länge. 390 cm. **FAKULTATIV: rosette, Seite 120**

*** DIMMERABLE - DIMMERABLE
SWITCH DIM (PUSH) OR DALI**

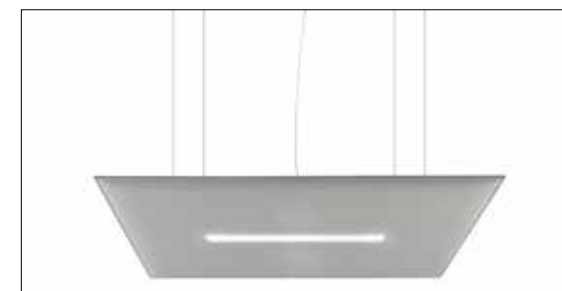

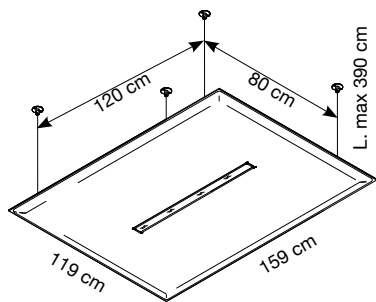

Colore Colour	Codice/Code Prezzo/Price	Codice/Code Prezzo/Price
Bianco White Blanc	0001	NON DIMMERABILE NOT DIMMERABLE
Grigio argento Silver grey Gris argenté	8004	DIMMERABILE* DIMMERABLE*
Grigio scuro Dark grey Gris foncé	8007	
Beige Beige Beige	1008	
Tortora Dove-grey Taupe	2005	
Giallo Yellow Jaune	3008	
Arancione Orange Orange	4030	
Rosso Red Rouge	4027	
Verde chiaro Light green Vert clair	7004	
Verde Green Vert	7013	
Blu Blue Bleu	6071	
Nero Black Noir	8033	

Pannelli con imbottitura interna in poliester a **densità variabile** Snow-sound® Technology. Rivestimento esterno in tessuto di poliester Trevira CS®. Con lampada LED rettangolare potenza 26,1W, 3000K, struttura realizzata in alluminio verniciato bianco opaco, con schermo diffusore satinato. Completi di struttura in acciaio e kit per fissaggio a soffitto composto da: 4 piastre a soffitto a 2 fori - 4 cavi in acciaio - 4 attacchi per telaio. Cavo di alimentazione L. 390 cm. **OPZIONALE: rosone, vedi pag. 120**

Panel with polyester internal padding with Snowsound® Technology **variable density**. Polyester covering in Trevira CS® fabric. Rectangular LED lamp, 26.1W power, 3000K, structure made of matt white epoxy powder-coated aluminium, with satin-finish diffuser screen. Equipped with steelframe and Kit for the ceiling fixing composed of: 4 ceiling plates with 2 holes, 4 steel cables, 4 hangings for frame. Length of power supply cable: 390 cm. **OPTIONAL: ceiling rose, see page. 120**

Panneau avec rembourrage interne en polyester à **densité variable** Snow-sound® Technology. Revêtement externe en tissu de polyester Trevira CS®. Avec lampe LED rectangulaire de 26,1W, 3000K, structure en aluminium peint blanc mat, avec écran diffuseur satiné. Fourni avec structure en acier et kit d'accrochage au plafond composé de: 4 platines pour plafond à 2 trous - 4 câbles en acier - 4 accrochages pour cadre. Cordon d'alimentation L. 390 cm. **OPTIONNEL: rosace, voir page 120**

Panel con acolchado interior de poliéster de **densidad variable** Snowsound® Technology. Revestimiento exterior en tejido de poliéster Trevira CS®. Con lámpara LED rectangular potencia 26,1W, 3000K, estructura de aluminio barnizado blanco opaco, con pantalla difusora satinada. Completo de estructura de acero y kit para el montaje al techo compuesto por: 4 placas de techo con 2 huecos - 4 cables de acero - 4 enganches para bastidor. Cable de alimentación L. 390 cm. **OPCIONAL: rosetón, pag. 120**

Panel mit Polyester-Füllmaterial von **unterschiedlicher Dichte** Snow-sound® Technology. Polyester-Bezug aus Trevira CS®-Material. Mit viereckiger LED-Lampe (26,1W, 3000K) und satiniertem Diffusor ausgestattet und mattweiß beschichtete Aluminium-Struktur. Ausgestattet mit Gestell aus Stahl und Set für die Deckenbefestigung bestehend aus: 4 Deckenmontageplatten mit 2 Befestigungsbohrungen, 4 Stahlseile, 4 Befestigungen für den Rahmen. Netzteil-Länge. 390 cm. **FAKULTATIV: rosette, Seite 120**

*** DIMMERABILE - DIMMERABLE
SWITCH DIM (PUSH) OR DALI**

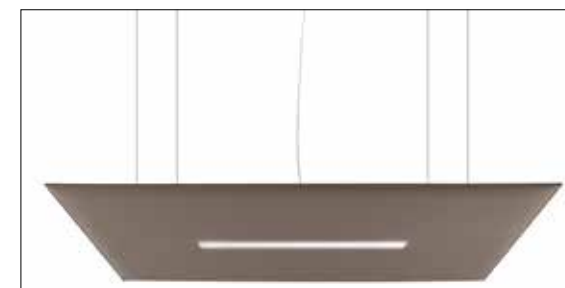

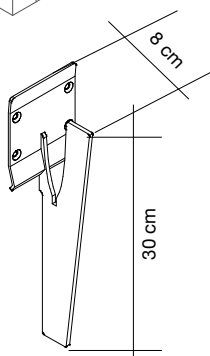
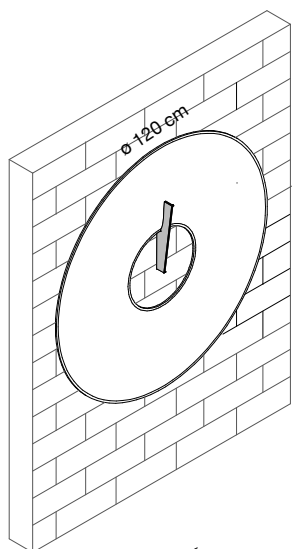

Dettaglio supporto
Fixing detail

Codice/Code
Prezzo/Price



**Supporto nero
micaceo
Micaceous black
fixing**

Codice/Code
Prezzo/Price



**Supporto cromato
Chrome-plated
fixing**

Colore
Colour



**Bianco
White
Blanc**

0001

7GW120NM-0001

7GW120C-0001



**Grigio argento
Silver grey
Gris argenté**

8004

7GW120NM-8004

7GW120C-8004



**Beige
Beige
Beige**

1008

7GW120NM-1008

7GW120C-1008



**Arancione
Orange
Orange**

4030

7GW120NM-4030

7GW120C-4030

Pannelli con imbottitura interna in poliester a **densità variabile** Snowsound® Technology. Rivestimento esterno in tessuto di poliester Trevira CS®. Completi di supporto di fissaggio a parete in acciaio cromato o nero micaceo.

Panel with polyester internal padding with Snowsound® Technology **variable density**. Polyester covering in Trevira CS® fabric. Complete with wall mounting bracket in chrome-plated steel or black micaceous finish.

Panneau avec rembourrage interne en polyester à **densité variable** Snowsound® Technology. Revêtement externe en tissu de polyester Trevira CS®. Fourni avec support pour fixation murale en acier chromé ou noir micacé.

Panel con acolchado interior de poliéster de **densidad variable** Snowsound® Technology. Revestimiento exterior en tejido de poliéster Trevira CS®. Se completa con un soporte de fijación mural de acero cromado o negro mica.

Panel mit Polyester-Füllmaterial von **unterschiedlicher Dichte** Snowsound® Technology. Polyester-Bezug aus Trevira CS®-Material. Wandbefestigungslager-Kit aus verchromtem oder Eisenglimmer-schwarz beschichtetem Stahl.





Supporto nero micaceo
Micaceous Black fixing



Supporto cromato
Chrome-plated fixing



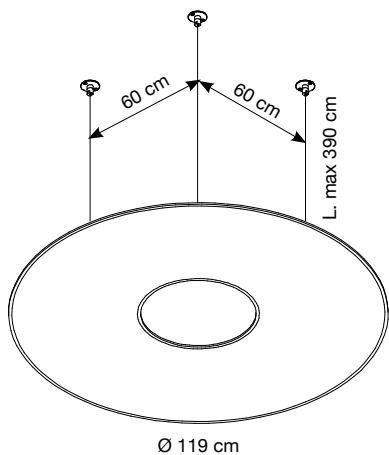

Colore
Colour

Codice/Code
Prezzo/Price



Bianco
White
Blanc

0001

7GF120-0001



Grigio argento
Silver grey
Gris argenté

8004

7GF120-8004



Beige
Beige
Beige

1008

7GF120-1008



Arancione
Orange
Orange

4030

7GF120-4030

Pannelli con imbottitura interna in poliester a **densità variabile** Snowsound® Technology. Rivestimento esterno in tessuto di poliester Trevira CS®. Completi di struttura in acciaio e kit per fissaggio a soffitto composto da: 3 piastre a soffitto a 2 fori - 3 cavi in acciaio - 3 attacchi per telaio.

Panel with polyester internal padding with Snowsound® Technology **variable density**. Polyester covering in Trevira CS® fabric. Equipped with steelframe and Kit for the ceiling fixing composed of: 3 ceiling plates with 2 holes, 3 steel cables, 3 hangings for frame.

Panneau avec rembourrage interne en polyester à **densité variable** Snowsound® Technology. Revêtement externe en tissu de polyester Trevira CS®. Fourni avec structure en acier et kit d'accrochage au plafond composé de: 3 platines pour plafond à 2 trous - 3 câbles en acier - 3 accrochages pour cadre

Panel con acolchado interior de poliéster de **densidad variable** Snowsound® Technology. Revestimiento exterior en tejido de poliéster Trevira CS®.

Completo de estructura de acero y kit para el montaje al techo compuesto por: 3 placas de techo con 2 huecos - 3 cables de acero - 3 enganches para bastidor.

Panel mit Polyester-Füllmaterial von **unterschiedlicher Dichte** Snowsound® Technology. Polyester-Bezug aus Trevira CS®-Material. Ausgestattet mit Gestell aus Stahl und Set für die Deckenbefestigung bestehend aus: 3 Deckenmontageplatten mit 2 Befestigungsbohrungen, 3 Stahlseile, 3 Befestigungen für den Rahmen. Netzteil-Länge. 390 cm

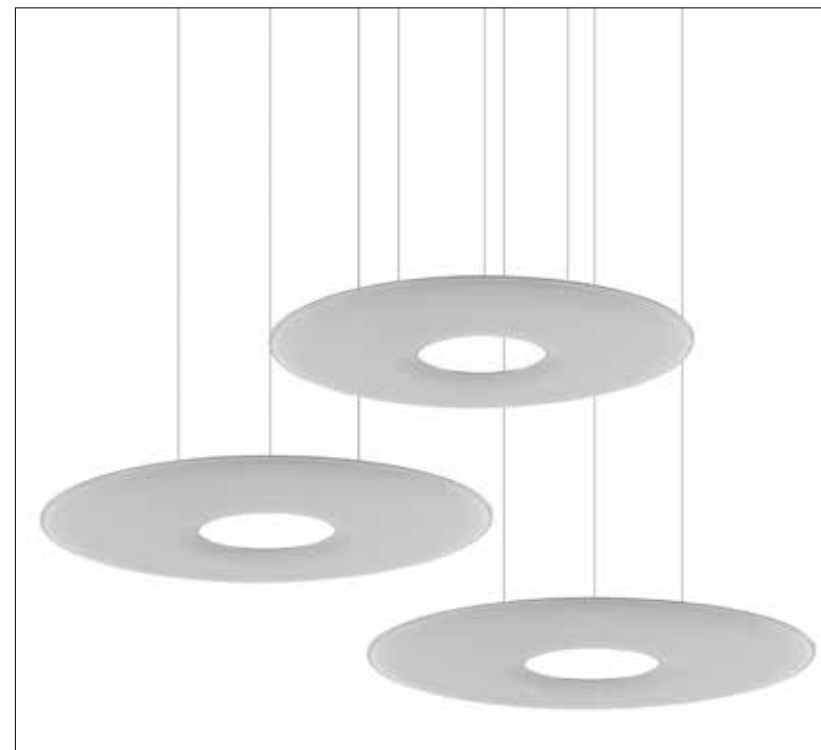

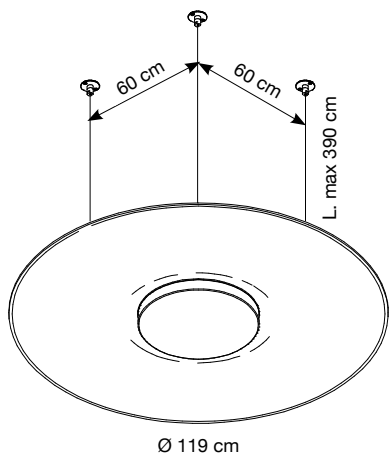

Colore Colour	Codice/Code Prezzo/Price	Codice/Code Prezzo/Price
 Bianco White Blanc 0001	7GL120-0001	7GL120/D-0001
 Grigio argento Silver grey Gris argenté 8004	7GL120-8004	7GL120/D-8004
 Beige Beige Beige 1008	7GL120-1008	7GL120/D-1008
 Arancione Orange Orange 4030	7GL120-4030	7GL120/D-4030

Pannelli con imbottitura interna in poliester a **densità variabile** Snowsound® Technology. Rivestimento esterno in tessuto di poliester Trevira CS®, con corpo illuminante circolare in metallo verniciato con sorgente luminosa a luce LED, potenza 25,3W, 3000K, con diffusore satinato bianco opaco. Completi di struttura in acciaio e kit per fissaggio a soffitto composto da: 3 piastre a soffitto a 2 fori - 3 cavi in acciaio - 3 attacchi per telaio. Cavo di alimentazione L. 390 cm. **OPZIONALE: rosone, vedi pag. 120**

Panel with polyester internal padding with Snowsound® Technology **variable density**. Polyester covering in Trevira CS® fabric with circular epoxy powder-coated metal illuminating body with LED light source, 25.3W power, 3000K, with matt white satin-finish diffuser. Equipped with steelframe and Kit for the ceiling fixing composed of: 3 ceiling plates with 2 holes, 3 steel cables, 3 hangings for frame. Length of power supply cable: 390 cm. **OPTIONAL: ceiling rose, see page. 120**

Panneau avec rembourrage interne en polyester à **densité variable** Snowsound® Technology. Revêtement externe en tissu de polyester Trevira CS® avec lampadaire circulaire en métal peint à lampe LED 25,3W, 3000K, diffuseur satiné blanc mat. Fourni avec structure en acier et kit d'accrochage au plafond composé de: 3 platines pour plafond à 2 trous - 3 câbles en acier - 3 accrochages pour cadre. Cordon d'alimentation L. 390 cm. **OPTIONNEL: rosace, voir page 120**

Panel con acolchado interior de poliéster de **densidad variable** Snowsound® Technology. Revestimiento exterior en tejido de poliéster Trevira CS® con centro iluminante circular de metal barnizado y fuente luminosa de luz LED, potencia 25,3W, 3000K, con difusor satinado blanco opaco. Completo de estructura de acero y kit para el montaje al techo compuesto por: 3 placas de techo con 2 huecos - 3 cables de acero - 3 enganches para bastidor. Cable de alimentación L. 390 cm. **OPCIONAL: rosetón, pag. 120**

Panel mit Polyester-Füllmaterial von **unterschiedlicher Dichte** Snowsound® Technology. Polyester-Bezug aus Trevira CS®-Material mit rundem Beleuchtungskörper aus beschichtetem Metall und Led-Beleuchtungskörper (25,3W, 3000K), mit mattweißem satiniertem Diffusor. Ausgestattet mit Gestell aus Stahl und Set für die Deckenbefestigung bestehend aus: 3 Deckenmontageplatten mit 2 Befestigungsbohrungen, 3 Stahlseile, 3 Befestigungen für den Rahmen. Netzteil-Länge. 390 cm. **FAKULTATIV: rosette, Seite 120**

*** DIMMERABLE - DIMMERABLE
SWITCH DIM (PUSH) OR DALI**



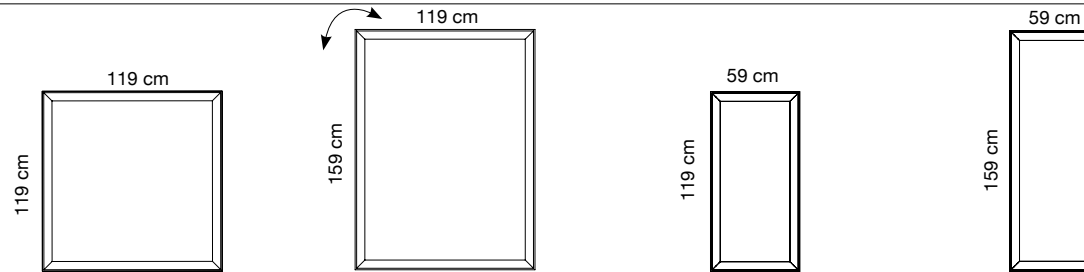

Colore Colour	Codice/Code Prezzo/Price	Codice/Code Prezzo/Price	Codice/Code Prezzo/Price	Codice/Code Prezzo/Price	
Bianco White Blanc	0001	7B1212-0001	7B1216-0001	7B1206-0001	7B1606-0001
Grigio argento Silver grey Gris argenté	8004	7B1212-8004	7B1216-8004	7B1206-8004	7B1606-8004
Grigio scuro Dark grey Gris foncé	8007	7B1212-8007	7B1216-8007	7B1206-8007	7B1606-8007
Beige Beige Beige	1008	7B1212-1008	7B1216-1008	7B1206-1008	7B1606-1008
Tortora Dove-grey Taupe	2005	7B1212-2005	7B1216-2005	7B1206-2005	7B1606-2005
Giallo Yellow Jaune	3008	7B1212-3008	7B1216-3008	7B1206-3008	7B1606-3008
Arancione Orange Orange	4030	7B1212-4030	7B1216-4030	7B1206-4030	7B1606-4030
Rosso Red Rouge	4027	7B1212-4027	7B1216-4027	7B1206-4027	7B1606-4027
Verde chiaro Light green Vert clair	7004	7B1212-7004	7B1216-7004	7B1206-7004	7B1606-7004
Verde Green Vert	7013	7B1212-7013	7B1216-7013	7B1206-7013	7B1606-7013
Blu Blue Bleu	6071	7B1212-6071	7B1216-6071	7B1206-6071	7B1606-6071
Nero Black Noir	8033	7B1212-8033	7B1216-8033	7B1206-8033	7B1606-8033

Pannello con imbottitura interna in poliester a **densità variabile** Snowsound® Technology. Rivestimento esterno in tessuto di poliester Trevira CS®.

Panel with polyester internal padding with Snowsound® Technology **variable density**. Polyester covering in Trevira CS® fabric.

Panneau avec rembourrage interne en polyester à **densité variable** Snowsound® Technology. Revêtement externe en tissu de polyester Trevira CS®.

Panel con acolchado interior de poliéster de **densidad variable** Snowsound® Technology. Revestimiento exterior de tejido de poliéster Trevira CS®.

Paneel mit Polyester-Füllmaterial von **unterschiedlicher Dichte** Snowsound® Technology. Polyester-Bezug aus Trevira CS®-Material.

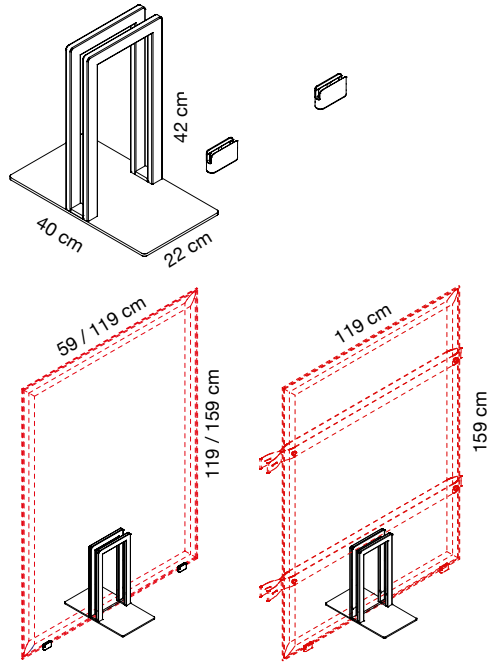

7BB350-GA
Grigio argento
Silver grey
Gris argenté
Gris plata
Silbergrau

7BB350-BO
Bianco opaco
Mat white
Blanc mat
Blanco mate
Mattweiß

Cavalletto in acciaio verniciato con polveri epossidiche completo di piedini di appoggio in tecnopolimero.
Per pannelli Pli Oversize pag. 56.

Stand in epoxy powder-coated steel, complete with hi-tech polymer and steel small feet to be applied to the panel.
For Pli Oversize panels page 56.

Chevalet en acier peint en époxy, avec vérins d'appui en technopolymère et acier à appliquer au panneau.
Pour panneaux Pli Oversize page 56.

Soporte de acero pintado en epoxi, completo con patas de apoyo en tecnopolímero y acero para aplicarse al panel.
Para panels Pli Oversize pag. 56.

Standfuß aus pulverbeschichtetem Stahl mit Stützfüßen aus Technopolymer und Stahl, der an das Paneel befestigt wird.
Für Pli Oversize Paneele, Seite 56.

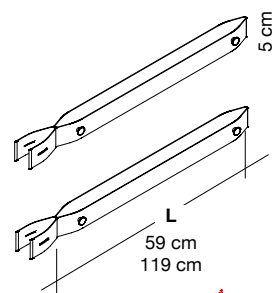

7BC300/1-GR

Per pannelli
For panels
L. 59 cm

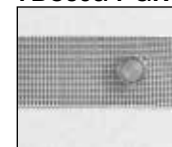

Coppia cinghie elastiche in tecnopolimero per pannelli Pli Oversize pag. 56.

Couple of hi-tech polymer elastic straps for Pli Oversize panels page 56.

Paire de sangles élastiques en technopolymère pour panneaux Pli Oversize page 56.

Par de correas elásticas en tecnopolímero para panels Pli Oversize pag. 56.

7BC312/1-GR

Per pannelli
For panels
L. 119 cm

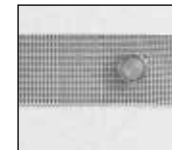

Elastisches Riemen-Paar aus Technopolymer für Pli Oversize Paneele, Seite 56.

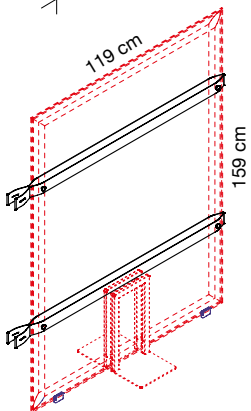

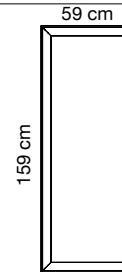
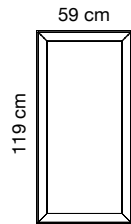

Colore Colour	Codice/Code Prezzo/Price	Codice/Code Prezzo/Price
Bianco White Blanc	0001	7B1206-0001
Grigio argento Silver grey Gris argenté	8004	7B1206-8004
Grigio scuro Dark grey Gris foncé	8007	7B1206-8007
Beige Beige Beige	1008	7B1206-1008
Tortora Dove-grey Taupe	2005	7B1206-2005
Giallo Yellow Jaune	3008	7B1206-3008
Arancione Orange Orange	4030	7B1206-4030
Rosso Red Rouge	4027	7B1206-4027
Verde chiaro Light green Vert clair	7004	7B1206-7004
Verde Green Vert	7013	7B1206-7013
Blu Blue Bleu	6071	7B1206-6071
Nero Black Noir	8033	7B1206-8033

Pannello con imbottitura interna in poliester a **densità variabile** Snowsound® Technology. Rivestimento esterno in tessuto di poliester Trevira CS®.

Panel with polyester internal padding with Snowsound® Technology **variable density**. Polyester covering in Trevira CS® fabric.

Panneau avec rembourrage interne en polyester à **densité variable** Snowsound® Technology. Revêtement externe en tissu de polyester Trevira CS®.

Panel con acolchado interior de poliéster de **densidad variable** Snowsound® Technology. Revestimiento exterior de tejido de poliéster Trevira CS®.

Panel mit Polyester-Füllmaterial von **unterschiedlicher Dichte** Snowsound® Technology. Polyester-Bezug aus Trevira CS®-Material.

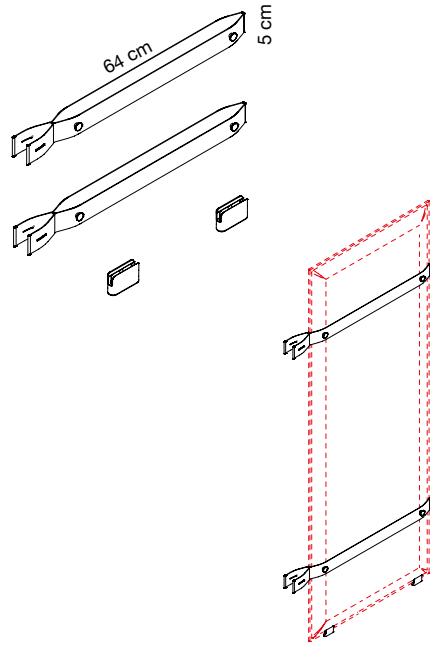

7BC300-N



7BC300-GR

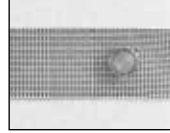

7BC300-BE



Coppia cinghie elastiche in tecnopolimero e piedini di appoggio a terra per **pannelli PLI pag. 58.**

Pair of elastic hi-tech polymer straps and small support feet for **PLI panels page 58.**

Paire de sangles élastiques en technopolymère et verins pour appui au sol pour **panneaux PLI page 58.**

Set de 2 cintas elásticas en tecnopolímero con un pequeño soporte de pie para **paneles PLI page 58.**

Elastisches Riemen-Paar aus Technopolymer und kleine Standfüße für **PLI Paneele Seite 58.**

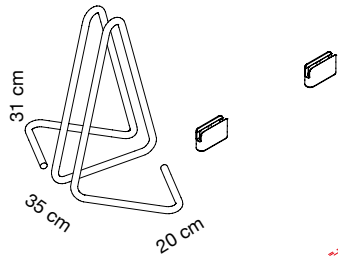

7BB320-C

Cromato
Chrome-plated
Chromé
Cromado
Verchromt

**Per pannelli
For panels
L. 59 cm**

Cavalletto in acciaio cromato piedini di appoggio a terra per composizioni PLI. Obbligatorio per composizioni in linea o non autoportanti. **Per pannelli PLI pag. 58.**

Chrome-plated steel stand and small support feet for PLI. Always required for in-line or not self-supporting compositions. **For PLI panels page 58.**

Chevalet en acier chromé et verins pour appui au sol pour compositions PLI. Obligatoire pour compositions en ligne ou non-autoportantes. **Pour panneaux PLI page 58.**

Base en acero cromado con un pequeño soporte de pie para composiciones PLI. Siempre para ser colocado en línea o en composiciones que no se soporten por sí solas. **Para paneles PLI page 58.**

Verchromter Standfuß und kleine Standfüße für PLI. Immer erforderlich für linear aufgestellte bzw. anderweitig nicht hinreichend stabile Zusammenstellungen. **Für PLI Paneele Seite 58.**

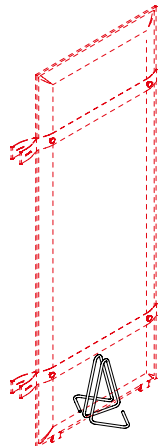

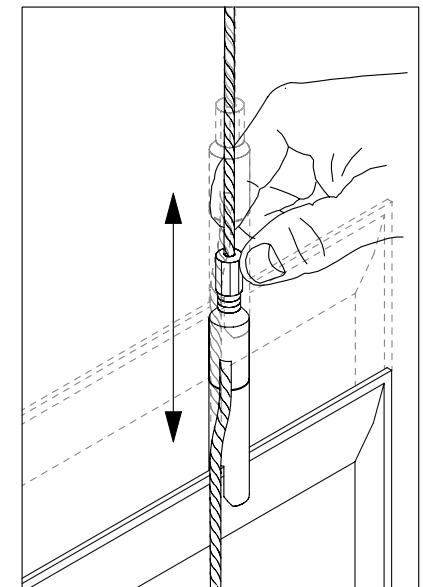

Altezza regolabile
Adjustable height

Pannello con imbottitura interna in poliester a **densità variabile** Snowsound® Technology. Rivestimento esterno in tessuto di poliester Trevira CS®. Completi di kit per fissaggio a soffitto dei pannelli composto da: 2 attacchi a soffitto filettati M6 - 2 cavi in acciaio -2 attacchi per pannello. Il pannello può essere fissato agli attacchi sia verticalmente che orizzontalmente. Gli attacchi si fissano lungo il pannello.

Panel with polyester internal padding with **variable density** Snowsound® Technology. Polyester covering in Trevira CS® fabric. Equipped with kit for the ceiling fixing for panels composed of: 2 ceiling hanging threaded M6, 2 steel cables, 2 hangings for panel. The panel can be clamped at both vertically and horizontally. The brackets are positioned along the panel.

Panneau avec rembourrage interne en polyester à **densité variable** Snowsound® Technology. Revêtement externe en tissu de polyester Trevira CS®. Fourni avec kit d'accrochage au plafond des panneaux composé de: 2 accrochages au plafond filetés M6 – 2 câbles en acier – 2 accrochages pour panneau. Le panneau peut se fixer aux joints en vertical ou horizontal. Les joints se fixent le long du panneau.

Panel con acolchado interior de poliéster de **densidad variable** Snowsound® Technology. Revestimiento exterior en tejido de poliéster Trevira CS®. Completo de kit para el montaje al techo por paneles compuesto por: 2 enganches al techo roscados M6 – 2 cables de acero - 2 enganches para panel. El panel puede ser enganchado tanto en vertical como en horizontal. Los soportes se posicionan a lo largo del panel.

Panel mit Polyester-Füllmaterial von **unterschiedlicher Dichte** Snowsound® Technology. Polyester-Bezug aus Trevira CS®-Material. Ausgestattet mit Set für die Deckenbefestigung für Paneel bestehend aus: 2 Deckenbefestigungen für Gewinde M6, 2 Stahlseile, 2 Befestigungen für Paneel. Das Paneel kann sowohl vertikal als auch horizontal befestigt werden. Die Halterungen werden entlang des Paneels montiert.

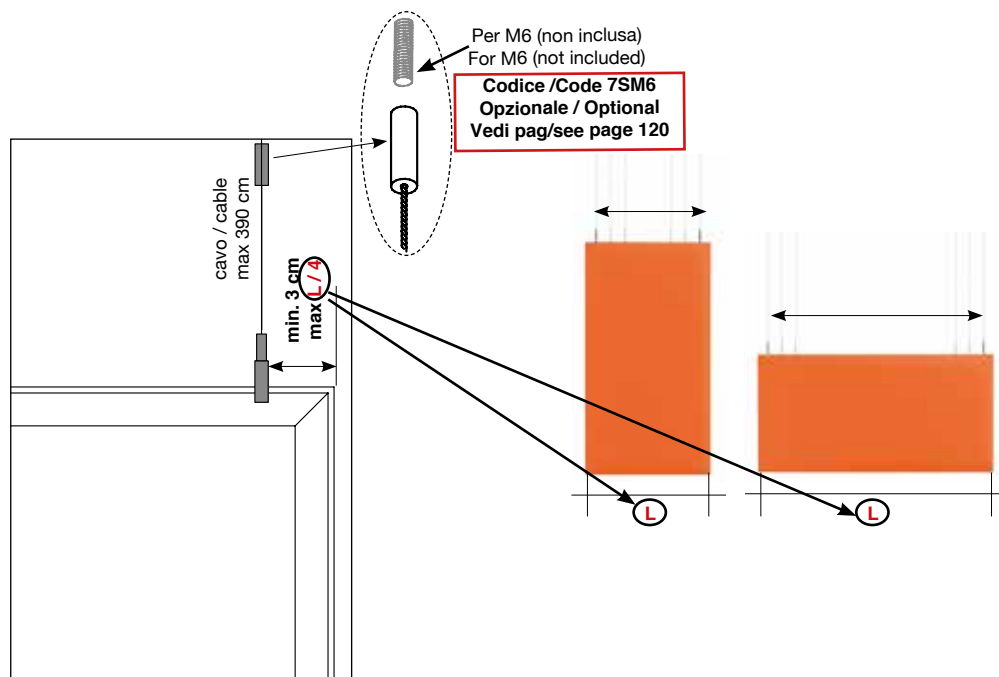

Pannello con imbottitura interna in poliester a **densità variabile** Snowsound® Technology. Rivestimento esterno in tessuto di poliester Trevira CS®. Completi di kit per fissaggio a soffitto dei pannelli composto da: 2 piastre a soffitto a 2 fori - 2 cavi in acciaio -2 attacchi per pannello. Il pannello può essere fissato agli attacchi sia verticalmente che orizzontalmente. Gli attacchi si fissano lungo il pannello.

Panel with polyester internal padding with **variable density** Snowsound® Technology. Polyester covering in Trevira CS® fabric. Equipped with kit for the ceiling fixing for panels composed of: 2 ceiling plates with 2 holes - 2 steel cables - 2 hangings for panel. The panel can be clamped at both vertically and horizontally. The brackets are positioned along the panel.

Panneau avec rembourrage interne en polyester à **densité variable** Snowsound® Technology. Revêtement externe en tissu de polyester Trevira CS®. Fourni avec kit d'accrochage au plafond des panneaux composé de: 2 platines pour plafond à 2 trous – 2 câbles en acier – 2 accrochages pour panneau. Le panneau peut se fixer aux joints en vertical ou horizontal. Les joints se fixent le long du panneau.

Panel con acolchado interior de poliéster de **densidad variable** Snowsound® Technology. Revestimiento exterior en tejido de poliéster Trevira CS®. Completo de kit para el montaje al techo por paneles compuesto por: 2 placas de techo con 2 huecos – 2 cables de acero - 2 enganches para panel. El panel puede ser enganchado tanto en vertical como en horizontal. Los soportes se posicionan a lo largo del panel.

Panel mit Polyester-Füllmaterial von **unterschiedlicher Dichte** Snowsound® Technology. Polyester-Bezug aus Trevira CS®-Material. Ausgestattet mit Set für die Deckenbefestigung für Paneel bestehend aus: 2 Deckenmontageplatten mit 2 Befestigungsbohrungen - 2 Stahlseile - 2 Befestigungen für Paneel. Das Paneel kann sowohl vertikal als auch horizontal befestigt werden. Die Halterungen werden entlang des Paneels montiert.

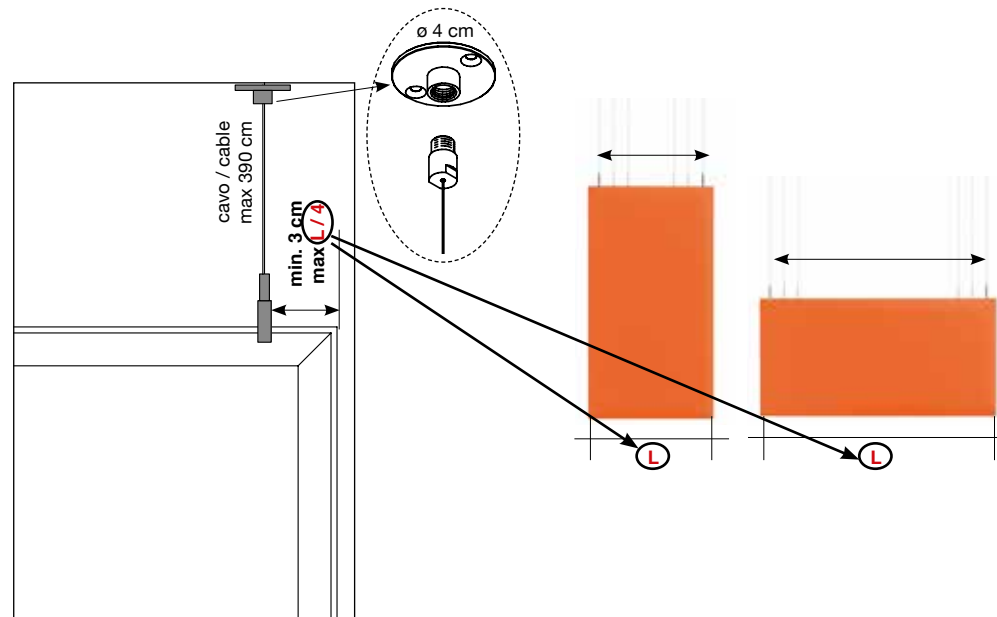

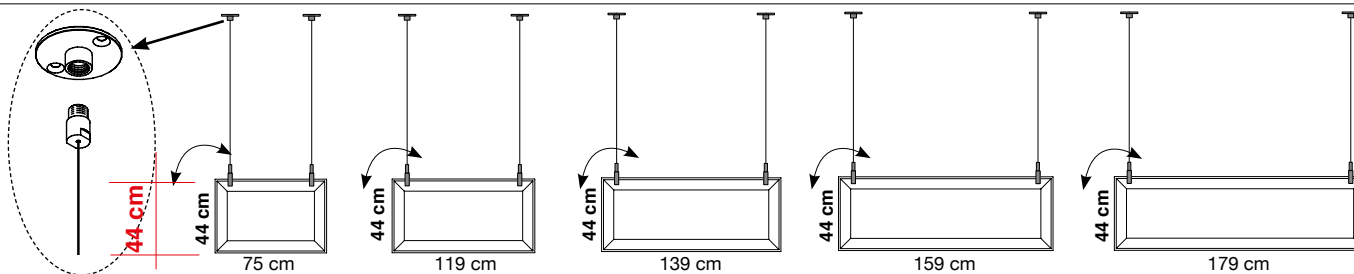

Colore Colour	Codice/Code Prezzo/Price	Codice/Code Prezzo/Price	Codice/Code Prezzo/Price	Codice/Code Prezzo/Price	Codice/Code Prezzo/Price	
Bianco White Blanc	0001	7BF0408-0001	7BF0412-0001	7BF0414-0001	7BF0416-0001	7BF0418-0001
Grigio argento Silver grey Gris argenté	8004	7BF0408-8004	7BF0412-8004	7BF0414-8004	7BF0416-8004	7BF0418-8004
Grigio scuro Dark grey Gris foncé	8007	7BF0408-8007	7BF0412-8007	7BF0414-8007	7BF0416-8007	7BF0418-8007
Beige Beige Beige	1008	7BF0408-1008	7BF0412-1008	7BF0414-1008	7BF0416-1008	7BF0418-1008
Tortora Dove-grey Taupe	2005	7BF0408-2005	7BF0412-2005	7BF0414-2005	7BF0416-2005	7BF0418-2005
Giallo Yellow Jaune	3008	7BF0408-3008	7BF0412-3008	7BF0414-3008	7BF0416-3008	7BF0418-3008
Arancione Orange Orange	4030	7BF0408-4030	7BF0412-4030	7BF0414-4030	7BF0416-4030	7BF0418-4030
Rosso Red Rouge	4027	7BF0408-4027	7BF0412-4027	7BF0414-4027	7BF0416-4027	7BF0418-4027
Verde chiaro Light green Vert clair	7004	7BF0408-7004	7BF0412-7004	7BF0414-7004	7BF0416-7004	7BF0418-7004
Verde Green Vert	7013	7BF0408-7013	7BF0412-7013	7BF0414-7013	7BF0416-7013	7BF0418-7013
Blu Blue Bleu	6071	7BF0408-6071	7BF0412-6071	7BF0414-6071	7BF0416-6071	7BF0418-6071
Nero Black Noir	8033	7BF0408-8033	7BF0412-8033	7BF0414-8033	7BF0416-8033	7BF0418-8033

Pannello con imbottitura interna in poliester a **densità variabile** Snowsound® Technology. Rivestimento esterno in tessuto di poliester Trevira CS®.

Panel with polyester internal padding with Snowsound® Technology **variable density**. Polyester covering in Trevira CS® fabric.

Panneau avec rembourrage interne en polyester à **densité variable** Snowsound® Technology. Revêtement externe en tissu de polyester Trevira CS®.

Panel con acolchado interior de poliéster de **densidad variable** Snowsound® Technology. Revestimiento exterior de tejido de poliéster Trevira CS®.

Panel mit Polyester-Füllmaterial von **unterschiedlicher Dichte** Snowsound® Technology. Polyester-Bezug aus Trevira CS®-Material.

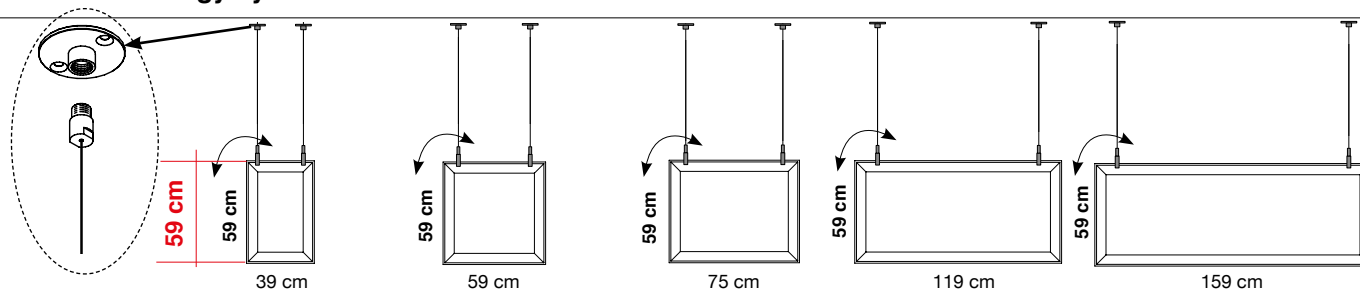

Colore Colour	Codice/Code Prezzo/Price	Codice/Code Prezzo/Price	Codice/Code Prezzo/Price	Codice/Code Prezzo/Price	Codice/Code Prezzo/Price	
Bianco White Blanc	0001	7BF0406-0001	7BF0606-0001	7BF0806-0001	7BF1206-0001	7BF1606-0001
Grigio argento Silver grey Gris argenté	8004	7BF0406-8004	7BF0606-8004	7BF0806-8004	7BF1206-8004	7BF1606-8004
Grigio scuro Dark grey Gris foncé	8007	7BF0406-8007	7BF0606-8007	7BF0806-8007	7BF1206-8007	7BF1606-8007
Beige Beige Beige	1008	7BF0406-1008	7BF0606-1008	7BF0806-1008	7BF1206-1008	7BF1606-1008
Tortora Dove-grey Taupe	2005	7BF0406-2005	7BF0606-2005	7BF0806-2005	7BF1206-2005	7BF1606-2005
Giallo Yellow Jaune	3008	7BF0406-3008	7BF0606-3008	7BF0806-3008	7BF1206-3008	7BF1606-3008
Arancione Orange Orange	4030	7BF0406-4030	7BF0606-4030	7BF0806-4030	7BF1206-4030	7BF1606-4030
Rosso Red Rouge	4027	7BF0406-4027	7BF0606-4027	7BF0806-4027	7BF1206-4027	7BF1606-4027
Verde chiaro Light green Vert clair	7004	7BF0406-7004	7BF0606-7004	7BF0806-7004	7BF1206-7004	7BF1606-7004
Verde Green Vert	7013	7BF0406-7013	7BF0606-7013	7BF0806-7013	7BF1206-7013	7BF1606-7013
Blu Blue Bleu	6071	7BF0406-6071	7BF0606-6071	7BF0806-6071	7BF1206-6071	7BF1606-6071
Nero Black Noir	8033	7BF0406-8033	7BF0606-8033	7BF0806-8033	7BF1206-8033	7BF1606-8033

Pannello con imbottitura interna in poliester a **densità variabile** Snowsound® Technology. Rivestimento esterno in tessuto di poliester Trevira CS®.

Panel with polyester internal padding with Snowsound® Technology **variable density**. Polyester covering in Trevira CS® fabric.

Panneau avec rembourrage interne en polyester à **densité variable** Snowsound® Technology. Revêtement externe en tissu de polyester Trevira CS®.

Panel con acolchado interior de poliéster de **densidad variable** Snowsound® Technology. Revestimiento exterior de tejido de poliéster Trevira CS®.

Panel mit Polyester-Füllmaterial von **unterschiedlicher Dichte** Snowsound® Technology. Polyester-Bezug aus Trevira CS®-Material.

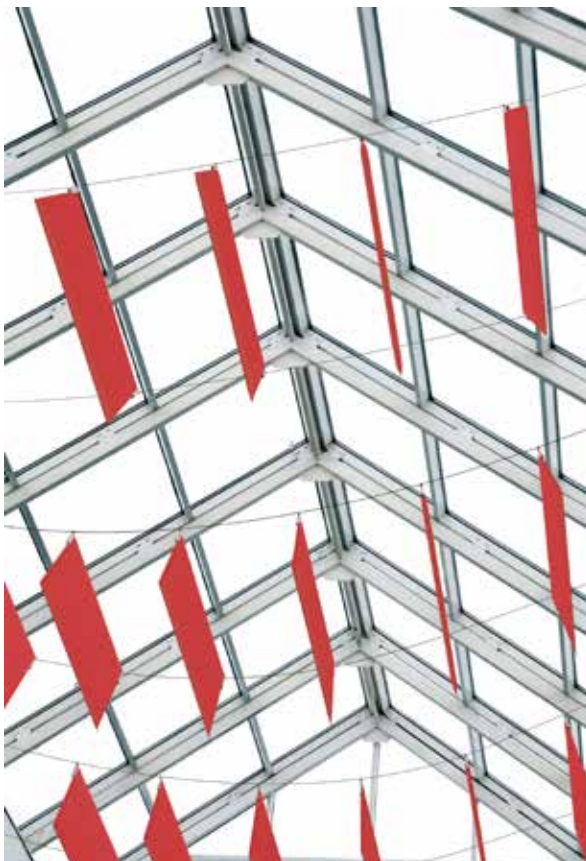

TRA è un prodotto strutturale che richiede accorgimenti specifici per il montaggio. Il nostro ufficio tecnico è a disposizione per qualsiasi informazione.

TRA is a structural product that requires specific mounting devices. Our Technical Department is available for any information.

TRA est un produit structural pour lequel il faut de l'habileté spécifique pour le montage. Notre bureau d'étude est à votre disposition pour tout renseignement.

TRA es un producto estructural que necesita ser instalado en condiciones especiales. Nuestro Dep. tecnico está disponible para cualquier información al respecto.

TRA ist ein strukturelles Produkt, das spezielle Befestigungsvorrichtungen erfordert. Unsere technische Abteilung steht für alle notwendigen Informationen zur Verfügung.



Max. 10 pannelli per coppia di cavi.
Max. 10 panels for each pair of cables.
Max. 10 panneaux pour chaque paire de cables.
Max. 10 Paneele pro Paar-Kabeln.
Max. 10 paneles por 2 cables.

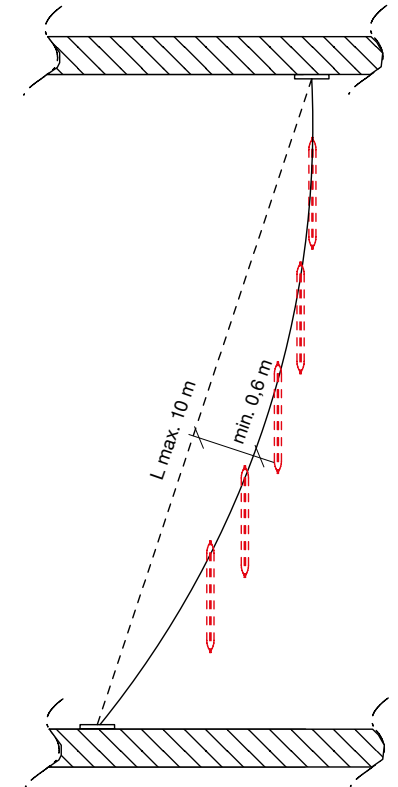
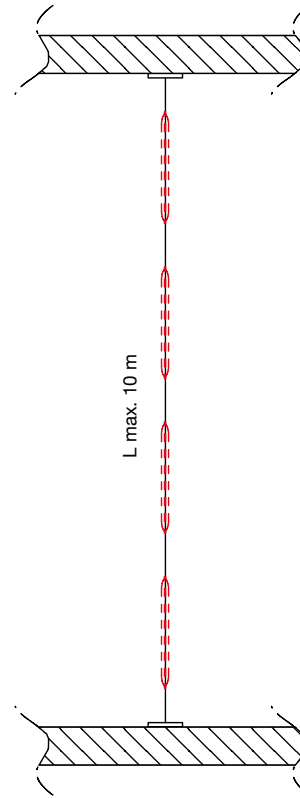
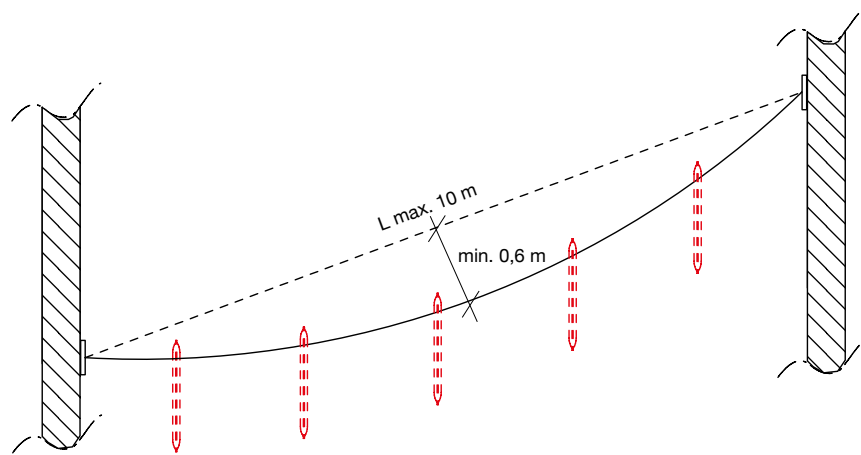
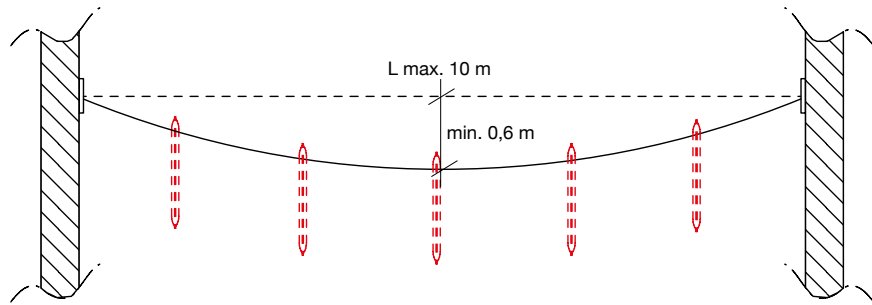

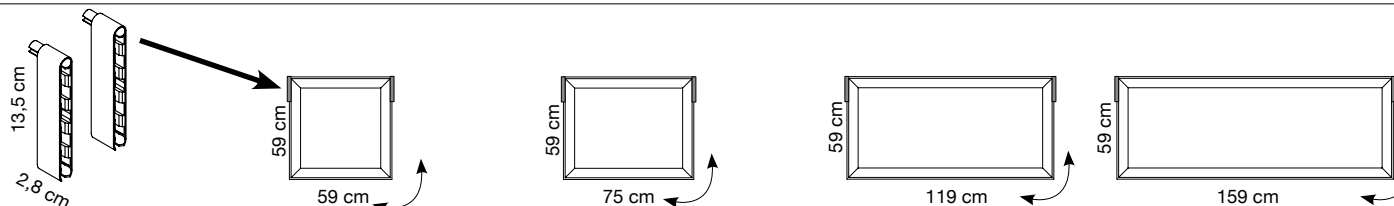

Colore Colour	Codice/Code Prezzo/Price	Codice/Code Prezzo/Price	Codice/Code Prezzo/Price	Codice/Code Prezzo/Price	
 Bianco White Blanc	0001	7BT0606-0001	7BT0806-0001	7BT1206-0001	7BT1606-0001
 Grigio argento Silver grey Gris argenté	8004	7BT0606-8004	7BT0806-8004	7BT1206-8004	7BT1606-8004
 Grigio scuro Dark grey Gris foncé	8007	7BT0606-8007	7BT0806-8007	7BT1206-8007	7BT1606-8007
 Beige Beige Beige	1008	7BT0606-1008	7BT0806-1008	7BT1206-1008	7BT1606-1008
 Tortora Dove-grey Taupe	2005	7BT0606-2005	7BT0806-2005	7BT1206-2005	7BT1606-2005
 Giallo Yellow Jaune	3008	7BT0606-3008	7BT0806-3008	7BT1206-3008	7BT1606-3008
 Arancione Orange Orange	4030	7BT0606-4030	7BT0806-4030	7BT1206-4030	7BT1606-4030
 Rosso Red Rouge	4027	7BT0606-4027	7BT0806-4027	7BT1206-4027	7BT1606-4027
 Verde chiaro Light green Vert clair	7004	7BT0606-7004	7BT0806-7004	7BT1206-7004	7BT1606-7004
 Verde Green Vert	7013	7BT0606-7013	7BT0806-7013	7BT1206-7013	7BT1606-7013
 Blu Blue Bleu	6071	7BT0606-6071	7BT0806-6071	7BT1206-6071	7BT1606-6071
 Nero Black Noir	8033	7BT0606-8033	7BT0806-8033	7BT1206-8033	7BT1606-8033

Pannello con imbottitura interna in poliester a **densità variabile** Snowsound® Technology. Rivestimento esterno in tessuto di poliester Trevira CS®.

Panel with polyester internal padding with Snowsound® Technology **variable density**. Polyester covering in Trevira CS® fabric.

Panneau avec rembourrage interne en polyester à **densité variable** Snowsound® Technology. Revêtement externe en tissu de polyester Trevira CS®.

Panel con acolchado interior de poliéster de **densidad variable** Snowsound® Technology. Revestimiento exterior de tejido de poliéster Trevira CS®.

Panel mit Polyester-Füllmaterial von **unterschiedlicher Dichte** Snowsound® Technology. Polyester-Bezug aus Trevira CS®-Material.

7BT200
Inox

Coppia cavi in acciaio inox ø 5 mm per campata max L. 10 m.

Pair of stainless steel cables ø 5 mm, to reach a maximum span of 10 m.

Paire de cables en acier inox ø 5 mm pour travée max. L. 10 m.

Set de 2 câbles en acero inoxidable ø 5 mm, alcanza un máximo de 10 m.

Ein Paar Edelstahlseile ø 5 mm, für eine maximale Reichweite von 10 m.

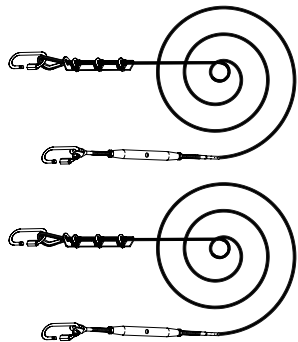

7BT204-GA
Grigio argento
Silver grey
Gris argenté
Gris plata
Silbergrau

Kit 4 piastre in acciaio zincato verniciato con polveri epossidiche per fissaggio cavi 7BT200 a muro.

Set of four epoxy painted galvanized steel plates for cables' 7BT200 wall-fixing.

Jeu de 4 platines en acier zingué peint en époxi pour fixation des cables 7BT200 au mur.

Set de 4 pletinas en acero epoxy galvanizado para fijación a la pared de los cables 7BT200.

Set von vier Montageplatten aus pulverbeschichtetem, verzinktem Stahl für die Wandbefestigung der Edelstahlseile 7BT200.

ø 20 cm

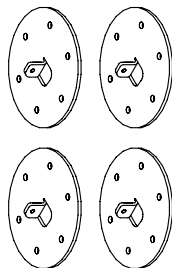



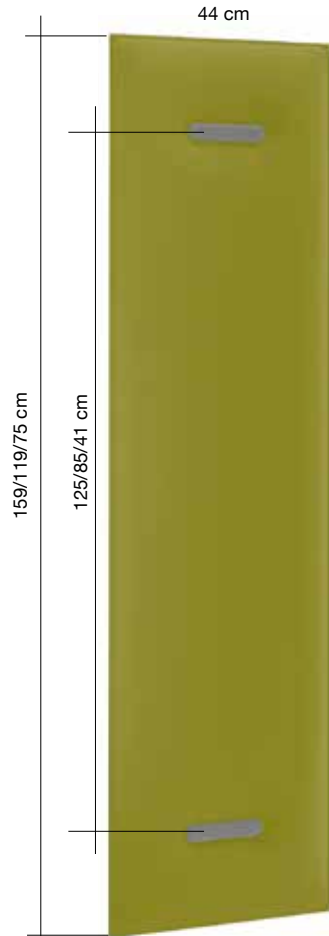







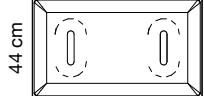
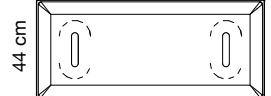

N. 6 fori ø 11 mm
No. 6 holes ø 11 mm



Copertura grigia / Grey cover
Couverture gris / Cobertura gris
Graue Abdeckung

Copertura grigia
Grey cover
Couverture gris
Cobertura gris
Graue Abdeckung

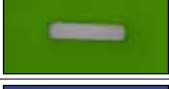
Colore
Colour

		75 cm	119 cm	159 cm
				
		Codice/Code	Codice/Code	Codice/Code
		Prezzo/Price	Prezzo/Price	Prezzo/Price
	Bianco White Blanc 0001	7M1008-0001	7M1012-0001	7M1016-0001
	Grigio argento Silver grey Gris argenté 8004	7M1008-8004	7M1012-8004	7M1016-8004
	Grigio scuro Dark grey Gris foncté 8007	7M1008-8007	7M1012-8007	7M1016-8007
	Beige Beige Beige 1008	7M1008-1008	7M1012-1008	7M1016-1008
	Tortora Dove-grey Taupe 2005	7M1008-2005	7M1012-2005	7M1016-2005
	Giallo Yellow Jaune 3008	7M1008-3008	7M1012-3008	7M1016-3008
	Arancione Orange Orange 4030	7M1008-4030	7M1012-4030	7M1016-4030
	Rosso Red Rouge 4027	7M1008-4027	7M1012-4027	7M1016-4027
	Verde chiaro Light green Vert clair 7004	7M1008-7004	7M1012-7004	7M1016-7004
	Verde Green Vert 7013	7M1008-7013	7M1012-7013	7M1016-7013
	Blu Blue Bleu 6071	7M1008-6071	7M1012-6071	7M1016-6071
	Nero Black Noir 8033	7M1008-8033	7M1012-8033	7M1016-8033

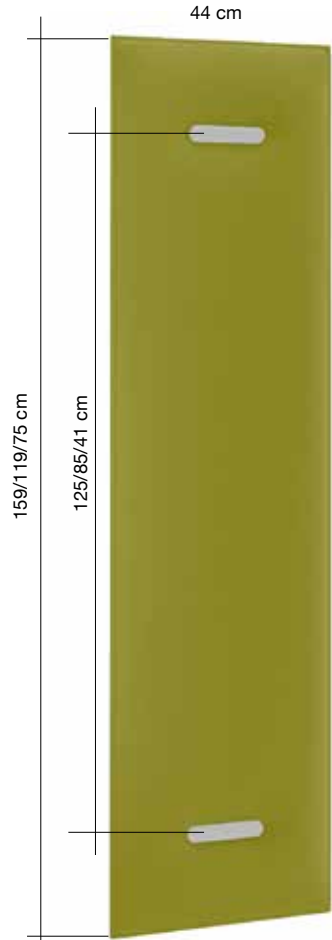

Copertura bianca / White cover
Couverture blanche / Cobertura
blanca / Weisse Abdeckung

Copertura bianca White cover Couverture blanche Cobertura blanca Weisse Abdeckung	Colore Colour	75 cm	119 cm	159 cm
		Codice/Code Prezzo/Price	Codice/Code Prezzo/Price	Codice/Code Prezzo/Price
	Bianco White Blanc 0001	7M1008BO-0001	7M1012BO-0001	7M1016BO-0001
	Grigio argento Silver grey Gris argenté 8004	7M1008BO-8004	7M1012BO-8004	7M1016BO-8004
	Grigio scuro Dark grey Gris foncté 8007	7M1008BO-8007	7M1012BO-8007	7M1016BO-8007
	Beige Beige Beige 1008	7M1008BO-1008	7M1012BO-1008	7M1016BO-1008
	Tortora Dove-grey Taupe 2005	7M1008BO-2005	7M1012BO-2005	7M1016BO-2005
	Giallo Yellow Jaune 3008	7M1008BO-3008	7M1012BO-3008	7M1016BO-3008
	Arancione Orange Orange 4030	7M1008BO-4030	7M1012BO-4030	7M1016BO-4030
	Rosso Red Rouge 4027	7M1008BO-4027	7M1012BO-4027	7M1016BO-4027
	Verde chiaro Light green Vert clair 7004	7M1008BO-7004	7M1012BO-7004	7M1016BO-7004
	Verde Green Vert 7013	7M1008BO-7013	7M1012BO-7013	7M1016BO-7013
	Blu Blue Bleu 6071	7M1008BO-6071	7M1012BO-6071	7M1016BO-6071
	Nero Black Noir 8033	7M1008BO-8033	7M1012BO-8033	7M1016BO-8033

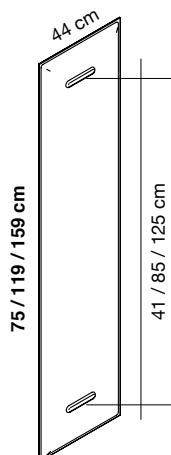

Pannello con imbottitura interna in poliester a **densità variabile** Snowsound® Technology. Rivestimento esterno in tessuto di poliester Trevira CS®.

Completo di attacchi in tecnopolimero e acciaio e coperture frontali in tecnopolimero grigio o bianco.

Il pannello può essere fissato direttamente a parete tramite viti (non incluse). Peso del singolo pannello 2,7 / 2,3 / 1,5 Kg.

Panel with polyester internal padding with Snowsound® Technology **variable density**. Polyester covering in Trevira CS® fabric.

Supplied with connections in high-tech polymer and steel and grey or white high-tech polymer front covers.

The panel can be directly fixed to the wall through screws (not included).

Weight of single panel: 2,7 / 2,3 / 1,5 kg

Panneau avec rembourrage interne en polyester à **densité variable** Snowsound® Technology. Revêtement externe en tissu de polyester Trevira CS®.

Avec jonctions en technopolymère et acier et couvertures frontales en technopolymère gris ou blanc. On peut fixer le panneau directement au mur par des vis (pas incluses). Poids d'un panneau: 2,7 / 2,3 / 1,5 kg

Panel con acolchado interior de poliéster de **densidad variable** Snowsound® Technology. Revestimiento exterior de tejido de poliéster Trevira CS®. Incluye enganches de polímero y acero y coberturas frontales de polímero gris o blanco. El panel puede ser fijado directamente a la pared por medio de tornillos (no incluydos). Peso para singulo panel 2,7 / 2,3 / 1,5 Kg.

Panel mit Polyester-Füllmaterial von **unterschiedlicher Dichte** Snowsound® Technology. Polyester-Bezug aus Trevira CS®-Material. Inklusive Beschlägen aus Technopolymer und Stahl sowie grauen oder weissen Befestigungsabdeckungen aus Technopolymer. Das Paneel kann mit Schrauben (nicht inkludiert) direkt an der Wand montiert werden.

Gewicht eines Paneels: 2,7 / 2,3 / 1,5 kg.



Montaggio semplice a parete pannello Mitesco
Basic wall mounting for Mitesco panel

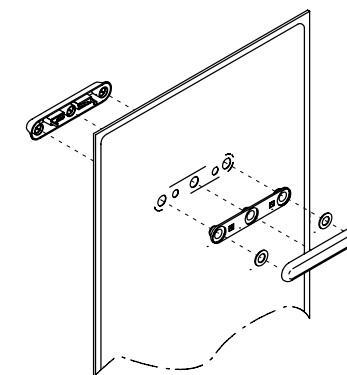

Dettaglio dell'attacco con copertura frontale forniti di serie in colore grigio o bianco.

Le coperture frontali sono disponibili anche colorate cod. 7M102-XXXX (XXXX = Variante colore).

Detail of the connection and front cover in standard grey or white. The front covers are also available in other colors with code 7M102-XXXX (XXXX = Color option).

Détail de la jonction avec couverture frontale, fournie standard en couleur gris ou blanc. Les couvertures frontales sont disponibles aussi dans d'autres couleurs avec réf. 7M102-XXXX (XXXX = option couleur).

Detalle ataque con cobertura frontal incluye en color gris o blanco. Las coberturas frontales son disponibles también en color cod. 7M102-XXXX (XXXX = Variante color).

Detaildarstellung der Befestigungsbeschläge mit standardmäßiger Abdeckung in grau oder weiss. Die Abdeckungen sind auch in anderen Farben erhältlich, Art. 7M102-XXXX (XXXX = Farbvariante).



Dettaglio attacco e copertura frontale colore grigio.

Detail of the connection and front cover. Grey Color.

Détail jonction et couverture frontale, couleur gris.

Detalle ataque y cobertura frontal color gris.

Detaildarstellung der Befestigungsbeschläge und grauer Abdeckung



Dettaglio attacco e copertura frontale colore bianco.

Detail of the connection and front cover. White Color.

Détail jonction et couverture frontale, couleur blanc.

Detalle ataque y cobertura frontal color blanco.

Detaildarstellung der Befestigungsbeschläge und weisser Abdeckung



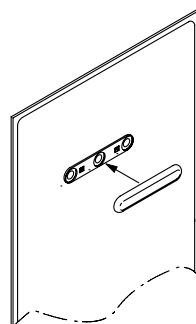
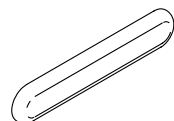
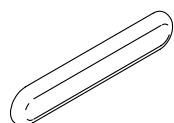

7M102-0001



Bianco
White
Blanc
Weiss
Blanco

1 coppia / 1 pair
1 paire / 1 pare
1 Paar

7M102-4030

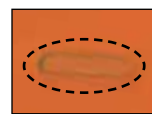

Arancione
Orange
Orange
Anaranjado
Orange

1 coppia / 1 pair
1 paire / 1 pare
1 Paar

7M102-8004



Grigio argento
Silver grey
Gris argenté
Gris plata
Silbergrau

1 coppia / 1 pair
1 paire / 1 pare
1 Paar

7M102-4027



Rosso
Red
Rouge
Rojo
Rot

1 coppia / 1 pair
1 paire / 1 pare
1 Paar

7M102-8007



Grigio scuro
Dark grey
Gris foncé
Gris oscuro
Dunkelgrün

1 coppia / 1 pair
1 paire / 1 pare
1 Paar

7M102-7004

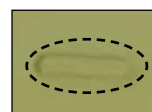

Verde chiaro
Light green
Vert clair
Verde claro
Hellgrün

1 coppia / 1 pair
1 paire / 1 pare
1 Paar

7M102-1008

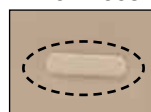

Beige
Beige
Beige
Beige
Beige

1 coppia / 1 pair
1 paire / 1 pare
1 Paar

7M102-7013

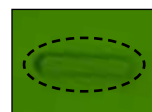

Verde
Green
Vert
Verde
Grüner

1 coppia / 1 pair
1 paire / 1 pare
1 Paar

7M102-2005

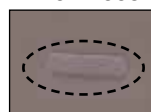

Tortora
Dove-grey
Taupe
Tórtola
Taubengrau

1 coppia / 1 pair
1 paire / 1 pare
1 Paar

7M102-6071

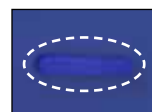

Blu
Blue
Bleu
Azul
Blau

1 coppia / 1 pair
1 paire / 1 pare
1 Paar

7M102-3008

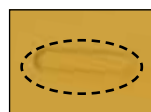

Giallo
Yellow
Jaune
Amarillo
Gelbe

1 coppia / 1 pair
1 paire / 1 pare
1 Paar

7M102-8033



Nero
Black
Noir
Negro
Schwarz

1 coppia / 1 pair
1 paire / 1 pare
1 Paar

Coppia di coperture frontali in tecnopolimero degli attacchi per 1 pannello Mitesco.

OPZIONALE

(Il pannello Mitesco è fornito di serie con le coperture frontali di colore grigio o bianco)

Pair of high-tech polymer front covers for connections for 1 panel Mitesco.

OPTIONAL

(Mitesco panels are supplied as standard with grey or white front covers)

Paire de couvertures frontales en technopolymère pour jonctions pour 1 panneau Mitesco.

OPTIONNEL

(Le panneau Mitesco est fourni en standard avec les couvertures frontales en couleur gris ou blanc)

Par de coberturas frontales de tecnopolimero para enganches de 1 panel Mitesco.

OPCIONAL

(el panel Mitesco ya incluye las coberturas frontales en color gris o blanco)

Paar Abdeckungen aus Technopolymer für Befestigung für 1 Paneel Mitesco.

OPTIONAL erhältlich

(Mitesco-Paneele werden standardmäßig mit grauen oder weissen Befestigungsabdeckungen geliefert).

NOTA

Non utilizzare con staffe scrivania cod. 7M511-XX / 7M515-XX / 7M5100-XX / 7M519-XX / 7M518-XX / 7M517-XX (XX = Variante colore).

Not to be used with desk brackets code 7M511-XX / 7M515-XX / 7M5100-XX / 7M519-XX / 7M518-XX / 7M517-XX (XX = Color option).

Ne pas utiliser avec étriers pour bureau réf 7M511-XX / 7M515-XX / 7M5100-XX / 7M519-XX / 7M518-XX / 7M517-XX (XX = option couleur).

No utilizar con abrazaderas para mesa cod. 7M511-XX / 7M515-XX / 7M5100-XX / 7M519-XX / 7M518-XX / 7M517-XX (XX = Variante color).

Nicht zur Verwendung mit Halterungen für Tisch Art. 7M511-XX / 7M515-XX / 7M5100-XX / 7M519-XX / 7M518-XX / 7M517-XX (XX = Farbvariante).

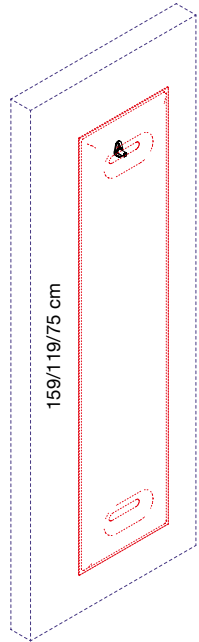

4 cm

**7M210-GR**

Grigio
Grey
Gris
Gris
Grau

Aggancio semplice in tecnopolimero per fissaggio a parete tramite chiodo/vite (non inclusi) di un pannello Mitesco.

Easy connection in high-tech polymer for wall fixing by nail/screw (not included) of 1 Mitesco panel.

Accrochage simple en technopolymère pour fixation au mur par un clou/vis (pas inclus) d'un panneau Mitesco.

Enganche simple de polímero para fijacion a pared por medio de clavo / tornillo (no incluydo) de un panel Mitesco.

Einfache Befestigung aus Technopolymer für die Wandmontage mittels Nagel/Schraube (nicht inkludiert) eines Mitesco-Paneels.

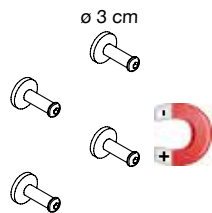

ø 3 cm

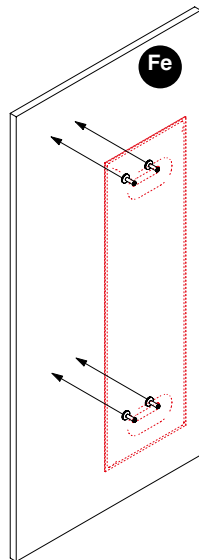

75 / 119 / 159 cm

Fe = Ferro
Iron
Fer
Hierro
Eisen

**7M232**

Kit 4 magneti per il fissaggio diretto ad una superficie verticale in ferro di un pannello Mitesco.

Set of 4 magnets for direct fixing to a vertical iron surface, of 1 Mitesco panel.

Jeu de 4 aimants pour la fixation directe à une surface verticale en fer d'un panneau Mitesco.

Kit de 4 imanes para la fijacion directa à una superficie vertical de hierro de un panel Mitesco.

Set von 4 Magneten zur direkten Befestigung auf einer vertikal Eisenoberfläche, für 1 Mitesco-Paneel.

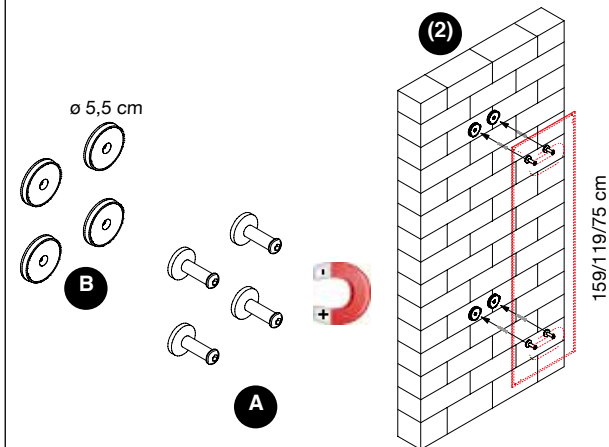
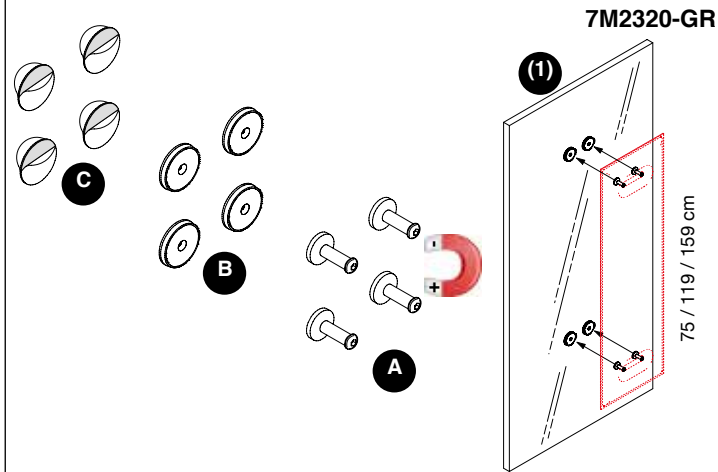

Kit per il fissaggio ad una superficie verticale in vetro o in muratura di un pannello Mitesco. Il kit è composto da: 4 magneti (A) / 4 dischi in acciaio e tecnopolimero grigio (B) / 4 dischi con biadesivo (C).

(1) Per le superfici in vetro applicare gli appositi dischetti con biadesivo (C).

(2) Per le superfici in muratura applicare direttamente i dischetti (B) tramite viti (non incluse)

Set for fixing to a glass or masonry vertical surface, of 1 Mitesco panel. Set composed of: 4 magnets (A) / 4 steel and high-tech polymer plates (B) / 4 plates with double-sided adhesive tape (C).

(1) For glass surfaces use the suitable plates with double-sided adhesive tape (C)

(2) For masonry surfaces fix directly the plates (B) with screws (not included)

Jeu pour fixation à une surface verticale en verre ou maçonnerie d'un panneau Mitesco. Le jeu se compose de: 4 aimants (A) / 4 disques en acier et technopolymère (B) / 4 disques avec bande biadhésive (C).

(1) Pour les surfaces en verre appliquer les disques par bande biadhésive (C)

(2) Pour les surfaces en maçonnerie appliquer directement les disques (B) par des vis (pas incluses)

Kit para fijación a una superficie vertical de vidrio o de mampostería de un panel Mitesco. Kit compuesto por: 4 imanes (A) / 4 discos de acero y polímero (B) / 4 discos con bi-adesivo (C).

(1) Para las superficies de vidrio aplicar los discos con su propio bi-adesivo (C)

(2) Para las superficies de mampostería aplicar directamente los discos (B) con tornillos (no incluidos)

Set zur Montage auf vertikal Glasoberflächen und Mauerwerk, für 1 Mitesco-Paneel. Set von: 4 Magneten (A) / 4 Scheiben aus Stahl und Technopolymer (B) / 4 doppelseitig klebende Scheiben (C).

(1) Für Glasoberflächen verwenden Sie die entsprechenden doppelseitig klebenden Scheiben (C)

(2) Für Mauerwerk befestigen Sie die Scheiben direkt (B) mit Schrauben (nicht inkludiert)

MAGNETIC



7M2320-GR



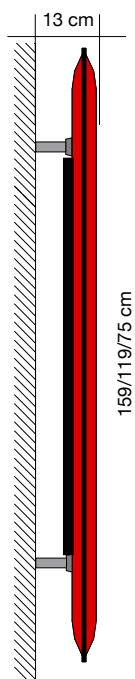
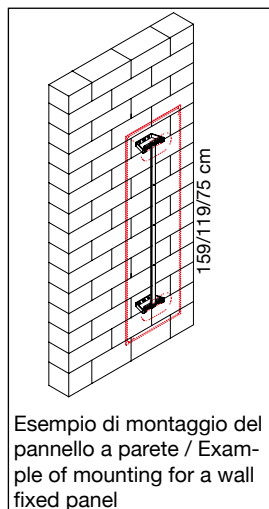
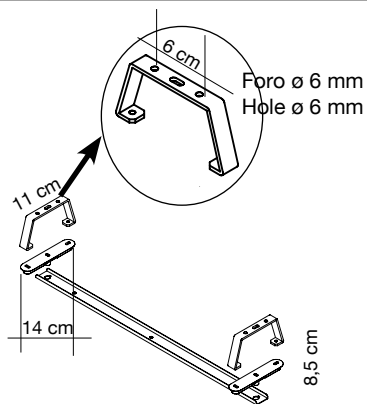

7M2476-GA Grigio argento
Silver grey
Gris argenté
Gris plata
Silbergrau

Per pannelli
For panels
L. 159 cm

Coppia attacchi distanziali in acciaio verniciato con polveri epossidiche e tecnopolimero per parete, completi di profilo livellatore per pannello Mitesco. Per montaggio a PARETE

7M2472-GA Grigio argento
Silver grey
Gris argenté
Gris plata
Silbergrau

Per pannelli
For panels
L. 119 cm

Pair of spacer connections in powder coated steel and high-tech polymer for wall, supplied with leveler profile for Mitesco panel. For WALL mounting

7M2478-GA Grigio argento
Silver grey
Gris argenté
Gris plata
Silbergrau

Per pannelli
For panels
L. 75 cm

Par de enganches espaciadores de acero recubierto epoxi y polímero para pared, incluye perfil nivelador para panel Mitesco. Para montaje en PARED

Paar Distanzhalterbefestigungen aus pulverbeschichtetem Stahl und Technopolymer zur Wandmontage, inkl. Justierprofil für Mitesco-Paneel. Für WANDMONTAGE

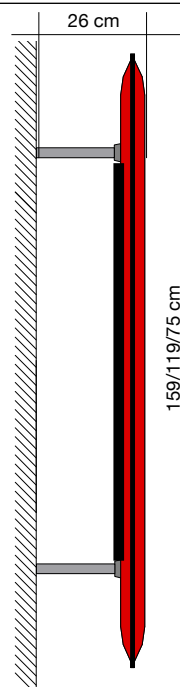
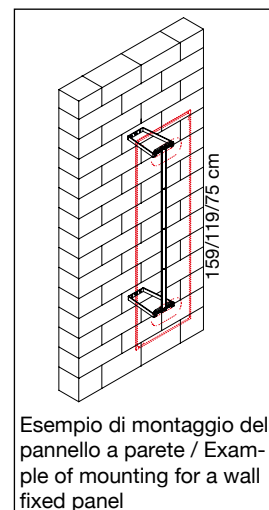
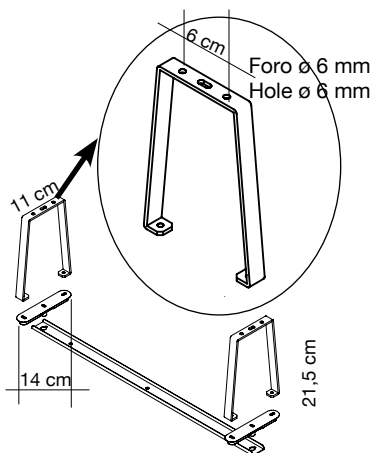

7M2426-GA Grigio argento
Silver grey
Gris argenté
Gris plata
Silbergrau

Per pannelli
For panels
L. 159 cm

Coppia attacchi distanziali in acciaio verniciato con polveri epossidiche e tecnopolimero per parete, completi di profilo livellatore per pannello Mitesco. Per montaggio a PARETE

7M2422-GA Grigio argento
Silver grey
Gris argenté
Gris plata
Silbergrau

Per pannelli
For panels
L. 119 cm

Pair of spacer connections in powder coated steel and high-tech polymer for wall, supplied with leveler profile for Mitesco panel. For WALL mounting

7M2428-GA Grigio argento
Silver grey
Gris argenté
Gris plata
Silbergrau

Per pannelli
For panels
L. 75 cm

Par de enganches espaciadores de acero recubierto epoxi y polímero para pared, incluye perfil nivelador para panel Mitesco. Para montaje en PARED

Paar Distanzhalterbefestigungen aus pulverbeschichtetem Stahl und Technopolymer zur Wandmontage, inkl. Justierprofil für Mitesco-Paneel. Für WANDMONTAGE



7M214

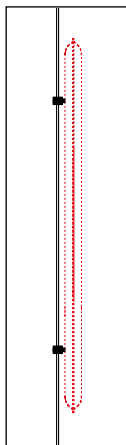
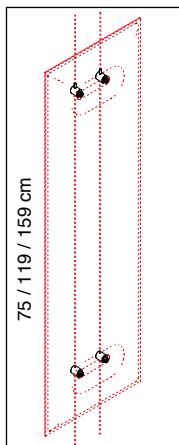
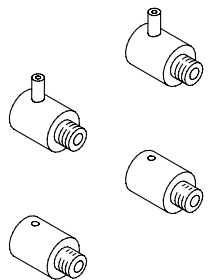

Kit 4 morsetti in metallo per cavi cod. 7M5170.
Applicabili direttamente a un pannello Mitesco.

Set of 4 steel clamps to use with cables code 7M5170
They can be applied directly to the Mitesco panel.

Jeu de 4 étaux en métal pour cables réf. 7M5170.
On peut les appliquer directement à un panneau Mitesco.

Kit de 4 sujetadores de metal para cables cod. 7M5170.
Aplicables directamente a un panel Mitesco.

Set von 4 Klemmen zur Verwendung mit Stahlseilen Art. 7M5170.
Befestigung der Klemmen direkt am Mitesco-Panel.

7M218

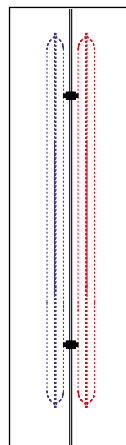
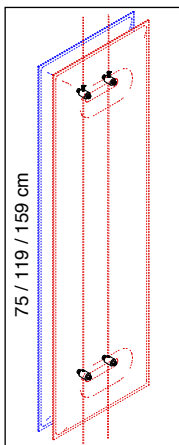
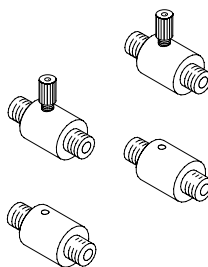

Kit 4 morsetti bifronte in metallo per cavi cod. 7M5170.
Applicabili direttamente a un pannello Mitesco.

Set of 4 double-sided steel clamps to use with cables code 7M5170
They can be applied directly to the Mitesco panel.

Jeu de 4 étaux bifronts en métal pour cables réf. 7M5170.
On peut les appliquer directement à un panneau Mitesco.

Kit de 4 sujetadores doble cara de metal para cables cod. 7M5170.
Aplicables directamente a un panel Mitesco.

Set von 4 doppelseitiger Klemmen zur Verwendung mit Stahlseilen
Art. 7M5170.
Befestigung der Klemmen direkt am Mitesco-Panel.

7M5170

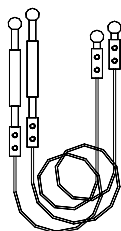

Portata massima
Maximum load

1 coppia / 1 pair
1 paire / 1 par
1 Paar

1 coppia cavi d'acciaio (4+4 m) + 1 coppia tiranti

Pair of steel cables (4+4 m) + pair of tension rods

Paire de cables en acier (4+4 m) + paire de tirants

Par de cables de acero (4+4 m) + par de pesos

1 Paar Stahlseile (4+4 m) + 1 Paar Befestigungsendstücke

	<p>7M5158-GA Grigio argento Silver grey Gris argenté Gris plata Silbergrau</p> <p>2 coppie / 2 pairs 2 paires / 2 pares 2 Paar</p> <p>1 coppia supporti in acciaio verniciato con polveri epossidiche per fissaggio a parete del cod. 7M5170. (Viti non incluse)</p> <p>1 pair of powder-coated steel supports for wall fixing of code 7M5170. (Screws not included)</p> <p>7M5158-BO Bianco opaco Mat white Blanc mat Blanco mate Mattweiß</p> <p>2 coppie / 2 pairs 2 paires / 2 pares 2 Paar</p> <p>1 paire de supports en acier peint époxy pour fixation murale de la réf. 7M5170. (Vis pas incluses)</p> <p>1 par de soportes de acero recubierto epoxi para fijación a pared para cod. 7M5170. (Tornillos no incluidos)</p> <p>1 Paar Wandbefestigungen aus pulverbeschichtetem Stahl für Art. 7M5170. (Schrauben nicht inkludiert)</p>
	<p>7M5159-GA Grigio argento Silver grey Gris argenté Gris plata Silbergrau</p> <p>2 coppie / 2 pairs 2 paires / 2 pares 2 Paar</p> <p>2 coppie in acciaio verniciato con polveri epossidiche per fissaggio a pavimento/soffitto del cod. 7M5170. (Viti non incluse)</p> <p>2 pairs of powder-coated steel supports for floor/ceiling fixing of code 7M5170. (Screws not included)</p> <p>7M5159-BO Bianco opaco Mat white Blanc mat Blanco mate Mattweiß</p> <p>2 coppie / 2 pairs 2 paires / 2 pares 2 Paar</p> <p>2 paires de supports en acier peint époxy pour fixation sol/plafond de la réf. 7M5170. (Vis pas incluses)</p> <p>2 pares de soportes de acero recubierto epoxi para fijación suelo/techo para cod. 7M5170. (Tornillos no incluidos)</p> <p>2 Paar Decken/Bodenbefestigungen aus pulverbeschichtetem Stahl für Art. 7M5170. (Schrauben nicht inkludiert)</p>
	<p>7M5140 Grigio argento Silver grey Gris argenté Gris plata Silbergrau</p> <p>1 coppia / 1 pair 1 paire / 1 pare 1 Paar</p> <p>1 coppia supporti in acciaio verniciato con polveri epossidiche per fissaggio a parete del cod. 7M5170. (Viti non incluse)</p> <p>1 pair of powder-coated steel supports for wall fixing of code 7M5170. (Screws not included)</p> <p>7M5140-BO Bianco opaco Mat white Blanc mat Blanco mate Mattweiß</p> <p>1 coppia / 1 pair 1 paire / 1 pare 1 Paar</p> <p>1 paire de supports en acier peint époxy pour fixation murale de la réf. 7M5170. (Vis pas incluses)</p> <p>1 par de soportes de acero recubierto epoxi para fijación a pared para cod. 7M5170. (Tornillos no incluidos)</p> <p>1 Paar Wandbefestigungen aus pulverbeschichtetem Stahl für Art. 7M5170. (Schrauben nicht inkludiert)</p>



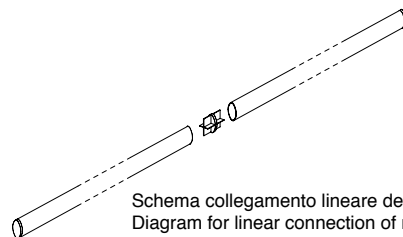
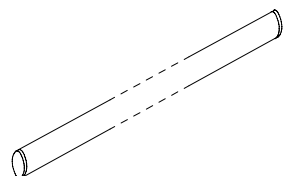
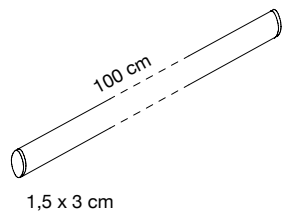

Schema collegamento lineare dei tubi
Diagram for linear connection of rails
Schéma pour la connexion linéaire des tubes
Schema de connexion linear de los tubos
Schema der gerader Stangenverbindung

7M5180

Cromato
Chrome-plated
Chromé
Cromado
Verchromt

1 coppia / 1 pair
1 paire / 1 pare
1 Paar

Coppia tubi ellittici in acciaio cromato completi di giunto per collegamento lineare.

Pair of elliptic rails in chrome-plated steel with joint for linear connection

Paire de tubes elliptiques en acier chromé avec jonction pour connexion linéaire

Par de tubos elícticos de acero cromado con enganche para enlace linear incluido

1 Paar ovale Stangen aus verchromtem Stahl mit geradem Verbindungsstück

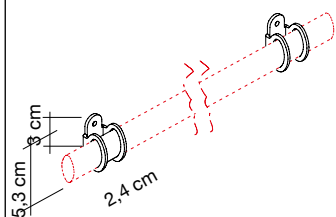
**7M5160-GA**

Grigio argento
Silver grey
Gris argenté
Gris plata
Silbergrau

2 coppie / 2 pairs
2 paires / 2 pare
2 Paar

2 coppie fissaggi a parete in acciaio verniciato con polveri epossidiche per cod. 7M5180. (Viti non incluse)

2 pairs of powder-coated steel wall connections for code 7M5180. (Screws not included)

2 paires de fixations murales en acier peint époxy pour réf. 7M5180. (Vis pas incluses)

7M5160-BO

Bianco opaco
Mat white
Blanc mat
Blanco mate
Mattweiß

2 coppie / 2 pairs
2 paires / 2 pare
2 Paar

2 pares de soportes a pared de acero recubierto epoxi para cod. 7M5180. (Tornillos no incluidos)

2 Paar Wandbefestigungen aus pulverbeschichtetem Stahl für Art.7M5180. (Schrauben nicht inkludiert)

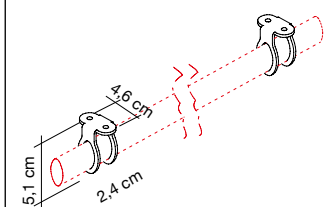
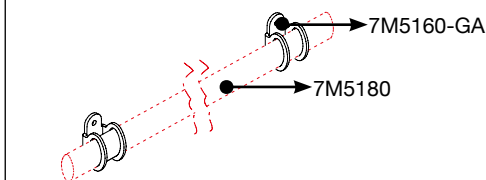
**7M5161-GA**

Grigio argento
Silver grey
Gris argenté
Gris plata
Silbergrau

2 coppie / 2 pairs
2 paires / 2 pare
2 Paar

2 coppie fissaggi a soffitto/pavimento in acciaio verniciato con polveri epossidiche per cod. 7M5180. (Viti non incluse)

2 pairs of powder-coated steel floor/ceiling connections for code 7M5180. (Screws not included)

2 paires de fixations sol/plafond en acier peint époxy pour réf. 7M5180. (Vis pas incluses)

7M5161-BO

Bianco opaco
Mat white
Blanc mat
Blanco mate
Mattweiß

2 coppie / 2 pairs
2 paires / 2 pare
2 Paar

2 pares de soportes suelo/techo de acero recubierto epoxi para cod. 7M5180. (Tornillos no incluidos)

2 Paar Decken/Bodenfestigungen aus pulverbeschichtetem Stahl für Art. 7M5180. (Schrauben nicht inkludiert)

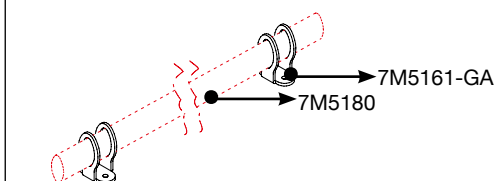

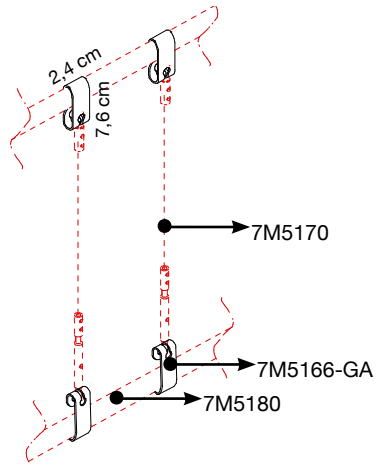

7M5166-GA

Grigio argento
Silver grey
Gris argenté
Gris plata
Silbergrau

2 coppie / 2 pairs
2 paires / 2 pare
2 Paar

2 coppie supporti in acciaio verniciato con polveri epossidiche per cod. 7M5180 e 7M5170

2 pairs of powder-coated steel supports for code 7M5180 and 7M5170

2 paires de supports en acier peint époxy pour réf. 7M5180 et 7M5170

7M5166-BO

Bianco opaco
Mat white
Blanc mat
Blanco mate
Mattweiß

2 coppie / 2 pairs
2 paires / 2 pare
2 Paar

2 pares de soportes de acero recubierto epoxi para cod. 7M5180 y 7M5170

2 Paar Befestigungshaken aus pulverbeschichtetem Stahl für Art. 7M5180 und 7M5170



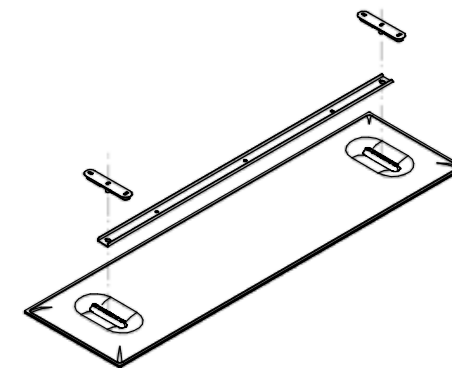
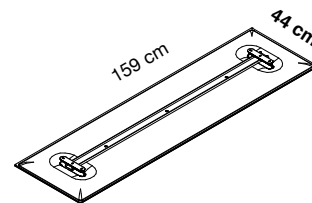
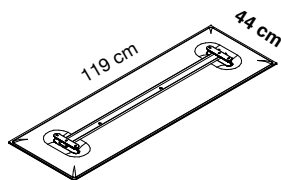
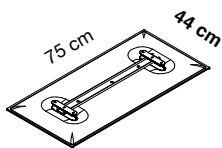

Colore Colour	Codice/Code Prezzo/Price	Codice/Code Prezzo/Price	Codice/Code Prezzo/Price	
Bianco White Blanc	0001	7MC80-0001	7MC120-0001	7MC160-0001
Grigio argento Silver grey Gris argenté	8004	7MC80-8004	7MC120-8004	7MC160-8004
Grigio scuro Dark grey Gris foncé	8007	7MC80-8007	7MC120-8007	7MC160-8007
Beige Beige Beige	1008	7MC80-1008	7MC120-1008	7MC160-1008
Tortora Dove-grey Taupe	2005	7MC80-2005	7MC120-2005	7MC160-2005
Giallo Yellow Jaune	3008	7MC80-3008	7MC120-3008	7MC160-3008
Arancione Orange Orange	4030	7MC80-4030	7MC120-4030	7MC160-4030
Rosso Red Rouge	4027	7MC80-4027	7MC120-4027	7MC160-4027
Verde chiaro Light green Vert clair	7004	7MC80-7004	7MC120-7004	7MC160-7004
Verde Green Vert	7013	7MC80-7013	7MC120-7013	7MC160-7013
Blu Blue Bleu	6071	7MC80-6071	7MC120-6071	7MC160-6071
Nero Black Noir	8033	7MC80-8033	7MC120-8033	7MC160-8033

Pannello con imbottitura interna in poliester a **densità variabile** Snowsound® Technology. Rivestimento esterno in tessuto di poliester Trevira CS®. **Completo di profilo livellatore e attacchi per fissaggio a soffitto in metallo. Coperture frontali in metallo dello stesso colore del pannello.**

Panel with polyester internal padding with Snowsound® Technology **variable density**. Polyester covering in Trevira CS® fabric. **Complete with levelling profile and metal connections for fixing to ceiling. Metal front coverings in the same color as the panel.**

Panneau avec rembourrage interne en polyester à **densité variable** Snowsound® Technology. Revêtement externe en tissu de polyester Trevira CS®. **Fourni avec profil niveleur et joints en métal pour l'installation au plafond. Caches frontales en métal dans la même couleur du panneau.**

Panel con acolchado interior de poliéster de **densidad variable** Snowsound® Technology. Revestimiento exterior de tejido de poliéster Trevira CS®. **Se completa con un perfil nivelador y fijaciones de metal para techo. Coberturas frontales de metal del mismo color del panel.**

Panel mit Polyester-Füllmaterial von **unterschiedlicher Dichte** Snowsound® Technology. Polyester-Bezug aus Trevira CS®-Material. **Deckenaufhängungs-Kit mit Nivellierprofil und Deckenbefestigungen aus Metall. Frontabdeckungen aus Metall in derselben Farbe wie den Panel.**



Foro ø 6 mm
Hole ø 6 mm

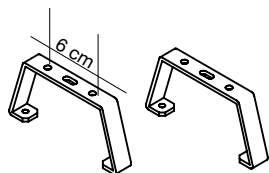

Esempio di montaggio del pannello a soffitto
Example of mounting for a ceiling fixed panel.
Da utilizzare con codici / To be used with codes:
7MC80-XXXX
7MC120-XXXX
7MC160-XXXX

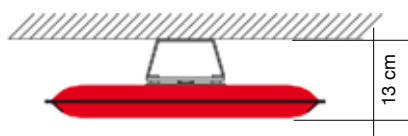

7MC247-GR

Grigio argento
Silver grey
Gris argenté
Gris plata
Silbergrau

1 coppia / 1 pair
1 paire / 1 pare
1 Paar

Coppia attacchi distanziali in acciaio verniciato con polveri epossidiche.

Per montaggio a SOFFITTO utilizzare con codici: 7MC80-XXXX - 7MC120-XXXX - 7MC160-XXXX

Pair of spacer connections in powder coated steel and high-tech polymer for ceiling.

For CEILING mounting use with codes: 7MC80-XXXX - 7MC120-XXXX - 7MC160-XXXX

Paire d'accrochages espaceurs en acier peint en époxy et technopolymère pour plafond.

Pour l'installation au plafond utiliser avec les réf.: 7MC80-XXXX - 7MC120-XXXX - 7MC160-XXXX

Par de enganches espaciadores de acero recubierto epoxi y polímero para techo.

Para montaje en TECHO usar con códigos: 7MC80-XXXX - 7MC120-XXXX - 7MC160-XXXX

Paar Distanzhalterbefestigungen aus pulverbeschichtetem Stahl und Technopolymer zur Deckenmontage.

Für DECKEN-Befestigung mit Art. 7MC80-XXXX - 7MC120-XXXX - 7MC160-XXXX benutzen.

Foro ø 6 mm
Hole ø 6 mm

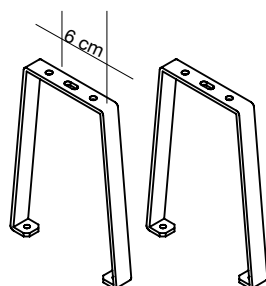

Esempio di montaggio del pannello a soffitto
Example of mounting for a ceiling fixed panel.
Da utilizzare con codici / To be used with codes:
7MC80-XXXX
7MC120-XXXX
7MC160-XXXX

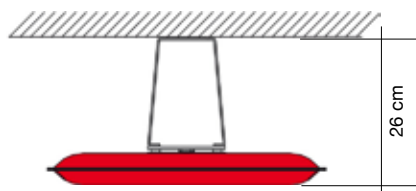

7MC242-GR

Grigio argento
Silver grey
Gris argenté
Gris plata
Silbergrau

1 coppia / 1 pair
1 paire / 1 pare
1 Paar

Coppia attacchi distanziali in acciaio verniciato con polveri epossidiche.

Per montaggio a SOFFITTO utilizzare con codici: 7MC80-XXXX - 7MC120-XXXX - 7MC160-XXXX

Pair of spacer connections in powder coated steel and high-tech polymer for ceiling.

For CEILING mounting use with codes: 7MC80-XXXX - 7MC120-XXXX - 7MC160-XXXX

Paire d'accrochages espaceurs en acier peint en époxy et technopolymère pour plafond.

Pour l'installation au plafond utiliser avec les réf.: 7MC80-XXXX - 7MC120-XXXX - 7MC160-XXXX

Par de enganches espaciadores de acero recubierto epoxi y polímero para techo.

Para montaje en TECHO usar con códigos: 7MC80-XXXX - 7MC120-XXXX - 7MC160-XXXX

Paar Distanzhalterbefestigungen aus pulverbeschichtetem Stahl und Technopolymer zur Deckenmontage.

Für DECKEN-Befestigung mit Art. 7MC80-XXXX - 7MC120-XXXX - 7MC160-XXXX benutzen.

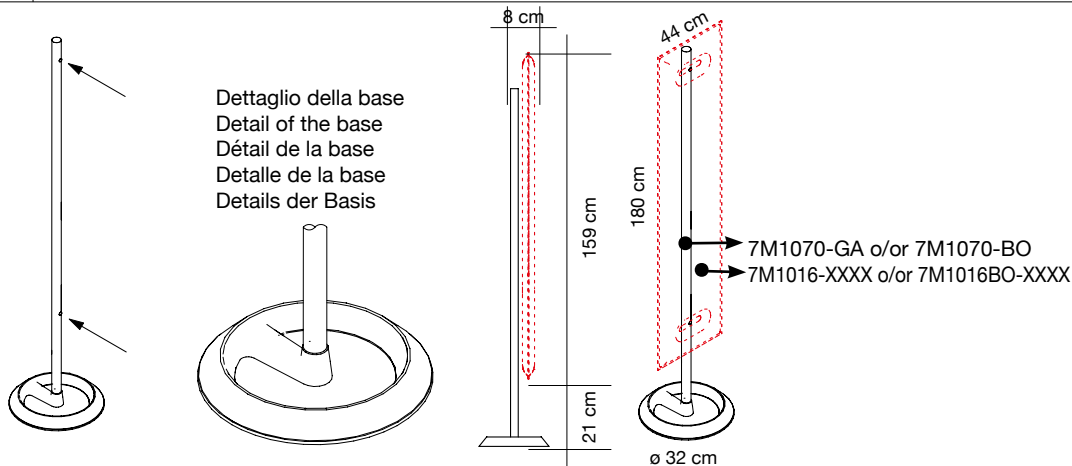
**7M1070-GA**

Grigio argento
Silver grey
Gris argenté
Gris plata
Silbergrau

7M1070-BO

Bianco opaco
Mat white
Blanc mat
Blanco mate
Mattweiß

Struttura in acciaio verniciato con polveri epossidiche con base in ghisa verniciata con polveri epossidiche per il montaggio di 1 pannello Mitesco 7M1016-XXXX, 7M1016BO-XXXX (XXXX = Variante colore).

Structure in powder-coated steel with base in powder-coated cast iron to mount 1 Mitesco panel code 7M1016-XXXX, 7M1016BO-XXXX (XXXX = Color option).

Structure en acier peint époxy avec base en fonte peinte époxy pour le montage de 1 panneau Mitesco réf. 7M1016-XXXX, 7M1016BO-XXXX (XXXX = option couleur)

Estructura de acero recubierto epoxi con base de hierro fundido recubierto epoxi para el montaje de 1 panel Mitesco 7M1016-XXXX, 7M1016BO-XXXX (XXXX = Variante color).

Standsäule aus pulverbeschichtetem Stahl mit Standfuß aus pulverbeschichtetem Gusseisen zur Aufstellung von 1 Mitesco-Paneel Art. 7M1016-XXXX, 7M1016BO-XXXX (XXXX = Farbvariante).

7M1697

Alluminio lucidato
Polished aluminium
Aluminium poli
Aluminio pulido
Poliertem Aluminium

Gancio portabiti in alluminio lucidato per strutture cod. 7M1070-GA e 7M1070-BO. **OPZIONALE**

Polished aluminium hook for structures code 7M1070-GA and 7M1070-BO. **OPTIONAL**

Crochet en aluminium poli pour structures code 7M1070-GA et 7M1070-BO. **OPTIONNEL**

Gancho en aluminio pulido para estructuras code 7M1070-GA y 7M1070-BO. **OPCIONAL**

Haken aus poliertem Aluminium für Standsäule Art. 7M1070-GA eund 7M1070-BO. **OPTIONAL erhältlich**

7M1072-GA

Grigio argento
Silver grey
Gris argenté
Gris plata
Silbergrau

7M1072-BO

Bianco opaco
Mat white
Blanc mat
Blanco mate
Mattweiß

Struttura in acciaio verniciato con polveri epossidiche con base in ghisa verniciata con polveri epossidiche per il montaggio di 2 pannelli Mitesco 7M1016-XXXX, 7M1016BO-XXXX (XXXX = Variante colore).

Structure in powder-coated steel with base in powder-coated cast iron to mount 2 Mitesco panels code 7M1016-XXXX, 7M1016BO-XXXX (XXXX = Color option).

Structure en acier peint époxy avec base en fonte peinte époxy pour le montage de 2 panneaux Mitesco réf. 7M1016-XXXX, 7M1016BO-XXXX (XXXX = option couleur)

Estructura de acero recubierto epoxi con base de hierro fundido recubierto epoxi para el montaje de 2 panels Mitesco 7M1016-XXXX, 7M1016BO-XXXX (XXXX = Variante color).

Standsäule aus pulverbeschichtetem Stahl mit Standfuß aus pulverbeschichtetem Gusseisen zur Aufstellung von 2 Mitesco-Paneel Art. 7M1016-XXXX, 7M1016BO-XXXX (XXXX = Farbvariante).

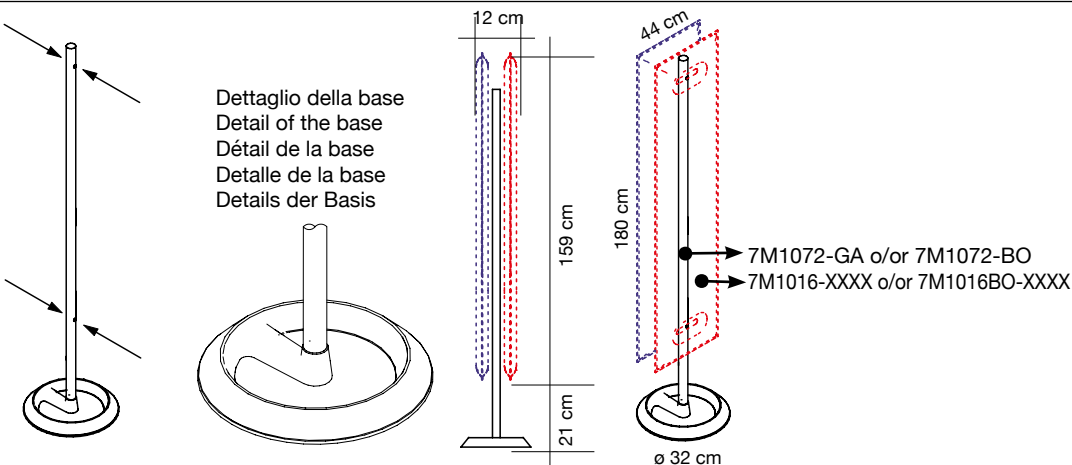
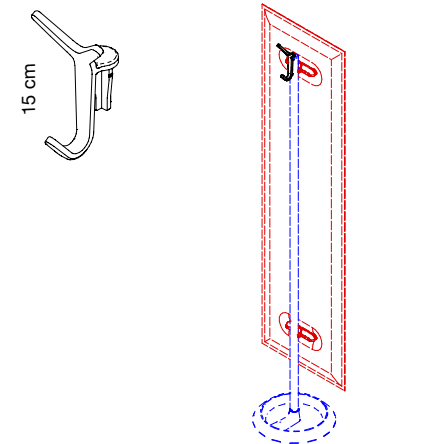





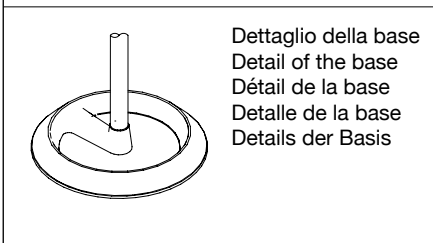

Dettaglio della base
Detail of the base
Détail de la base
Détalle de la base
Details der Basis

STRUTTURA MONOFRONTE ONE-SIDED FRAME

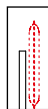

Dimension Codice/Code Prezzo/Price	Dimension Codice/Code Prezzo/Price	Dimension Codice/Code Prezzo/Price
--	--	--

Struttura in acciaio verniciato con polveri epossidiche con basi in ghisa verniciata con polveri epossidiche per il montaggio di 3 pannelli Mitesco.

Structure in powder-coated steel with bases in powder-coated cast iron to mount 3 Mitesco panels.

Structure en acier peint époxy avec bases en fonte peinte époxy pour le montage de 3 panneaux Mitesco.

Estructura de acero recubierto epoxi con bases de hierro fundido recubierto epoxi para el montaje de 3 paneles Mitesco.

Standsäulen aus pulverbeschichtetem Stahl mit Standfuß aus pulverbeschichtetem Gusseisen zur Aufstellung von 3 Mitesco-Paneelen.

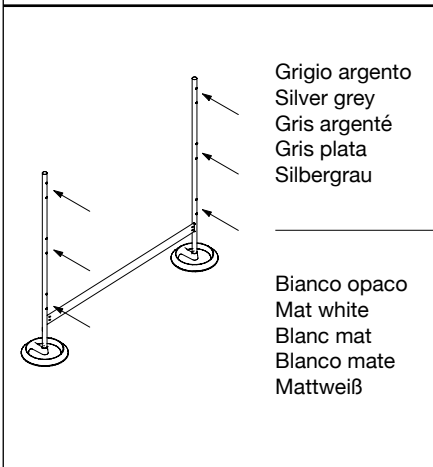

Grigio argento
Silver grey
Gris argenté
Gris plata
Silbergrau

Per pannelli For panels	Per pannelli For panels	Per pannelli For panels
L. 75 cm 7M3870-GA	L. 119 cm 7M3270-GA	L. 159 cm 7M3670-GA

Bianco opaco
Mat white
Blanc mat
Blanco mate
Mattweiß

Per pannelli For panels	Per pannelli For panels	Per pannelli For panels
L. 75 cm 7M3870-BO	L. 119 cm 7M3270-BO	L. 159 cm 7M3670-BO

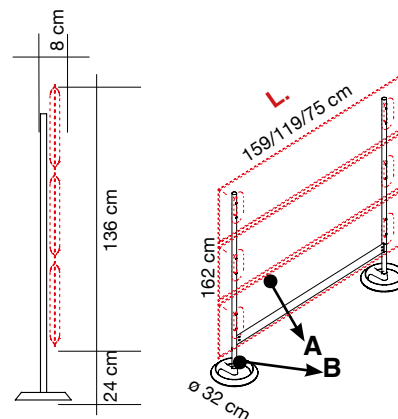

A	7M1008-XXXX o/or 7M1008BO-XXXX	L. 75 cm
B	7M3870-GA o/or 7M3870-BO	

o/or

A	7M1012-XXXX o/or 7M1012BO-XXXX	L. 119 cm
B	7M3270-GA o/or 7M3270-BO	

o/or

A	7M1016-XXXX o/or 7M1016BO-XXXX	L. 159 cm
B	7M3670-GA o/or 7M3670-BO	

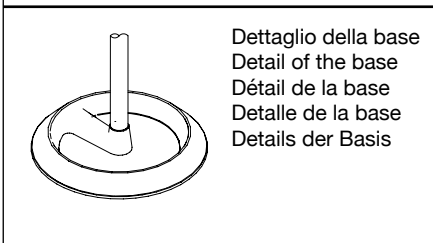

Dettaglio della base
Detail of the base
Détail de la base
Détalle de la base
Details der Basis

STRUTTURA BIFRONTE DOUBLE-SIDED FRAME

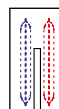

Dimension Codice/Code Prezzo/Price	Dimension Codice/Code Prezzo/Price	Dimension Codice/Code Prezzo/Price
--	--	--

Struttura in acciaio verniciato con polveri epossidiche con basi in ghisa verniciata con polveri epossidiche per il montaggio di 6 pannelli Mitesco.

Structure in powder-coated steel with bases in powder-coated cast iron to mount 6 Mitesco panels.

Structure en acier peint époxy avec bases en fonte peinte époxy pour le montage de 6 panneaux Mitesco.

Estructura de acero recubierto epoxi con bases de hierro fundido recubierto epoxi para el montaje de 6 paneles Mitesco.

Standsäulen aus pulverbeschichtetem Stahl mit Standfuß aus pulverbeschichtetem Gusseisen zur Aufstellung von 6 Mitesco-Paneelen.

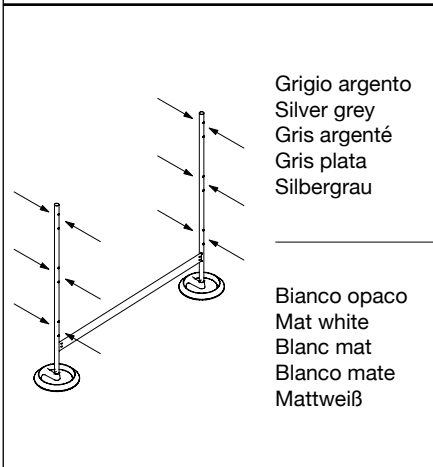

Grigio argento
Silver grey
Gris argenté
Gris plata
Silbergrau

Per pannelli For panels	Per pannelli For panels	Per pannelli For panels
L. 75 cm 7M6870-GA	L. 119 cm 7M6270-GA	L. 159 cm 7M6670-GA

Bianco opaco
Mat white
Blanc mat
Blanco mate
Mattweiß

Per pannelli For panels	Per pannelli For panels	Per pannelli For panels
L. 75 cm 7M6870-BO	L. 119 cm 7M6270-BO	L. 159 cm 7M6670-BO

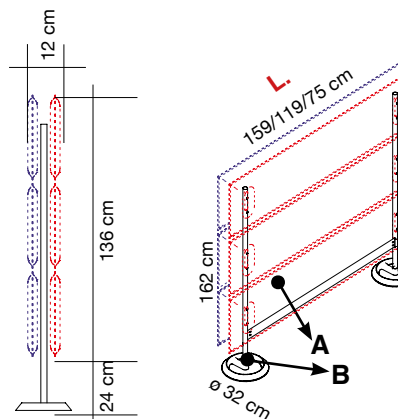

A	7M1008-XXXX o/or 7M1008BO-XXXX	L. 75 cm
B	7M6870-GA o/or 7M6870-BO	

o/or

A	7M1012-XXXX o/or 7M1012BO-XXXX	L. 119 cm
B	7M6270-GA o/or 7M6270-BO	

o/or

A	7M1016-XXXX o/or 7M1016BO-XXXX	L. 159 cm
B	7M6670-GA o/or 7M6670-BO	

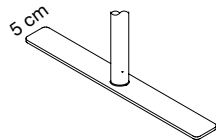

Dettaglio della base
Detail of the base
Détail de la base
Detalle de la base
Details der Basis

STRUTTURA MONOFRONTE ONE-SIDED FRAME

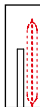

Struttura in acciaio verniciato con polveri epossidiche con basi in acciaio verniciato con polveri epossidiche per il montaggio di 2, 3 o 4 pannelli Mitesco.

Structure in powder-coated steel with bases in powder-coated steel to mount 2, 3 or 4 Mitesco panels.

Structure en acier peint époxy avec bases en acier peint époxy pour le montage de 2, 3 ou 4 panneaux Mitesco.

Estructura de acero recubierto epoxi con bases de acero recubierto epoxi para el montaje de 2, 3 o 4 paneles Mitesco.

Standsäulen aus pulverbeschichtetem Stahl mit Standfuß aus pulverbeschichtetem Stahl zur Aufstellung von 2, 3 oder 4 Mitesco-Paneelen.

Dimension Codice/Code Prezzo/Price	Dimension Codice/Code Prezzo/Price	Dimension Codice/Code Prezzo/Price
--	--	--

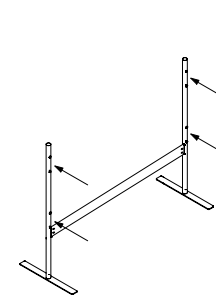

Grigio argento
Silver grey
Gris argenté
Gris plata
Silbergrau

Per pannelli For panels	Per pannelli For panels	Per pannelli For panels
L. 75 cm 7M0850-GA	L. 119 cm 7M0250-GA	L. 159 cm 7M0650-GA



Bianco opaco
Mat white
Blanc mat
Blanco mate
Mattweiß

Per pannelli For panels	Per pannelli For panels	Per pannelli For panels
L. 75 cm 7M0850-BO	L. 119 cm 7M0250-BO	L. 159 cm 7M0650-BO

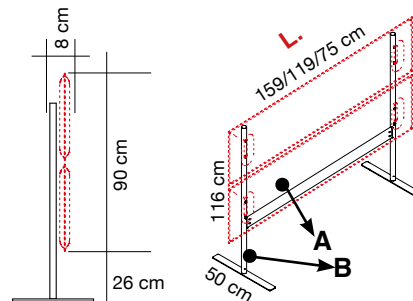

A	7M1008-XXXX o/or 7M1008BO-XXXX	L. 75 cm
B	7M0850-GA o/or 7M0850-BO	

o/or

A	7M1012-XXXX o/or 7M1012BO-XXXX	L. 119 cm
B	7M0250-GA o/or 7M0250-BO	

o/or

A	7M1016-XXXX o/or 7M1016BO-XXXX	L. 159 cm
B	7M0650-GA o/or 7M0650-BO	

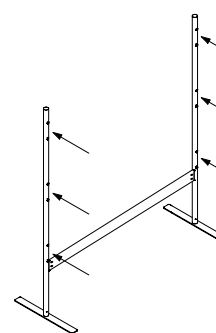

Grigio argento
Silver grey
Gris argenté
Gris plata
Silbergrau

Per pannelli For panels	Per pannelli For panels	Per pannelli For panels
L. 75 cm 7M3850-GA	L. 119 cm 7M3250-GA	L. 159 cm 7M3650-GA

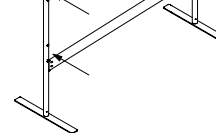

Bianco opaco
Mat white
Blanc mat
Blanco mate
Mattweiß

Per pannelli For panels	Per pannelli For panels	Per pannelli For panels
L. 75 cm 7M3850-BO	L. 119 cm 7M3250-BO	L. 159 cm 7M3650-BO

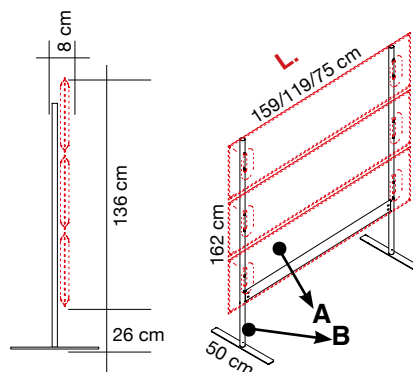

A	7M1008-XXXX o/or 7M1008BO-XXXX	L. 75 cm
B	7M3850-GA o/or 7M3850-BO	

o/or

A	7M1012-XXXX o/or 7M1012BO-XXXX	L. 119 cm
B	7M3250-GA o/or 7M3250-BO	

o/or

A	7M1016-XXXX o/or 7M1016BO-XXXX	L. 159 cm
B	7M3650-GA o/or 7M3650-BO	

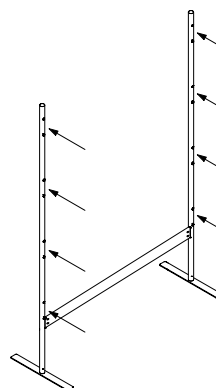

Grigio argento
Silver grey
Gris argenté
Gris plata
Silbergrau

Per pannelli For panels	Per pannelli For panels	Per pannelli For panels
L. 75 cm 7M4850-GA	L. 119 cm 7M4250-GA	L. 159 cm 7M4650-GA

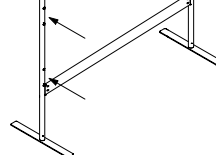

Bianco opaco
Mat white
Blanc mat
Blanco mate
Mattweiß

Per pannelli For panels	Per pannelli For panels	Per pannelli For panels
L. 75 cm 7M4850-BO	L. 119 cm 7M4250-BO	L. 159 cm 7M4650-BO

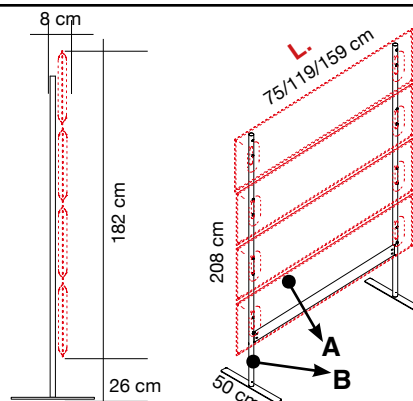

A	7M1008-XXXX o/or 7M1008BO-XXXX	L. 75 cm
B	7M4850-GA o/or 7M4850-BO	

o/or

A	7M1012-XXXX o/or 7M1012BO-XXXX	L. 119 cm
B	7M4250-GA o/or 7M4250-BO	

o/or

A	7M1016-XXXX o/or 7M1016BO-XXXX	L. 159 cm
B	7M4650-GA o/or 7M4650-BO	

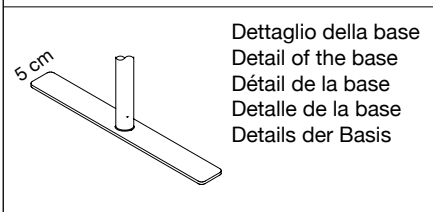

Dettaglio della base
Detail of the base
Détail de la base
Detalle de la base
Details der Basis

**STRUTTURA BIFRONTTE
DOUBLE-SIDED FRAME**

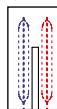

Struttura in acciaio verniciato con polveri epossidiche con basi in acciaio verniciato con polveri epossidiche per il montaggio di 4, 6 o 8 pannelli Mitesco.

Structure in powder-coated steel with bases in powder-coated steel to mount 4, 6 or 8 Mitesco panels.

Structure en acier peint époxy avec bases en acier peint époxy pour le montage de 4, 6 ou 8 panneaux Mitesco.

Estructura de acero recubierto epoxi con bases de acero recubierto epoxi para el montaje de 4, 6 o 8 paneles Mitesco.

Standsäulen aus pulverbeschichtetem Stahl mit Standfuß aus pulverbeschichtetem Stahl zur Aufstellung von 4, 6 oder 8 Mitesco-Paneelen.

Dimension Codice/Code Prezzo/Price	Dimension Codice/Code Prezzo/Price	Dimension Codice/Code Prezzo/Price
--	--	--

	Per pannelli For panels L. 75 cm 7M2850-GA	Per pannelli For panels L. 119 cm 7M2250-GA	Per pannelli For panels L. 159 cm 7M2650-GA	<table border="1"> <tr> <td>A</td> <td>7M1008-XXXX o/or 7M1008BO-XXXX</td> <td rowspan="2">L. 75 cm</td> </tr> <tr> <td>B</td> <td>7M2850-GA o/or 7M2850-BO</td> </tr> <tr> <td colspan="3" style="text-align: center;">o/or</td> </tr> <tr> <td>A</td> <td>7M1012-XXXX o/or 7M1012BO-XXXX</td> <td rowspan="2">L. 119 cm</td> </tr> <tr> <td>B</td> <td>7M2250-GA o/or 7M2250-BO</td> </tr> <tr> <td colspan="3" style="text-align: center;">o/or</td> </tr> <tr> <td>A</td> <td>7M1016-XXXX o/or 7M1016BO-XXXX</td> <td rowspan="2">L. 159 cm</td> </tr> <tr> <td>B</td> <td>7M2650-GA o/or 7M2650-BO</td> </tr> </table>	A	7M1008-XXXX o/or 7M1008BO-XXXX	L. 75 cm	B	7M2850-GA o/or 7M2850-BO	o/or			A	7M1012-XXXX o/or 7M1012BO-XXXX	L. 119 cm	B	7M2250-GA o/or 7M2250-BO	o/or			A	7M1016-XXXX o/or 7M1016BO-XXXX	L. 159 cm	B	7M2650-GA o/or 7M2650-BO
	A	7M1008-XXXX o/or 7M1008BO-XXXX	L. 75 cm																						
B	7M2850-GA o/or 7M2850-BO																								
o/or																									
A	7M1012-XXXX o/or 7M1012BO-XXXX	L. 119 cm																							
B	7M2250-GA o/or 7M2250-BO																								
o/or																									
A	7M1016-XXXX o/or 7M1016BO-XXXX	L. 159 cm																							
B	7M2650-GA o/or 7M2650-BO																								
	Per pannelli For panels L. 75 cm 7M2850-BO	Per pannelli For panels L. 119 cm 7M2250-BO	Per pannelli For panels L. 159 cm 7M2650-BO																						

	Grigio argento Silver grey Gris argenté Gris plata Silbergrau	Per pannelli For panels L. 75 cm 7M2850-GA	Per pannelli For panels L. 119 cm 7M2250-GA	Per pannelli For panels L. 159 cm 7M2650-GA	<table border="1"> <tr> <td>A</td> <td>7M1008-XXXX o/or 7M1008BO-XXXX</td> <td rowspan="2">L. 75 cm</td> </tr> <tr> <td>B</td> <td>7M2850-GA o/or 7M2850-BO</td> </tr> <tr> <td colspan="3" style="text-align: center;">o/or</td> </tr> <tr> <td>A</td> <td>7M1012-XXXX o/or 7M1012BO-XXXX</td> <td rowspan="2">L. 119 cm</td> </tr> <tr> <td>B</td> <td>7M2250-GA o/or 7M2250-BO</td> </tr> <tr> <td colspan="3" style="text-align: center;">o/or</td> </tr> <tr> <td>A</td> <td>7M1016-XXXX o/or 7M1016BO-XXXX</td> <td rowspan="2">L. 159 cm</td> </tr> <tr> <td>B</td> <td>7M2650-GA o/or 7M2650-BO</td> </tr> </table>	A	7M1008-XXXX o/or 7M1008BO-XXXX	L. 75 cm	B	7M2850-GA o/or 7M2850-BO	o/or			A	7M1012-XXXX o/or 7M1012BO-XXXX	L. 119 cm	B	7M2250-GA o/or 7M2250-BO	o/or			A	7M1016-XXXX o/or 7M1016BO-XXXX	L. 159 cm	B	7M2650-GA o/or 7M2650-BO
	A	7M1008-XXXX o/or 7M1008BO-XXXX	L. 75 cm																							
B	7M2850-GA o/or 7M2850-BO																									
o/or																										
A	7M1012-XXXX o/or 7M1012BO-XXXX	L. 119 cm																								
B	7M2250-GA o/or 7M2250-BO																									
o/or																										
A	7M1016-XXXX o/or 7M1016BO-XXXX	L. 159 cm																								
B	7M2650-GA o/or 7M2650-BO																									
	Bianco opaco Mat white Blanc mat Blanco mate Mattweiß	Per pannelli For panels L. 75 cm 7M2850-BO	Per pannelli For panels L. 119 cm 7M2250-BO	Per pannelli For panels L. 159 cm 7M2650-BO																						

	Grigio argento Silver grey Gris argenté Gris plata Silbergrau	Per pannelli For panels L. 75 cm 7M6850-GA	Per pannelli For panels L. 119 cm 7M6250-GA	Per pannelli For panels L. 159 cm 7M6650-GA	<table border="1"> <tr> <td>A</td> <td>7M1008-XXXX o/or 7M1008BO-XXXX</td> <td rowspan="2">L. 75 cm</td> </tr> <tr> <td>B</td> <td>7M6850-GA o/or 7M6850-BO</td> </tr> <tr> <td colspan="3" style="text-align: center;">o/or</td> </tr> <tr> <td>A</td> <td>7M1012-XXXX o/or 7M1012BO-XXXX</td> <td rowspan="2">L. 119 cm</td> </tr> <tr> <td>B</td> <td>7M6250-GA o/or 7M6250-BO</td> </tr> <tr> <td colspan="3" style="text-align: center;">o/or</td> </tr> <tr> <td>A</td> <td>7M1016-XXXX o/or 7M1016BO-XXXX</td> <td rowspan="2">L. 159 cm</td> </tr> <tr> <td>B</td> <td>7M6650-GA o/or 7M6650-BO</td> </tr> </table>	A	7M1008-XXXX o/or 7M1008BO-XXXX	L. 75 cm	B	7M6850-GA o/or 7M6850-BO	o/or			A	7M1012-XXXX o/or 7M1012BO-XXXX	L. 119 cm	B	7M6250-GA o/or 7M6250-BO	o/or			A	7M1016-XXXX o/or 7M1016BO-XXXX	L. 159 cm	B	7M6650-GA o/or 7M6650-BO
	A	7M1008-XXXX o/or 7M1008BO-XXXX	L. 75 cm																							
B	7M6850-GA o/or 7M6850-BO																									
o/or																										
A	7M1012-XXXX o/or 7M1012BO-XXXX	L. 119 cm																								
B	7M6250-GA o/or 7M6250-BO																									
o/or																										
A	7M1016-XXXX o/or 7M1016BO-XXXX	L. 159 cm																								
B	7M6650-GA o/or 7M6650-BO																									
	Bianco opaco Mat white Blanc mat Blanco mate Mattweiß	Per pannelli For panels L. 75 cm 7M6850-BO	Per pannelli For panels L. 119 cm 7M6250-BO	Per pannelli For panels L. 159 cm 7M6650-BO																						

	Grigio argento Silver grey Gris argenté Gris plata Silbergrau	Per pannelli For panels L. 75 cm 7M8850-GA	Per pannelli For panels L. 119 cm 7M8250-GA	Per pannelli For panels L. 159 cm 7M8650-GA	<table border="1"> <tr> <td>A</td> <td>7M1008-XXXX o/or 7M1008BO-XXXX</td> <td rowspan="2">L. 75 cm</td> </tr> <tr> <td>B</td> <td>7M8850-GA o/or 7M8850-BO</td> </tr> <tr> <td colspan="3" style="text-align: center;">o/or</td> </tr> <tr> <td>A</td> <td>7M1012-XXXX o/or 7M1012BO-XXXX</td> <td rowspan="2">L. 119 cm</td> </tr> <tr> <td>B</td> <td>7M8250-GA o/or 7M8250-BO</td> </tr> <tr> <td colspan="3" style="text-align: center;">o/or</td> </tr> <tr> <td>A</td> <td>7M1016-XXXX o/or 7M1016BO-XXXX</td> <td rowspan="2">L. 159 cm</td> </tr> <tr> <td>B</td> <td>7M8650-GA o/or 7M8650-BO</td> </tr> </table>	A	7M1008-XXXX o/or 7M1008BO-XXXX	L. 75 cm	B	7M8850-GA o/or 7M8850-BO	o/or			A	7M1012-XXXX o/or 7M1012BO-XXXX	L. 119 cm	B	7M8250-GA o/or 7M8250-BO	o/or			A	7M1016-XXXX o/or 7M1016BO-XXXX	L. 159 cm	B	7M8650-GA o/or 7M8650-BO
	A	7M1008-XXXX o/or 7M1008BO-XXXX	L. 75 cm																							
B	7M8850-GA o/or 7M8850-BO																									
o/or																										
A	7M1012-XXXX o/or 7M1012BO-XXXX	L. 119 cm																								
B	7M8250-GA o/or 7M8250-BO																									
o/or																										
A	7M1016-XXXX o/or 7M1016BO-XXXX	L. 159 cm																								
B	7M8650-GA o/or 7M8650-BO																									
	Bianco opaco Mat white Blanc mat Blanco mate Mattweiß	Per pannelli For panels L. 75 cm 7M8850-BO	Per pannelli For panels L. 119 cm 7M8250-BO	Per pannelli For panels L. 159 cm 7M8650-BO																						

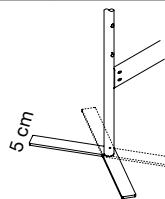

Dettaglio della base. La base può essere montata in due posizioni, interna o esterna.
Detail of the base. The base can be mounted in two positions, internal or external.

STRUTTURA MONOFRONTE ONE-SIDED FRAME

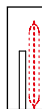

Struttura in acciaio verniciato con polveri epossidiche con basi in acciaio verniciato con polveri epossidiche per il montaggio di 2, 3 o 4 pannelli Mitesco.

Structure in powder-coated steel with bases in powder-coated steel to mount 2, 3 or 4 Mitesco panels.

Structure en acier peint époxy avec bases en acier peint époxy pour le montage de 2, 3 ou 4 panneaux Mitesco.

Estructura de acero recubierto epoxi con bases de acero recubierto epoxi para el montaje de 2, 3 o 4 paneles Mitesco.

Standsäulen aus pulverbeschichtetem Stahl mit Standfuß aus pulverbeschichtetem Stahl zur Aufstellung von 2, 3 oder 4 Mitesco-Paneele.

Dimension Codice/Code Prezzo/Price	Dimension Codice/Code Prezzo/Price	Dimension Codice/Code Prezzo/Price
--	--	--

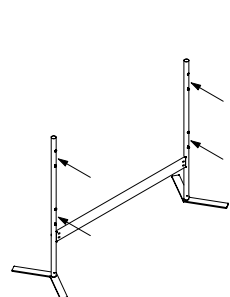

Grigio argento
Silver grey
Gris argenté
Gris plata
Silbergrau

Per pannelli For panels	Per pannelli For panels	Per pannelli For panels
L. 75 cm 7M0830-GA	L. 119 cm 7M0230-GA	L. 159 cm 7M0630-GA

Bianco opaco
Mat white
Blanc mate
Blanco mate
Mattweiß

Per pannelli For panels	Per pannelli For panels	Per pannelli For panels
L. 75 cm 7M0830-BO	L. 119 cm 7M0230-BO	L. 159 cm 7M0630-BO

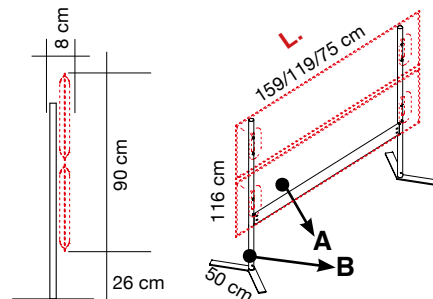

A	7M1008-XXXX o/or 7M1008BO-XXXX	L. 75 cm
B	7M0830-GA o/or 7M0830-BO	

o/or

A	7M1012-XXXX o/or 7M1012BO-XXXX	L. 119 cm
B	7M0230-GA o/or 7M0230-BO	

o/or

A	7M1016-XXXX o/or 7M1016BO-XXXX	L. 159 cm
B	7M0630-GA o/or 7M0630-BO	

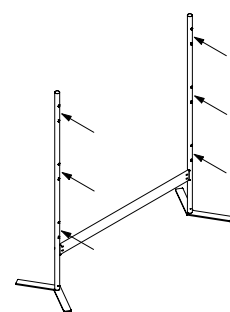

Grigio argento
Silver grey
Gris argenté
Gris plata
Silbergrau

Per pannelli For panels	Per pannelli For panels	Per pannelli For panels
L. 75 cm 7M3830-GA	L. 119 cm 7M3230-GA	L. 159 cm 7M3630-GA

Bianco opaco
Mat white
Blanc mat
Blanco mate
Mattweiß

Per pannelli For panels	Per pannelli For panels	Per pannelli For panels
L. 75 cm 7M3830-BO	L. 119 cm 7M3230-BO	L. 159 cm 7M3630-BO

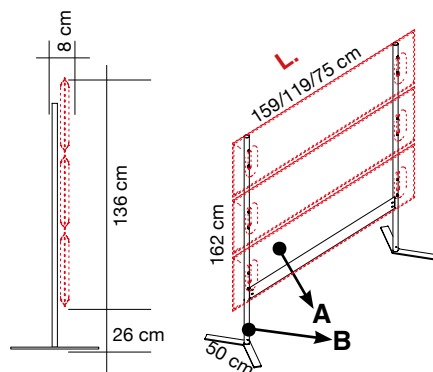

A	7M1008-XXXX o/or 7M1008BO-XXXX	L. 75 cm
B	7M3830-GA o/or 7M3830-BO	

o/or

A	7M1012-XXXX o/or 7M1012BO-XXXX	L. 119 cm
B	7M3230-GA o/or 7M3230-BO	

o/or

A	7M1016-XXXX o/or 7M1016BO-XXXX	L. 159 cm
B	7M3630-GA o/or 7M3630-BO	

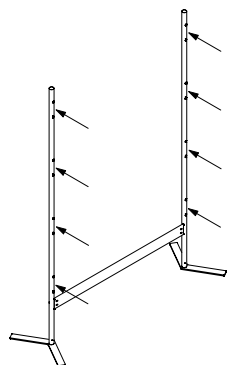

Grigio argento
Silver grey
Gris argenté
Gris plata
Silbergrau

Per pannelli For panels	Per pannelli For panels	Per pannelli For panels
L. 75 cm 7M4830-GA	L. 119 cm 7M4230-GA	L. 159 cm 7M4630-GA

Bianco opaco
Mat white
Blanc mat
Blanco mate
Mattweiß

Per pannelli For panels	Per pannelli For panels	Per pannelli For panels
L. 75 cm 7M4830-BO	L. 119 cm 7M4230-BO	L. 159 cm 7M4630-BO

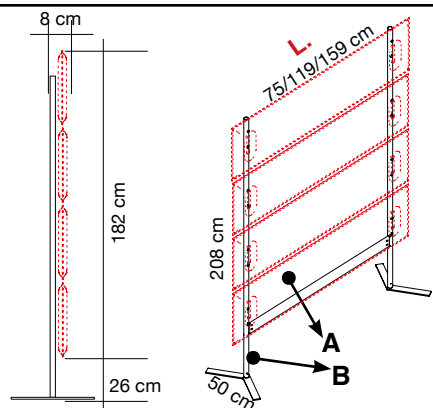

A	7M1008-XXXX o/or 7M1008BO-XXXX	L. 75 cm
B	7M4830-GA o/or 7M4830-BO	

o/or

A	7M1012-XXXX o/or 7M1012BO-XXXX	L. 119 cm
B	7M4230-GA o/or 7M4230-BO	

o/or

A	7M1016-XXXX o/or 7M1016BO-XXXX	L. 159 cm
B	7M4630-GA o/or 7M4630-BO	

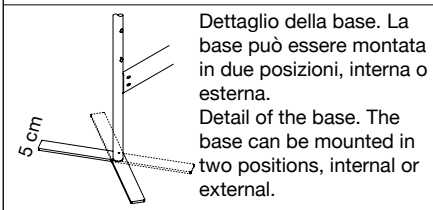

Dettaglio della base. La base può essere montata in due posizioni, interna o esterna.
Detail of the base. The base can be mounted in two positions, internal or external.

**STRUTTURA BIFRONTE
DOUBLE-SIDED FRAME**

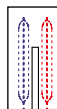

Struttura in acciaio verniciato con polveri epossidiche con basi in acciaio verniciato con polveri epossidiche per il montaggio di 4, 6 o 8 pannelli Mitesco.

Structure in powder-coated steel with bases in powder-coated steel to mount 4, 6 or 8 Mitesco panels.

Structure en acier peint époxy avec bases en acier peint époxy pour le montage de 4, 6 ou 8 panneaux Mitesco.

Estructura de acero recubierto epoxi con bases de acero recubierto epoxi para el montaje de 4, 6 o 8 paneles Mitesco.

Standsäulen aus pulverbeschichtetem Stahl mit Standfuß aus pulverbeschichtetem Stahl zur Aufstellung von 4, 6 oder 8 Mitesco-Paneelen.

Dimension Codice/Code Prezzo/Price	Dimension Codice/Code Prezzo/Price	Dimension Codice/Code Prezzo/Price
--	--	--

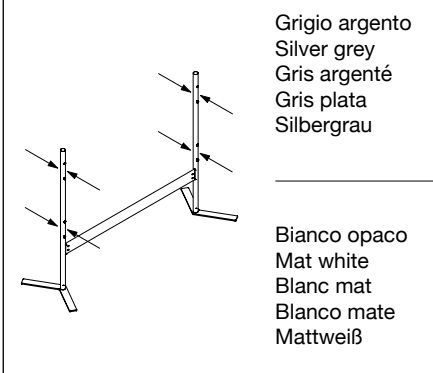

Grigio argento
Silver grey
Gris argenté
Gris plata
Silbergrau

Bianco opaco
Mat white
Blanc mat
Blanco mate
Mattweiß

Per pannelli For panels	Per pannelli For panels	Per pannelli For panels
L. 75 cm 7M2830-GA	L. 119 cm 7M2230-GA	L. 159 cm 7M2630-GA
L. 75 cm 7M2830-BO	L. 119 cm 7M2230-BO	L. 159 cm 7M2630-BO

A	7M1008-XXXX o/or 7M1008BO-XXXX	L. 75 cm
B	7M2830-GA o/or 7M2830-BO	
o/or		
A	7M1012-XXXX o/or 7M1012BO-XXXX	L. 119 cm
B	7M2230-GA o/or 7M2230-BO	
o/or		
A	7M1016-XXXX o/or 7M1016BO-XXXX	L. 159 cm
B	7M2630-GA o/or 7M2630-BO	

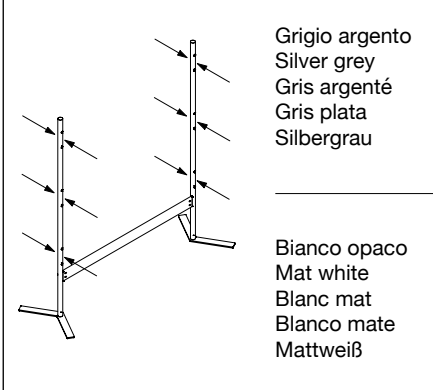

Grigio argento
Silver grey
Gris argenté
Gris plata
Silbergrau

Bianco opaco
Mat white
Blanc mat
Blanco mate
Mattweiß

Per pannelli For panels	Per pannelli For panels	Per pannelli For panels
L. 75 cm 7M6830-GA	L. 119 cm 7M6230-GA	L. 159 cm 7M6630-GA
L. 75 cm 7M6830-BO	L. 119 cm 7M6230-BO	L. 159 cm 7M6630-BO

A	7M1008-XXXX o/or 7M1008BO-XXXX	L. 75 cm
B	7M6830-GA o/or 7M6830-BO	
o/or		
A	7M1012-XXXX o/or 7M1012BO-XXXX	L. 119 cm
B	7M6230-GA o/or 7M6230-BO	
o/or		
A	7M1016-XXXX o/or 7M1016BO-XXXX	L. 159 cm
B	7M6630-GA o/or 7M6630-BO	

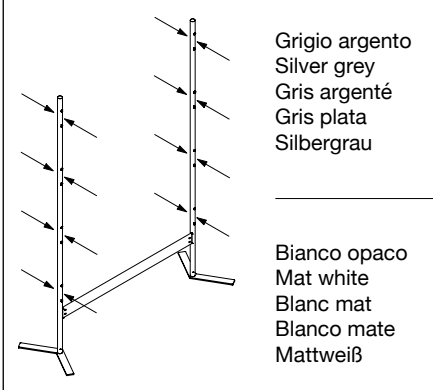

Grigio argento
Silver grey
Gris argenté
Gris plata
Silbergrau

Bianco opaco
Mat white
Blanc mat
Blanco mate
Mattweiß

Per pannelli For panels	Per pannelli For panels	Per pannelli For panels
L. 75 cm 7M8830-GA	L. 119 cm 7M8230-GA	L. 159 cm 7M8630-GA
L. 75 cm 7M8830-BO	L. 119 cm 7M8230-BO	L. 159 cm 7M8630-BO

A	7M1008-XXXX o/or 7M1008BO-XXXX	L. 75 cm
B	7M8830-GA o/or 7M8830-BO	
o/or		
A	7M1012-XXXX o/or 7M1012BO-XXXX	L. 119 cm
B	7M8230-GA o/or 7M8230-BO	
o/or		
A	7M1016-XXXX o/or 7M1016BO-XXXX	L. 159 cm
B	7M8630-GA o/or 7M8630-BO	

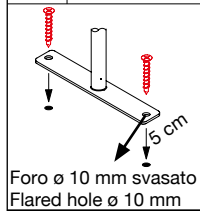

Dettaglio della base (viti non incluse) / Detail of the base (screws not included)
Détail de la base (vis pas incluses) / Detalle de la base (tornillos no incluidos) / Details der Basis (Schrauben nicht inkludiert)

STRUTTURA MONOFRONTE ONE-SIDED FRAME



Struttura in acciaio verniciato con polveri epossidiche con basi in acciaio verniciato con polveri epossidiche per il montaggio di 2, 3 o 4 pannelli Mitesco.

Structure in powder-coated steel with bases in powder-coated steel to mount 2, 3 or 4 Mitesco panels.

Structure en acier peint époxy avec bases en acier peint époxy pour le montage de 2, 3 ou 4 panneaux Mitesco.

Estructura de acero recubierto epoxi con bases de acero recubierto epoxi para el montaje de 2, 3 o 4 paneles Mitesco.

Standsäulen aus pulverbeschichtetem Stahl mit Standfuß aus pulverbeschichtetem Stahl zur Aufstellung von 2, 3 oder 4 Mitesco-Paneele.

Dimension Codice/Code Prezzo/Price	Dimension Codice/Code Prezzo/Price	Dimension Codice/Code Prezzo/Price
--	--	--

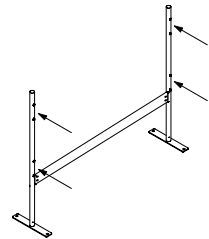

Grigio argento
Silver grey
Gris argenté
Gris plata
Silbergrau

Per pannelli
For panels
L. 75 cm
7M0825-GA

Per pannelli
For panels
L. 119 cm
7M0225-GA

Per pannelli
For panels
L. 159 cm
7M0625-GA

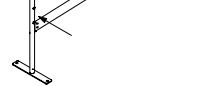

Bianco opaco
Mat white
Blanc mat
Blanco mate
Mattweiß

Per pannelli
For panels
L. 75 cm
7M0825-BO

Per pannelli
For panels
L. 119 cm
7M0225-BO

Per pannelli
For panels
L. 159 cm
7M0625-BO

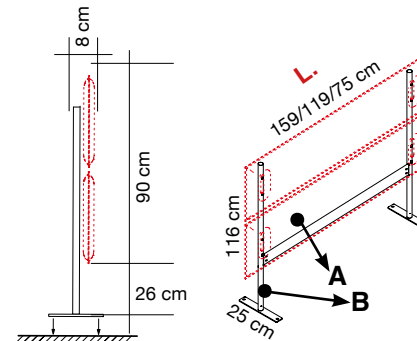

A	7M1008-XXXX o/or 7M1008BO-XXXX	L. 75 cm
B	7M0825-GA o/or 7M0825-BO	

o/or

A	7M1012-XXXX o/or 7M1012BO-XXXX	L. 119 cm
B	7M0225-GA o/or 7M0225-BO	

o/or

A	7M1016-XXXX o/or 7M1016BO-XXXX	L. 159 cm
B	7M0625-GA o/or 7M0625-BO	

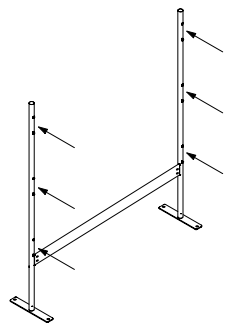

Grigio argento
Silver grey
Gris argenté
Gris plata
Silbergrau

Per pannelli
For panels
L. 75 cm
7M3825-GA

Per pannelli
For panels
L. 119 cm
7M3225-GA

Per pannelli
For panels
L. 159 cm
7M3625-GA

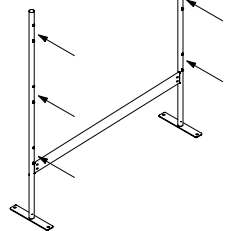

Bianco opaco
Mat white
Blanc mat
Blanco mate
Mattweiß

Per pannelli
For panels
L. 75 cm
7M3825-BO

Per pannelli
For panels
L. 119 cm
7M3225-BO

Per pannelli
For panels
L. 159 cm
7M3625-BO

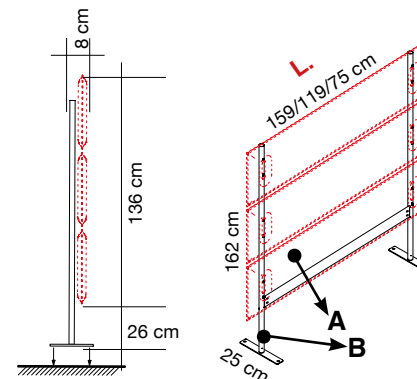

A	7M1008-XXXX o/or 7M1008BO-XXXX	L. 75 cm
B	7M3825-GA o/or 7M3825-BO	

o/or

A	7M1012-XXXX o/or 7M1012BO-XXXX	L. 119 cm
B	7M3225-GA o/or 7M3225-BO	

o/or

A	7M1016-XXXX o/or 7M1016BO-XXXX	L. 159 cm
B	7M3625-GA o/or 7M3625-BO	

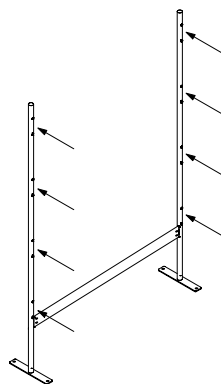

Grigio argento
Silver grey
Gris argenté
Gris plata
Silbergrau

Per pannelli
For panels
L. 75 cm
7M4825-GA

Per pannelli
For panels
L. 119 cm
7M4225-GA

Per pannelli
For panels
L. 159 cm
7M4625-GA

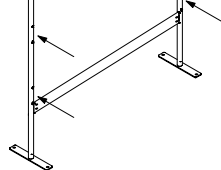

Bianco opaco
Mat white
Blanc mat
Blanco mate
Mattweiß

Per pannelli
For panels
L. 75 cm
7M4825-BO

Per pannelli
For panels
L. 119 cm
7M4225-BO

Per pannelli
For panels
L. 159 cm
7M4625-BO

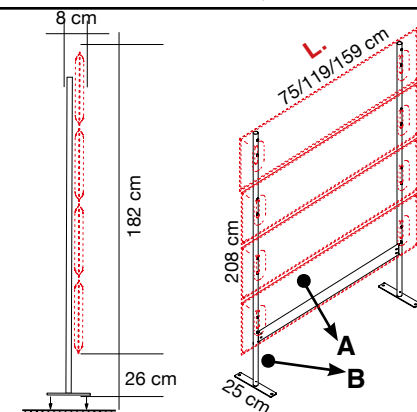

A	7M1008-XXXX o/or 7M1008BO-XXXX	L. 75 cm
B	7M4825-GA o/or 7M4825-BO	

o/or

A	7M1012-XXXX o/or 7M1012BO-XXXX	L. 119 cm
B	7M4225-GA o/or 7M4225-BO	

o/or

A	7M1016-XXXX o/or 7M1016BO-XXXX	L. 159 cm
B	7M4625-GA o/or 7M4625-BO	

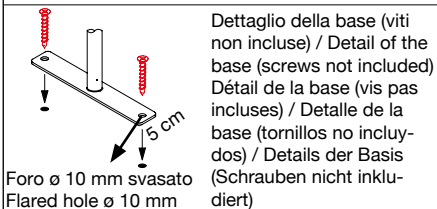

**STRUTTURA BIFRONTE
DOUBLE-SIDED FRAME**

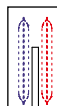

Struttura in acciaio verniciato con polveri epossidiche con basi in acciaio verniciato con polveri epossidiche per il montaggio di 4, 6 o 8 pannelli Mitesco.

Structure in powder-coated steel with bases in powder-coated steel to mount 4, 6 or 8 Mitesco panels.

Structure en acier peint époxy avec bases en acier peint époxy pour le montage de 4, 6 ou 8 panneaux Mitesco.

Estructura de acero recubierto epoxi con bases de acero recubierto epoxi para el montaje de 4, 6 o 8 paneles Mitesco.

Standsäulen aus pulverbeschichtetem Stahl mit Standfuß aus pulverbeschichtetem Stahl zur Aufstellung von 4, 6 oder 8 Mitesco-Paneelen.

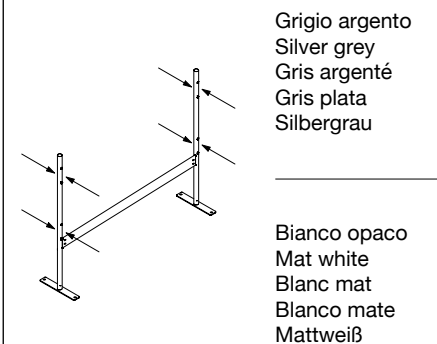

Dimension Codice/Code Prezzo/Price	Dimension Codice/Code Prezzo/Price	Dimension Codice/Code Prezzo/Price
Per pannelli For panels L. 75 cm 7M2825-GA	Per pannelli For panels L. 119 cm 7M2225-GA	Per pannelli For panels L. 159 cm 7M2625-GA
Per pannelli For panels L. 75 cm 7M2825-BO	Per pannelli For panels L. 119 cm 7M2225-BO	Per pannelli For panels L. 159 cm 7M2625-BO

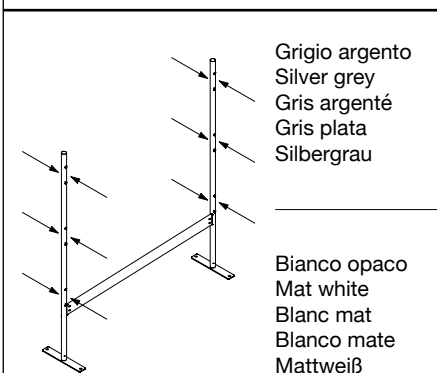
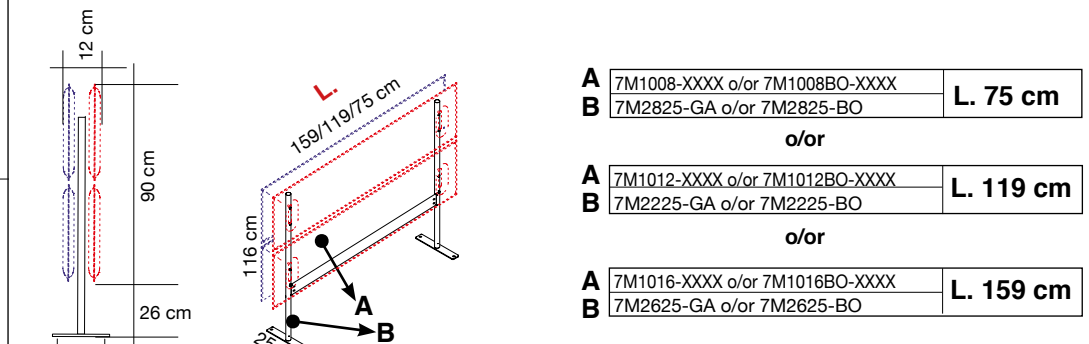

Dimension Codice/Code Prezzo/Price	Dimension Codice/Code Prezzo/Price	Dimension Codice/Code Prezzo/Price
Per pannelli For panels L. 75 cm 7M6825-GA	Per pannelli For panels L. 119 cm 7M6225-GA	Per par For pa L. 159 7M662
Per pannelli For panels L. 75 cm 7M6825-BO	Per pannelli For panels L. 119 cm 7M6225-BO	Per par For pane L. 159 cm 7M6625-BO

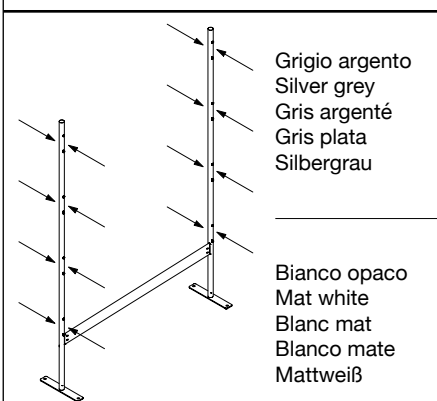
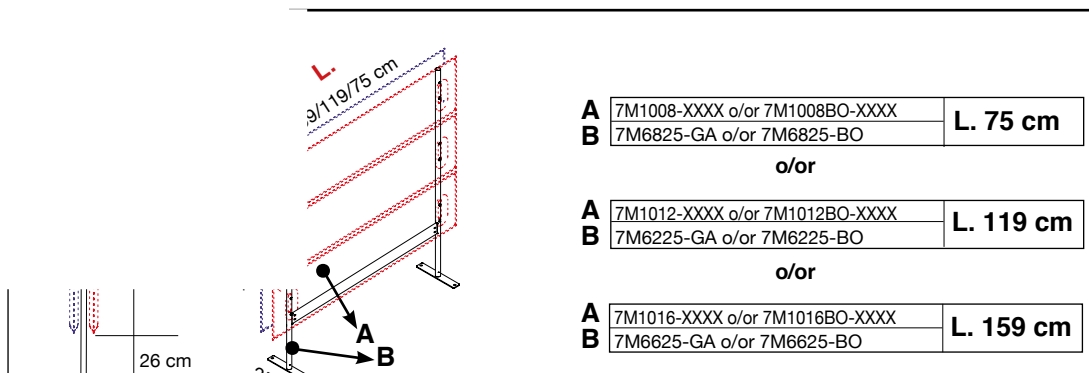

Dimension Codice/Code Prezzo/Price	Dimension Codice/Code Prezzo/Price	Dimension Codice/Code Prezzo/Price
Per pannelli For panels L. 75 cm 7M8825-GA	Per pannelli For panels L. 119 cm 7M8225-GA	Per pannelli For panels L. 159 cm 7M8625-GA
Per pannelli For panels L. 75 cm 7M8825-BO	Per pannelli For panels L. 119 cm 7M8225-BO	Per pannelli For panels L. 159 cm 7M8625-BO

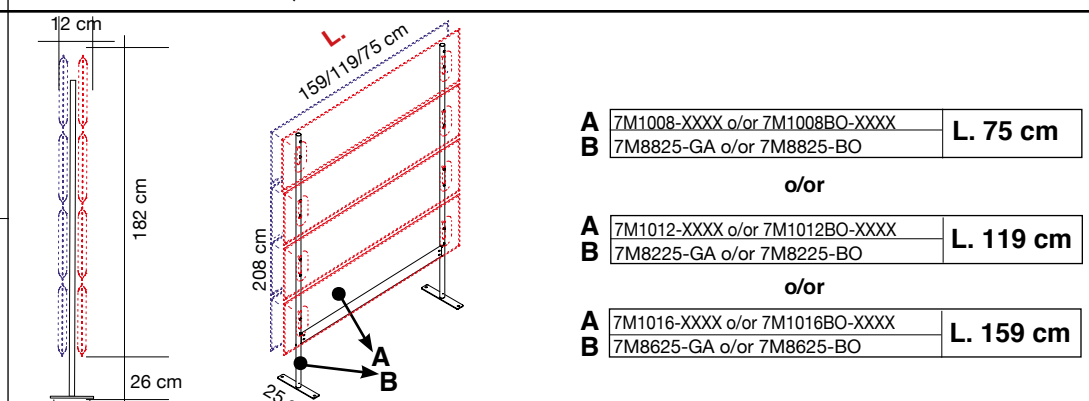

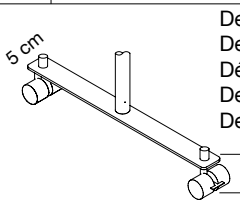

Dettaglio della base
Detail of the base
Détail de la base
Detalle de la base
Details der Basis

STRUTTURA MONOFRONTE ONE-SIDED FRAME

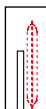

Struttura e basi in acciaio verniciato con polveri epossidiche, ruote in tecnopolimero (2 con freno e 2 senza) per il montaggio di 2, 3 o 4 pannelli Mitesco.

Frame and bases in powder-coated steel, high-tech polymer castors (2 with and 2 without brakes), to mount 2, 3 or 4 Mitesco panels.

Structure et bases acier peint époxy, roulettes technopolymère (2 avec freins et 2 sans) pour montage de 2, 3 ou 4 panneaux Mitesco.

Estructura y bases de acero recubierto epoxi, ruedas en polimero (2 con freno y 2 sin) para el montaje de 2, 3 o 4 paneles Mitesco.

Standsäulen und Standfuß aus pulverbeschichtetem Stahl, Rollen aus Technopolymer (2 davon feststellbar) zur Aufstellung von 2, 3 oder 6 Mitesco-Paneeelen.

Dimension
Codice/Code
Prezzo/Price

Dimension
Codice/Code
Prezzo/Price

Dimension
Codice/Code
Prezzo/Price

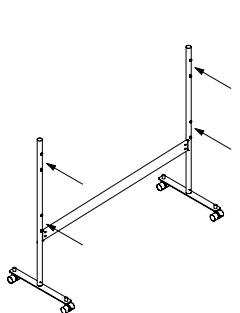

Grigio argento
Silver grey
Gris argenté
Gris plata
Silbergrau

Per pannelli
For panels
L. 75 cm
7M0860-RGA

Per pannelli
For panels
L. 119 cm
7M0260-RGA

Per pannelli
For panels
L. 159 cm
7M0660-RGA

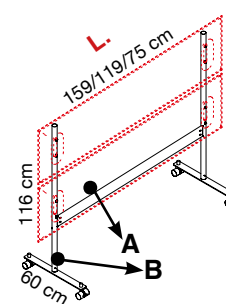
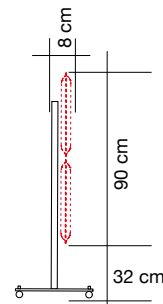

A	7M1008-XXXX o/or 7M1008BO-XXXX	L. 75 cm
B	7M0860-GA o/or 7M0860-BO	

o/or

A	7M1012-XXXX o/or 7M1012BO-XXXX	L. 119 cm
B	7M0260-GA o/or 7M0260-BO	

o/or

A	7M1016-XXXX o/or 7M1016BO-XXXX	L. 159 cm
B	7M0660-GA o/or 7M0660-BO	

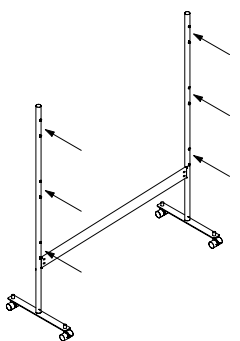

Grigio argento
Silver grey
Gris argenté
Gris plata
Silbergrau

Per pannelli
For panels
L. 75 cm
7M3860-RGA

Per pannelli
For panels
L. 119 cm
7M3260-RGA

Per pannelli
For panels
L. 159 cm
7M3660-RGA

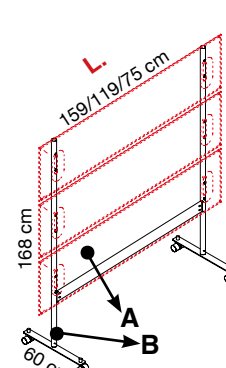
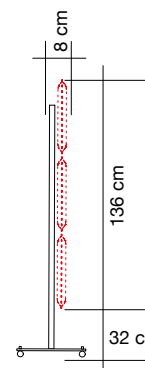

A	7M1008-XXXX o/or 7M1008BO-XXXX	L. 75 cm
B	7M3860-GA o/or 7M3860-BO	

o/or

A	7M1012-XXXX o/or 7M1012BO-XXXX	L. 119 cm
B	7M3260-GA o/or 7M3260-BO	

o/or

A	7M1016-XXXX o/or 7M1016BO-XXXX	L. 159 cm
B	7M3660-GA o/or 7M3660-BO	

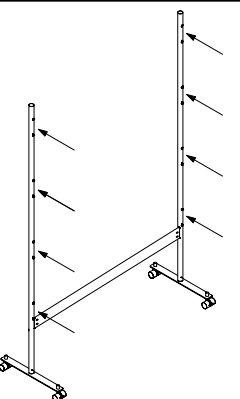

Grigio argento
Silver grey
Gris argenté
Gris plata
Silbergrau

Per pannelli
For panels
L. 75 cm
7M4860-RGA

Per pannelli
For panels
L. 119 cm
7M4260-RGA

Per pannelli
For panels
L. 159 cm
7M4660-RGA

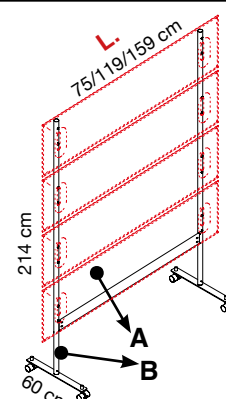
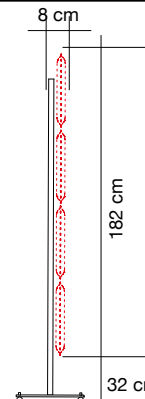

A	7M1008-XXXX o/or 7M1008BO-XXXX	L. 75 cm
B	7M4860-GA o/or 7M4860-BO	

o/or

A	7M1012-XXXX o/or 7M1012BO-XXXX	L. 119 cm
B	7M4260-GA o/or 7M4260-BO	

o/or

A	7M1016-XXXX o/or 7M1016BO-XXXX	L. 159 cm
B	7M4660-GA o/or 7M4660-BO	

Bianco opaco
Mat white
Blanc mat
Blanco mate
Mattweiß

Per pannelli
For panels
L. 75 cm
7M4860-RBO

Per pannelli
For panels
L. 119 cm
7M4260-RBO

Per pannelli
For panels
L. 159 cm
7M4660-RBO

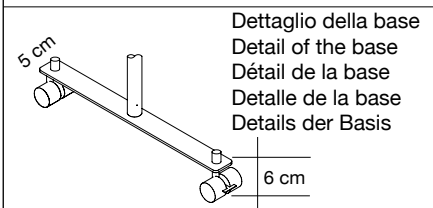

Dettaglio della base
Detail of the base
Détail de la base
Detalle de la base
Details der Basis

**STRUTTURA BIFRONTE
DOUBLE-SIDED FRAME**

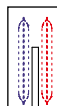

Struttura e basi in acciaio verniciato con polveri epossidiche, ruote in tecnopolimero (2 con freno e 2 senza) per il montaggio di 4, 6 o 8 pannelli Mitesco.

Frame and bases in powder-coated steel, high-tech polymer castors (2 with and 2 without brakes), to mount 4, 6 or 8 Mitesco panels.

Structure et bases acier peint époxy, roulettes technopolymère (2 avec freins et 2 sans) pour montage de 4, 6 ou 8 panneaux Mitesco.

Estructura y bases de acero recubierto epoxi, ruedas en polimero (2 con freno y 2 sin) para el montaje de 4, 6 o 8 paneles Mitesco.

Standsäulen und Standfuß aus pulverbeschichtetem Stahl, Rollen aus Technopolymer (2 davon feststellbar) zur Aufstellung von 4, 6 oder 8 Mitesco-Paneelen.

Dimension Codice/Code Prezzo/Price	Dimension Codice/Code Prezzo/Price	Dimension Codice/Code Prezzo/Price
--	--	--

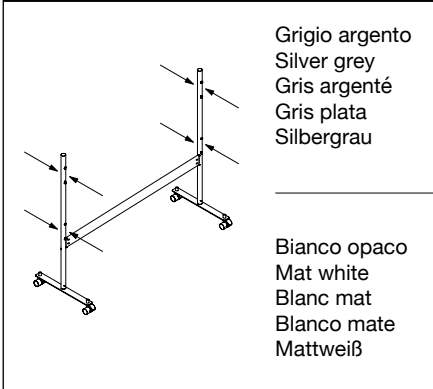

Grigio argento
Silver grey
Gris argenté
Gris plata
Silbergrau

Per pannelli For panels	Per pannelli For panels	Per pannelli For panels
L. 75 cm 7M2860-RGA	L. 119 cm 7M2260-RGA	L. 159 cm 7M2660-RGA

Bianco opaco
Mat white
Blanc mat
Blanco mate
Mattweiß

Per pannelli For panels	Per pannelli For panels	Per pannelli For panels
L. 75 cm 7M2860-RBO	L. 119 cm 7M2260-RBO	L. 159 cm 7M2660-RBO

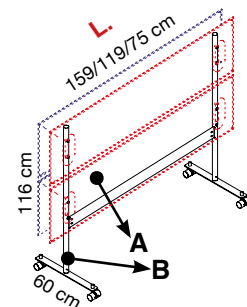
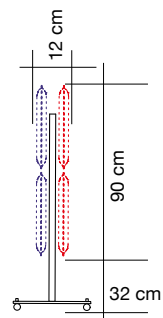

A 7M1008-XXXX o/or 7M1008BO-XXXX	L. 75 cm
B 7M2860-GA o/or 7M2860-BO	

o/or

A 7M1012-XXXX o/or 7M1012BO-XXXX	L. 119 cm
B 7M2260-GA o/or 7M2260-BO	

o/or

A 7M1016-XXXX o/or 7M1016BO-XXXX	L. 159 cm
B 7M2660-GA o/or 7M2660-BO	

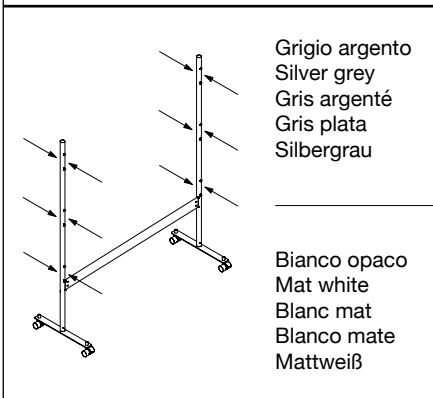

Grigio argento
Silver grey
Gris argenté
Gris plata
Silbergrau

Per pannelli For panels	Per pannelli For panels	Per pannelli For panels
L. 75 cm 7M6860-RGA	L. 119 cm 7M6260-RGA	L. 159 cm 7M6660-RGA

Bianco opaco
Mat white
Blanc mat
Blanco mate
Mattweiß

Per pannelli For panels	Per pannelli For panels	Per pannelli For panels
L. 75 cm 7M6860-RBO	L. 119 cm 7M6260-RBO	L. 159 cm 7M6660-RBO

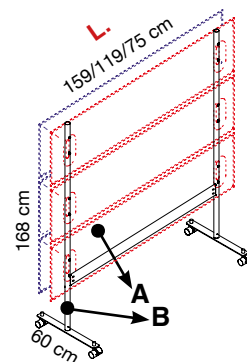
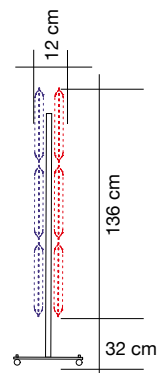

A 7M1008-XXXX o/or 7M1008BO-XXXX	L. 75 cm
B 7M6860-GA o/or 7M6860-BO	

o/or

A 7M1012-XXXX o/or 7M1012BO-XXXX	L. 119 cm
B 7M6260-GA o/or 7M6260-BO	

o/or

A 7M1016-XXXX o/or 7M1016BO-XXXX	L. 159 cm
B 7M6660-GA o/or 7M6660-BO	

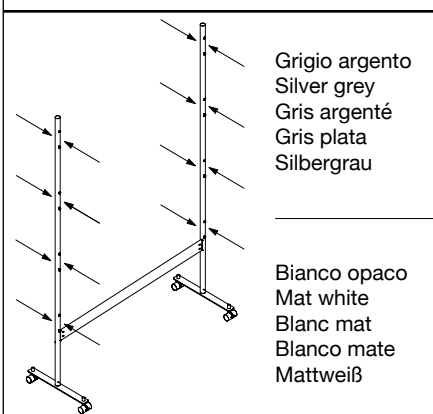

Grigio argento
Silver grey
Gris argenté
Gris plata
Silbergrau

Per pannelli For panels	Per pannelli For panels	Per pannelli For panels
L. 75 cm 7M8860-RGA	L. 119 cm 7M8260-RGA	L. 159 cm 7M8660-RGA

Bianco opaco
Mat white
Blanc mat
Blanco mate
Mattweiß

Per pannelli For panels	Per pannelli For panels	Per pannelli For panels
L. 75 cm 7M8860-RBO	L. 119 cm 7M8260-RBO	L. 159 cm 7M8660-RBO

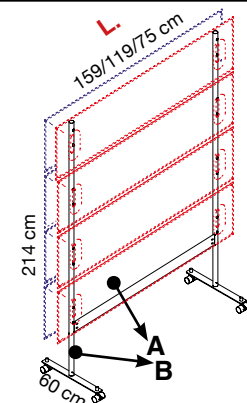
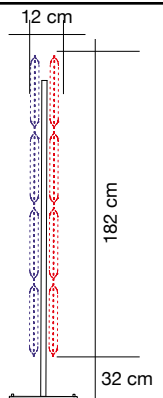

A 7M1008-XXXX o/or 7M1008BO-XXXX	L. 75 cm
B 7M8860-GA o/or 7M8860-BO	

o/or

A 7M1012-XXXX o/or 7M1012BO-XXXX	L. 119 cm
B 7M8260-GA o/or 7M8260-BO	

o/or

A 7M1016-XXXX o/or 7M1016BO-XXXX	L. 159 cm
B 7M8660-GA o/or 7M8660-BO	

FLAP

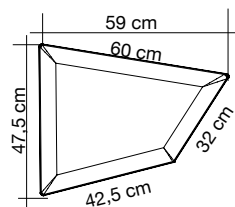
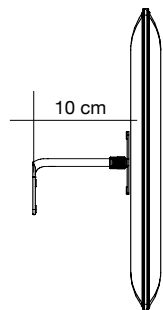

FLAP

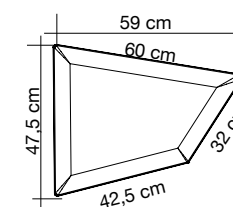
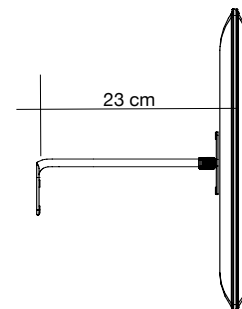



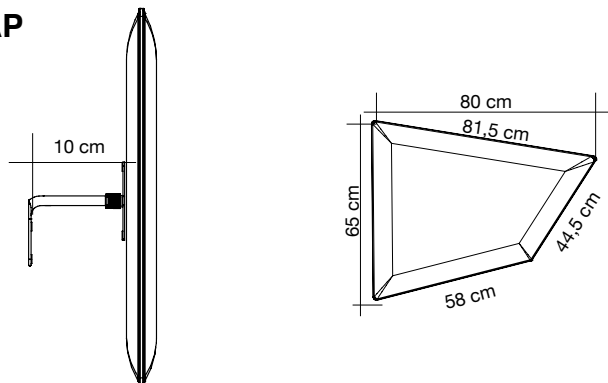

Colore Colour	Codice/Code Prezzo/Price	Colore Colour	Codice/Code Prezzo/Price	Colore Colour	Codice/Code Prezzo/Price	Colore Colour	Codice/Code Prezzo/Price
Bianco White Blanc 0001	7F1007-0001	Arancione Orange Orange 4030	7F1007-4030	Bianco White Blanc 0001	7F1020-0001	Arancione Orange Orange 4030	7F1020-4030
Grigio argento Silver grey Gris argenté 8004	7F1007-8004	Rosso Red Rouge 4027	7F1007-4027	Grigio argento Silver grey Gris argenté 8004	7F1020-8004	Rosso Red Rouge 4027	7F1020-4027
Grigio scuro Dark grey Gris foncé 8007	7F1007-8007	Verde chiaro Light green Vert clair 7004	7F1007-7004	Grigio scuro Dark grey Gris foncé 8007	7F1020-8007	Verde chiaro Light green Vert clair 7004	7F1020-7004
Beige Beige Beige 1008	7F1007-1008	Verde Green Vert 7013	7F1007-7013	Beige Beige Beige 1008	7F1020-1008	Verde Green Vert 7013	7F1020-7013
Tortora Dove-grey Taupe 2005	7F1007-2005	Blu Blue Bleu 6071	7F1007-6071	Tortora Dove-grey Taupe 2005	7F1020-2005	Blu Blue Bleu 6071	7F1020-6071
Giallo Yellow Jaune 3008	7F1007-3008	Nero Black Noir 8033	7F1007-8033	Giallo Yellow Jaune 3008	7F1020-3008	Nero Black Noir 8033	7F1020-8033

MAXIFLAP

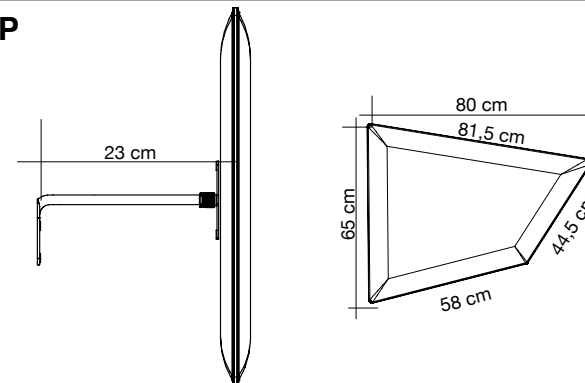

MAXIFLAP

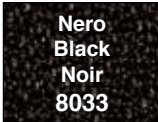

Colore Colour	Codice/Code Prezzo/Price	Colore Colour	Codice/Code Prezzo/Price	Colore Colour	Codice/Code Prezzo/Price	Colore Colour	Codice/Code Prezzo/Price
 Bianco White Blanc 0001	7F2007-0001	 Arancione Orange Orange 4030	7F2007-4030	 Bianco White Blanc 0001	7F2020-0001	 Arancione Orange Orange 4030	7F2020-4030
 Grigio argento Silver grey Gris argenté 8004	7F2007-8004	 Rosso Red Rouge 4027	7F2007-4027	 Grigio argento Silver grey Gris argenté 8004	7F2020-8004	 Rosso Red Rouge 4027	7F2020-4027
 Grigio scuro	7F2007-8007	 Verde chiaro Light green Vert clair 7004	7F2007-7004	 Grigio scuro Dark grey Gris foncé 8007	7F2020-8007	 Verde chiaro Light green Vert clair 7004	7F2020-7004
	7F2007-1008	 Verde Green Vert 7013	7F2007-7013	 Beige Beige Beige 1008	7F2020-1008	 Verde Green Vert 7013	7F2020-7013
 Tortora Dove-grey Taupe 2005	7F2007-2005	 Blu Blue Bleu 6071	7F2007-6071	 Tortora Dove-grey Taupe 2005	7F2020-2005	 Blu Blue Bleu 6071	7F2020-6071
 Giallo Yellow Jaune 3008	7F2007-3008	 Nero Black Noir 8033	7F2007-8033	 Giallo Yellow Jaune 3008	7F2020-3008	 Nero Black Noir 8033	7F2020-8033

Alcuni esempi di possibili composizioni con pannelli Flap/Maxiflap cod. 7F1007-XXXX / 7F1020-XXXX / 7F2007-XXXX e 7F2020-XXXX (XXXX = Variante colore) e relativi ingombri indicativi.

Some examples of possible compositions with panels Flap/Maxiflap cod. 7F1007-XXXX / 7F1020-XXXX / 7F2007-XXXX and 7F2020-XXXX (XXXX = Color option) and related indicative dimensions.

Quelques exemples de compositions possibles avec les panneaux Flap/Maxiflap code 7F1007-XXXX / 7F1020-XXXX / 7F2007-XXXX et 7F2020-XXXX (XXXX = option couleur) et dimensions indicatives.

Algunos ejemplos de posibles composiciones con paneles Flap/Maxiflap cod. 7F1007-XXXX / 7F1020-XXXX / 7F2007-XXXX y 7F2020-XXXX (XXXX = Variante color) y dimensiones indicativas correspondientes.

Einige Beispiele von möglichen Zusammenstellungen der Flap/Maxiflap-Paneele Art.Nr. 7F1007-XXXX / 7F1020-XXXX / 7F2007-XXXX und 7F2020-XXXX (XXXX = Farbvariante) mit den jeweiligen ungefähren Abmessungen.

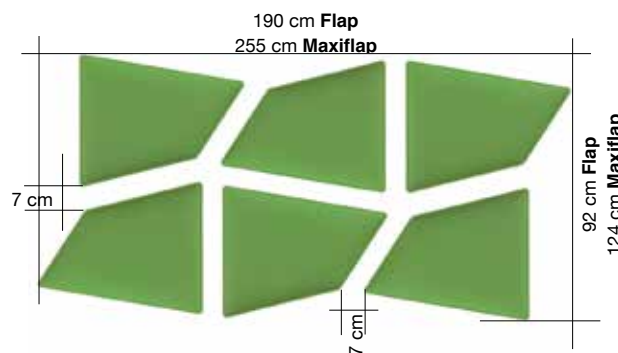
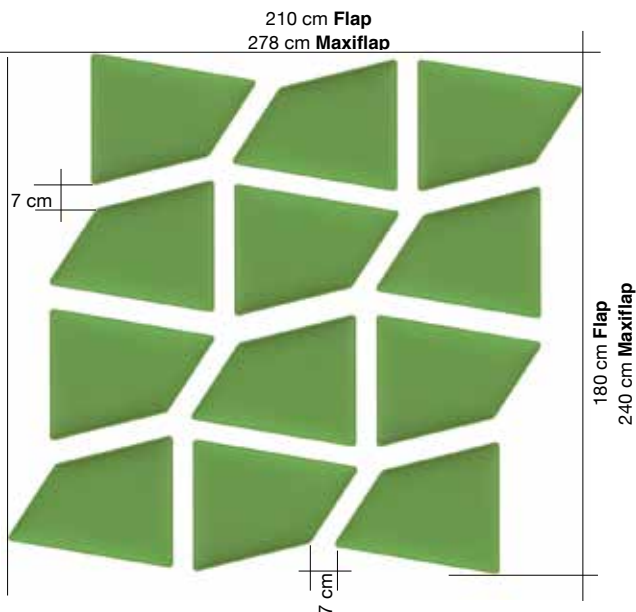
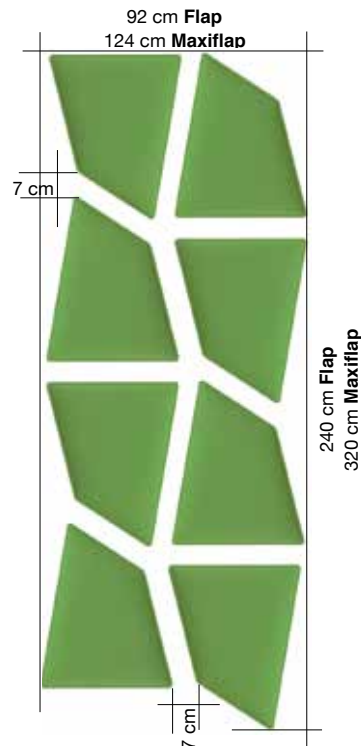
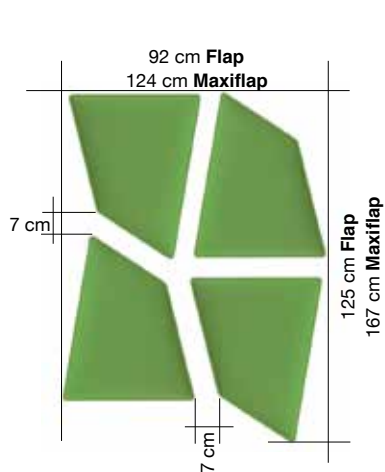

Descrizione

Description

Pannello con imbottitura interna in poliester a **densità variabile** Snowsound® Technology. Rivestimento esterno in tessuto di poliester Trevira CS®. Completo di braccio in acciaio cromato per fissaggio a parete o a soffitto (viti non incluse). Il pannello è inclinabile in tutte le direzioni e può ruotare di 360°.

Panel with polyester internal padding with Snowsound® Technology **variable density**. Polyester covering in Trevira CS® fabric. Equipped with chrome-plated steel bracket for wall or ceiling fixing (screws not included). The panel can be tilted in any direction and can rotate 360 degrees.

Panneau avec rembourrage interne en polyester à **densité variable** Snowsound® Technology. Revêtement externe en tissu de polyester Trevira CS®. Fourni avec bras en acier chromé pour fixation au mur ou au plafond (vis pas inclus). Le panneau peut être incliné dans toutes les directions et pivoter sur 360°.

Panel con acolchado interior de poliéster de **densidad variable** Snowsound® Technology. Revestimiento exterior en tejido de poliéster Trevira CS®. Completo con brazo de acero cromado para fijación a pared o al techo (tornillos no incluidos). El panel es inclinable en todas direcciones y puede rotar a 360°.

Panel mit Polyester-Füllmaterial von **unterschiedlicher Dichte** Snowsound® Technology. Polyester-Bezug aus Trevira CS®-Material. Ausgestattet mit einem Montagewinkel mit Kugelgelenk zur Befestigung an Wand oder Decke (Schrauben nicht inkludiert). Das Panel kann in jede Richtung geneigt und um 360 Grad gedreht werden.

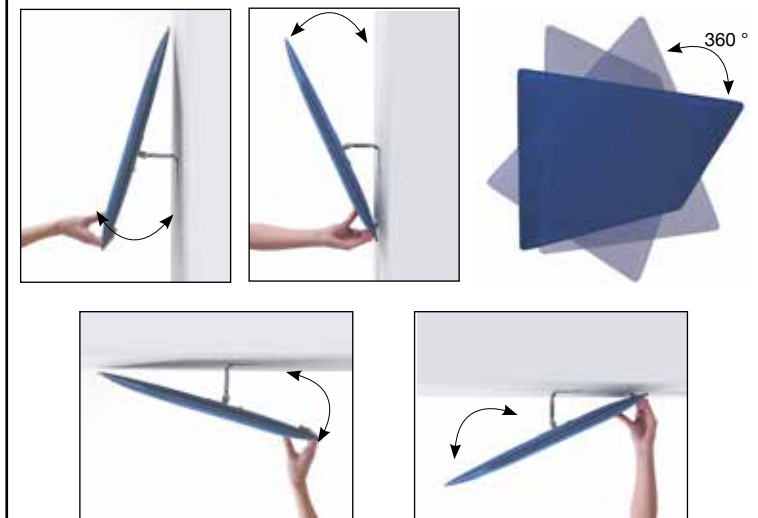

Esempio utilizzo dime fornite con i pannelli Flap/Maxiflap cod. 7F1007-XXXX / 7F1020-XXXX / 7F2007-XXXX e 7F2020-XXXX (XXXX = Variante colore).

Example for the use of templates provided with Flap/Maxiflap panels cod. 7F1007-XXXX / 7F1020-XXXX / 7F2007-XXXX and 7F2020-XXXX (XXXX = Color option).

Exemples d'utilisation modèles fournis avec les panneaux Flap/Maxiflap code 7F1007-XXXX / 7F1020-XXXX / 7F2007-XXXX et 7F2020-XXXX (XXXX = option couleur).

Ejemplo de uso de las plantillas suministradas con los paneles Flap/Maxiflap cod. 7F1007-XXXX / 7F1020-XXXX / 7F2007-XXXX y 7F2020-XXXX (XXXX = Variante color).

Beispiel für die Verwendung der mit den Flap/Maxiflap Paneelen Art.Nr. 7F1007-XXXX / 7F1020-XXXX / 7F2007-XXXX und 7F2020-XXXX (XXXX = Farbvariante) mitgelieferten Papierschablone.

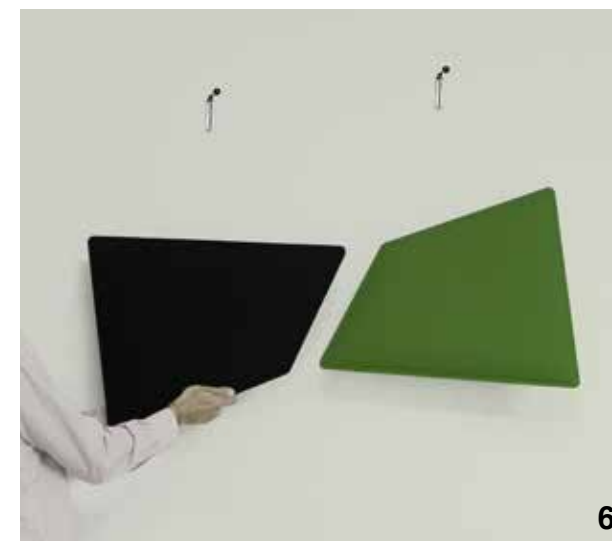
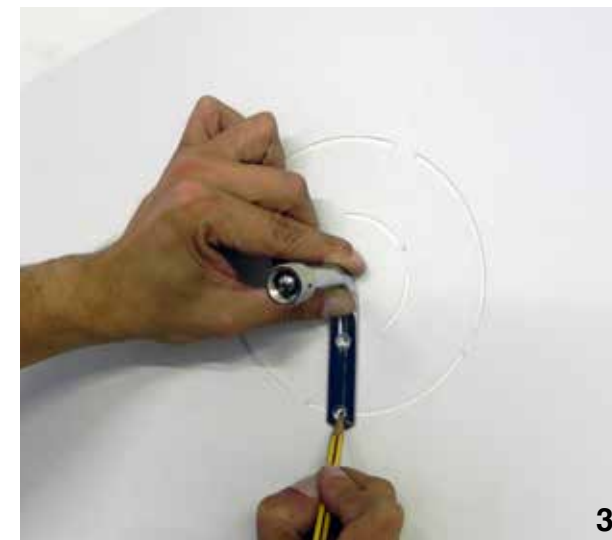
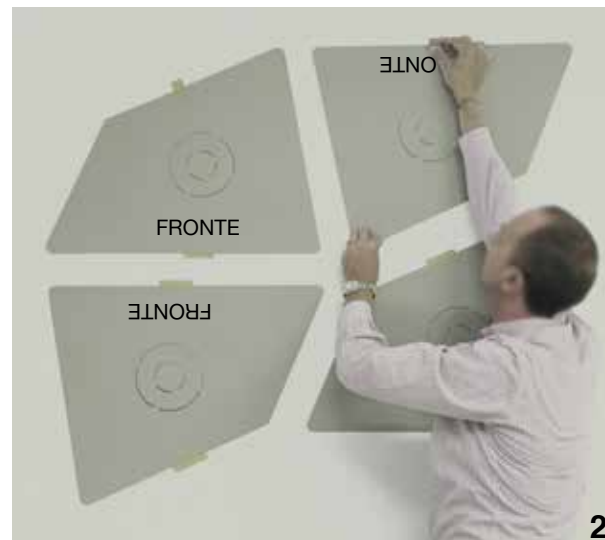

7FL110

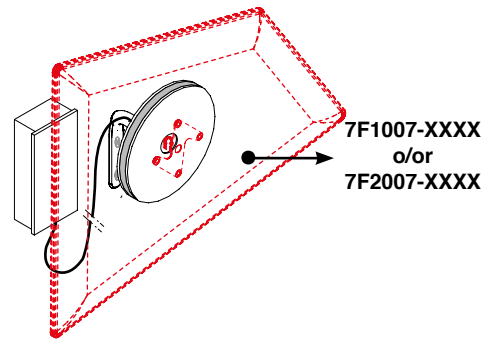
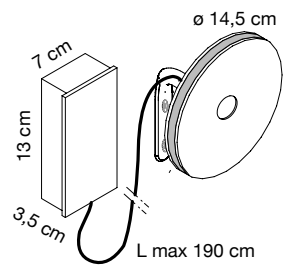

Led (6 W - 3200° K) per pannelli Flap (cod. 7F1007-XXXX) e Maxiflap (cod. 7F2007-XXXX) completo di alimentatore.

Led (6 W - 3200° K) for Flap (cod. 7F1007-XXXX) and Maxiflap (cod. 7F2007-XXXX) panels, complete with power supply.

Led (6 W - 3200° K) pour panneaux Flap (réf. 7F1007-XXXX) et Maxiflap (réf. 7F2007-XXXX) avec alimentation.

Led (6 W - 3200° K) para paneles Flap (cod. 7F1007-XXXX) y Maxiflap (cod. 7F2007-XXXX) se completa con la fuente de alimentación.

LED-Beleuchtung (6 W - 3200° K) für die Paneele Flap (Art. Nr. 7F1007-XXXX) und Maxiflap (Art. Nr. 7F2007-XXXX), inklusive Stromzufuhr.

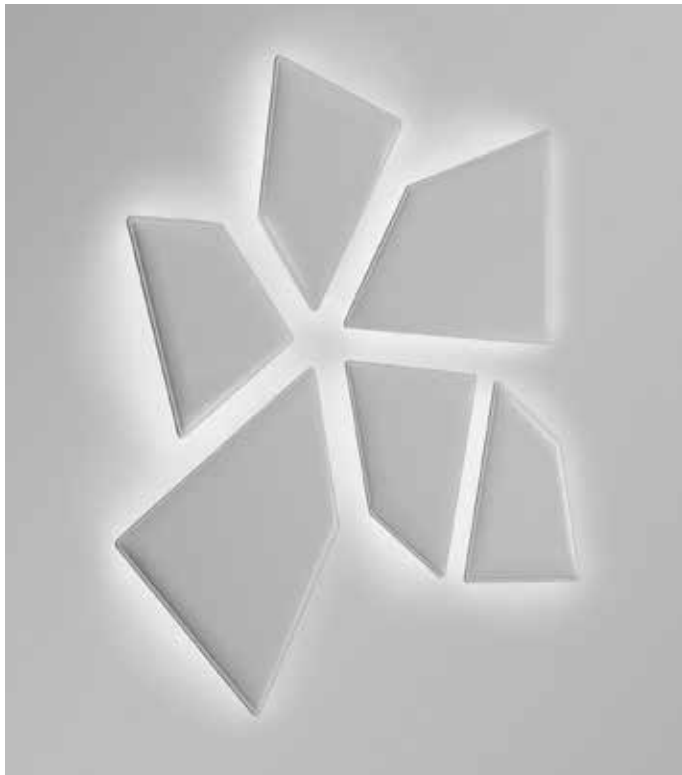

7FCL150

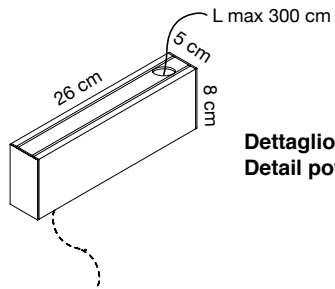
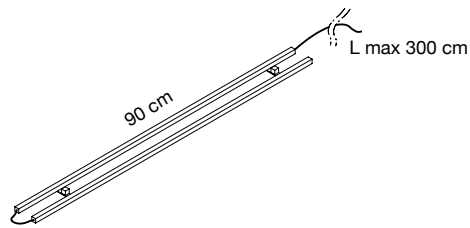

Coppia di profili con Led orientabili (2 x 25 W - 3000° K) per 1 telaio Flap cod. 7FC2024-C o 7FC1024-C + alimentatore (60 W) completo di carter di copertura in alluminio.

Pair of profiles with adjustable Led (2 x 25 W - 3000° K) for one Flap frame (product code 7FC2024-C or C-7FC1024) + Power supply (60 W) complete with aluminum cover

Paire de profils avec Led orientables (2 x 25 W - 3000° K) pour 1 structure Flap réf. 7FC2024-C ou 7FC1024-C + alimentateur (60 W) avec carter de couverture en aluminium.

Set de 2 perfiles con Led ajustables (2 x 25 W - 3000° K) para 1 estructurar Flap cod. 7FC2024-C o 7FC1024-C + unidad de alimentación (60 W) completa de carter de cobertura en aluminio.

Ein Paar Profile mit justierbaren LED (2 x 25 W - 3000° K) für eine Flap-Halterung zur Deckenmontage (Art. Nr. 7FC2024-C oder C-7FC1024) + Stromzufuhr (60 W) inklusive Abdeckung aus Aluminium.

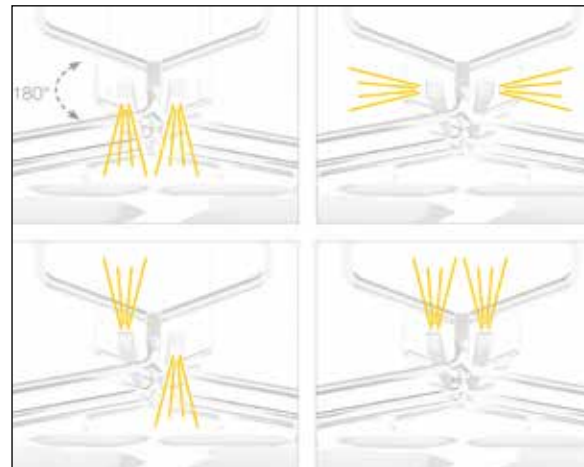
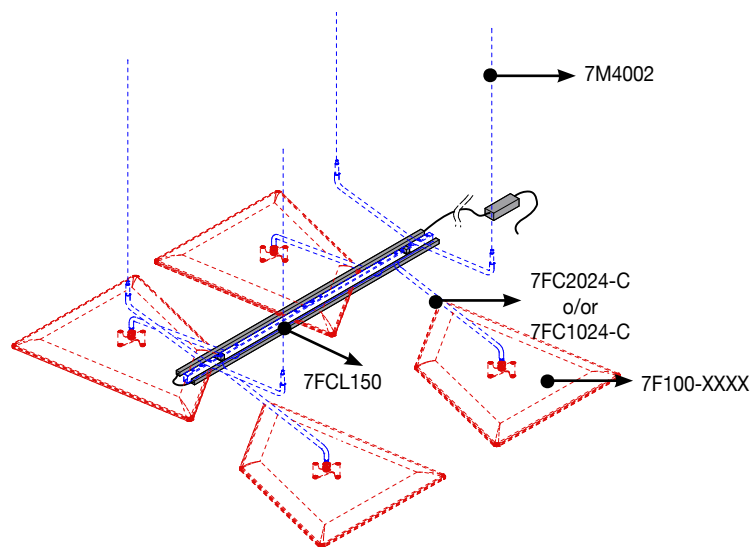

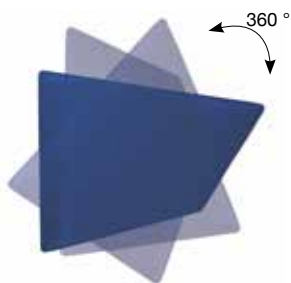
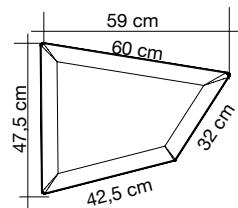
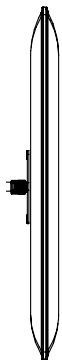

Colore Colour	Codice/Code Prezzo/Price	Colore Colour	Codice/Code Prezzo/Price
Bianco White Blanc 0001	7F100-0001	Arancione Orange Orange 4030	7F100-4030
Grigio argento Silver grey Gris argenté 8004	7F100-8004	Rosso Red Rouge 4027	7F100-4027
Grigio scuro Dark grey Gris foncé 8007	7F100-8007	Verde chiaro Light green Vert clair 7004	7F100-7004
Beige Beige Beige 1008	7F100-1008	Verde Green Vert 7013	7F100-7013
Tortora Dove-grey Taupe 2005	7F100-2005	Blu Blue Bleu 6071	7F100-6071
Giallo Yellow Jaune 3008	7F100-3008	Nero Black Noir 8033	7F100-8033

Descrizione Description

Pannello con imbottitura interna in poliester a **densità variabile** Snowsound® Technology. Rivestimento esterno in tessuto di poliester Trevira CS®. Completo di piastra e snodo in acciaio cromato per fissaggio ai telai a soffitto cod. 7FC1024-C e 7FC2024-C e ai totem cod. 7FT3006-BO e 7FT3006-N. Il pannello è inclinabile in tutte le direzioni e può ruotare di 360°.

Panel with polyester internal padding with Snowsound® Technology **variable density**. Polyester covering in Trevira CS® fabric. Equipped with plate and chrome-plated joint for fixing to frames hanging from the ceiling code 7FC1024-C and 7FC2024-C and to free-standing supports code 7FT3006-BO and 7FT3006-N. The panel can be tilted in any direction and can rotate 360 degrees.

Panneau avec rembourrage interne en polyester à **densité variable** Snowsound® Technology. Revêtement externe en tissu de polyester Trevira CS®. Fourni avec plaque et articulation en acier chromé pour la fixation des châssis au plafond code 7FC1024-C et 7FC2024-C, et aux totems code 7FT3006-BO et 7FT3006-N. Le panneau peut être incliné dans toutes les directions et pivoter sur 360°.

Panel con acolchado interior de poliéster de **densidad variable** Snowsound® Technology. Revestimiento exterior en tejido de poliéster Trevira CS®. Completo con placa y articulación de acero cromado para fijación al bastidor al techo 7FC1024-C et 7FC2024-C y a los totem FT3006-BO et 7FT3006-N. El panel es inclinable en todas direcciones y puede rotar a 360°.

Akustikpaneel, innen mit Polyester in **unterschiedlicher Dichte** unter Verwendung der Snowsound®-Technologie gepolstert. Oberfläche aus Polyesterstoff Trevira CS®. Ausgestattet mit einer Montageplatte und einem verchromten Gelenk zur Befestigung an Rahmenkonstruktionen zur Deckenabhängung Art.Nr. 7FC1024-C und 7FC2024-C bzw. zur Befestigung an Standsäulen Art.Nr. 7FT3006-BO und 7FT3006-N. Das Paneel kann in jede Richtung geneigt und um 360 Grad gedreht werden.

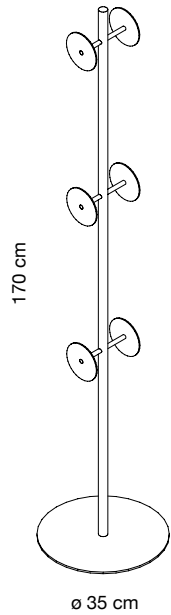

7FT3006-BO

Bianco opaco /
Cromato
Mat white /
Chrome-plated
Blanc mat /
Chromé
Blanco mate /
Cromado
Matweiß /
Verchromtem

7FT3006-N

Nero / Cromato
Black /
Chrome-plated
Noir / Chromé
Negro /
Cromado
Schwarz /
Verchromtem

Struttura in acciaio cromato con base in acciaio verniciato con polveri epossidiche colore bianco o nero per il montaggio di 6 pannelli Flap 7F100-XXXX (XXXX = Variante colore).

Structure in chrome-plated steel with mat white or black powder-coated steel base to mount 6 Flap panels code 7F100-XXXX (XXXX = Color option).

Structure en acier chromé avec base en acier peint époxy blanc mat ou noir pour l'accrochage de 6 panneaux Flap 7F100-XXXX (XXXX = option couleur)

Estructura de acero cromado con base de acero recubierto epoxi blanco mate o negro para el montaje de 6 panels Flap 7F100-XXXX (XXXX = Variante color).

Standssäule aus verchromtem Stahl mit Standfuß aus pulverbeschichtetem Stahl, matweiß oder schwarz für 6 Flap-Paneele Art. 7F100-XXXX (XXXX = Farbvariante).

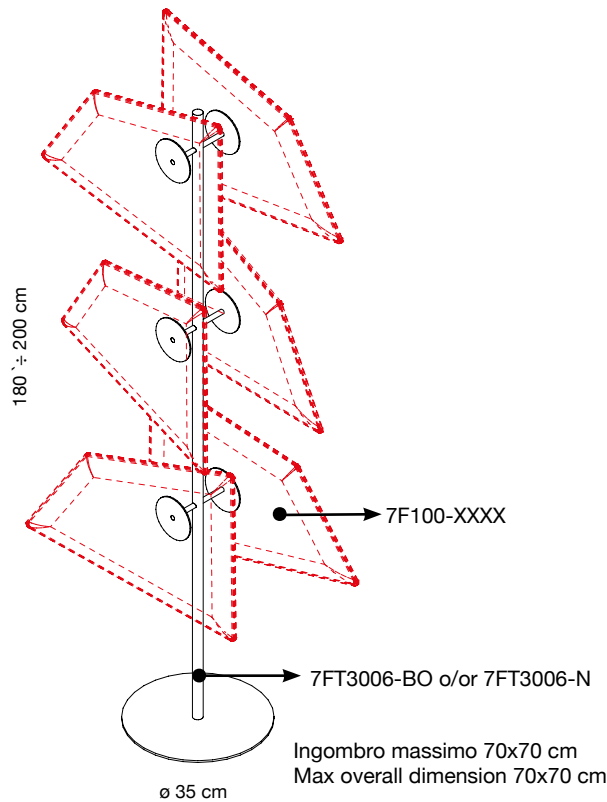

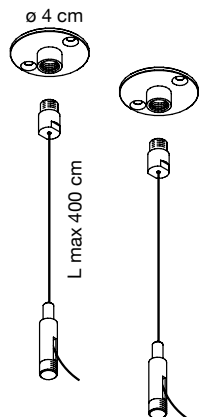
**7M4002**

Cromato
Chrome-plated
Chromé
Cromado
Verchromt

Kit per fissaggio a soffitto dei telai Flap 7FC2024-C e 7FC1024-C composto da:
2 piastre a soffitto a 2 fori - 2 cavi in acciaio - 2 attacchi a telaio

Kit for the ceiling fixing of frames Flap 7FC2024-C and 7FC1024-C composed of: 2 ceiling plates with 2 holes - 2 steel cables - 2 hangings

Kit d'accrochage au plafond pour châssis Flap 7FC2024-C et 7FC1024-C composé de:
2 platines pour plafond à 2 trous - 2 câbles en acier - 2 accrochages

Kit para el montaje al techo de bastidor Flap 7FC2024-C y 7FC1024-C compuesto por:
2 placas de techo con 2 huecos - 2 cables de acero, 2 enganches

Set für die Deckenbefestigung der netzartigen Struktur Flap 7FC2024-C und 7FC1024-C, bestehend aus:
2 Deckenmontageplatten mit 2 Befestigungsbohrungen, 2 Stahlseile, 2 Befestigungen

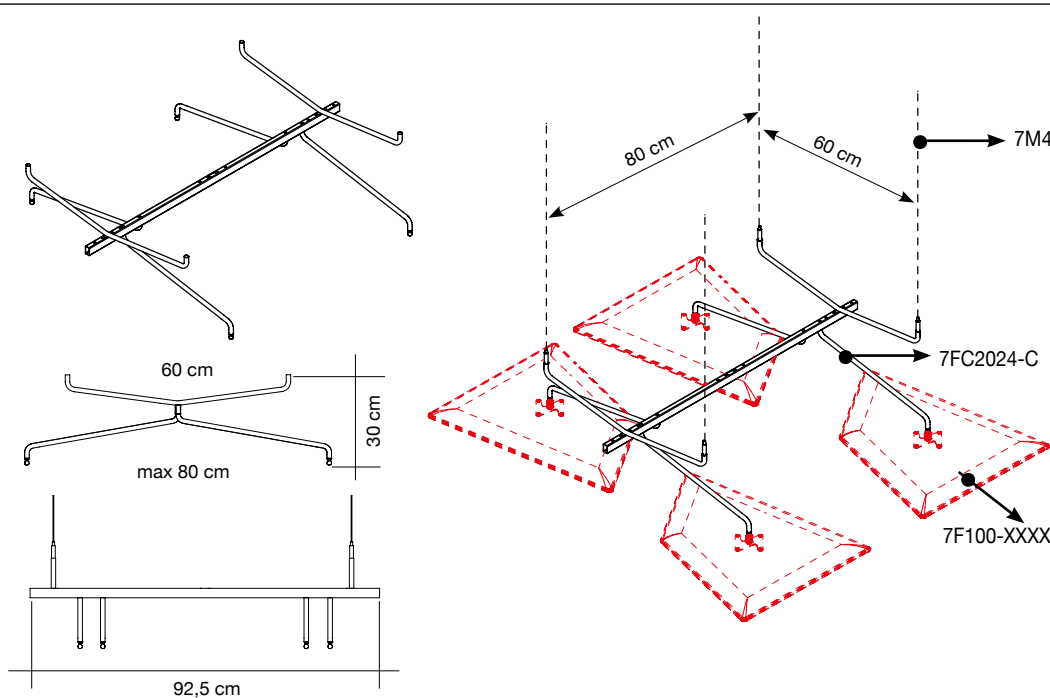
**7FC2024-C**

Cromato
Chrome-plated
Chromé
Cromado
Verchromt

Telaio in acciaio cromato per appendimento a soffitto di 4 pannelli Flap cod. 7F100-XXXX (XXXX = Variante colore).

Telaio singolo, **NON MODULARE**. Per utilizzo in composizioni singole.

Chrome-plated frame for fixing to the ceiling four Flap panels code 7F100-XXX (XXXX = Color option).
Single frame, **NOT MODULAR**. For use in single structures.

Châssis en acier chromé pour l'accrochage au plafond de 4 panneaux Flap code 7F100-XXXX (XXXX = option couleur)
Châssis simple, **NON MODULABLE**. Pour compositions simples.

Bastidor de acero cromado para fijación al techo de 4 paneles Flap cod. 7F100-XXXX (XXXX = Variante color).
Bastidor solo, **NO MODULAR**, para utilización con composiciones individuales.

Verchromte Halterung zur Deckenmontage von vier Flap Paneelen Art.Nr. 7F100-XXX (XXXX = Farbvariante).
Einzelne Halterung, **NICHT MODULAR**. Zur Verwendung in Einzelkonstruktionen.

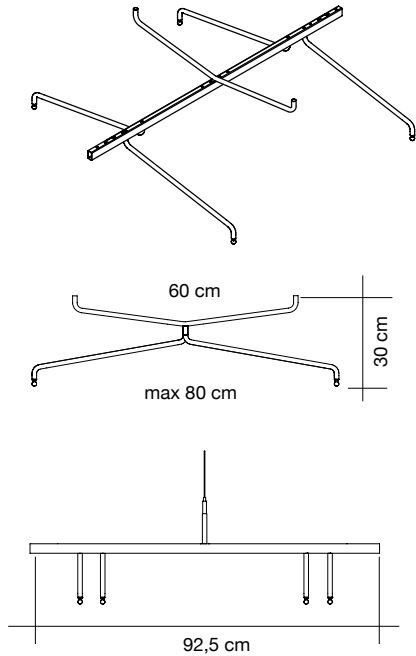

7FC1024-C
Cromato
Chrome-plated
Chromé
Cromado
Verchromt

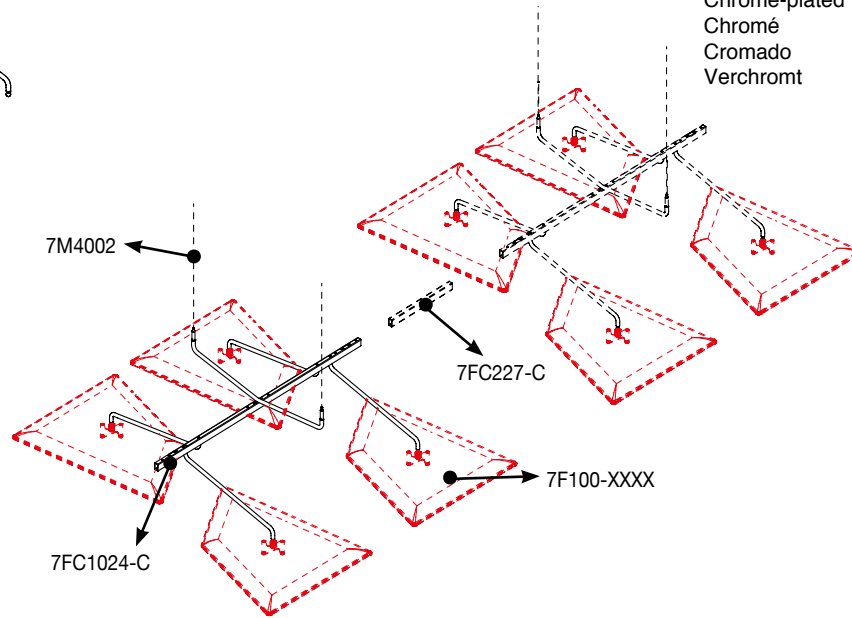

Telaio in acciaio cromato per appendimento a soffitto di 4 pannelli Flap cod. 7F100-XXXX (XXXX = Variante colore).
Telaio **MODULARE**, per utilizzo in composizioni collegate in linea mediante giunto lineare 7FC227-C.

Chrome-plated frame for fixing to the ceiling four Flap panels code 7F100-XXX (XXXX = Color option).
MODULAR frame for use with in line compositions linked through linear joint code 7FC227-C

Châssis en acier chromé pour l'accrochage au plafond de 4 panneaux Flap code 7F100-XXXX (XXXX = option couleur).
Châssis **MODULABLE**. Pour compositions linéaires avec joint linéaire code 7FC227-C

Bastidor de acero cromado para fijación al techo de 4 paneles Flap cod. 7F100-XXXX (XXXX = Variante color).
Bastidor **MODULAR** para utilizacion en composiciones vinculadas en linea con enganche lineal 7FC227-C.

Verchromte Halterung zur Deckenmontage von vier Flap Paneelen Art.Nr. 7F100-XXX (XXXX = Farbvariante).
MODULARE Halterung zur Verwendung in zusammengesetzten Konstruktionen, die mit dem Reihenverbinder Art. Nr. 7FC227-C verbunden werden.

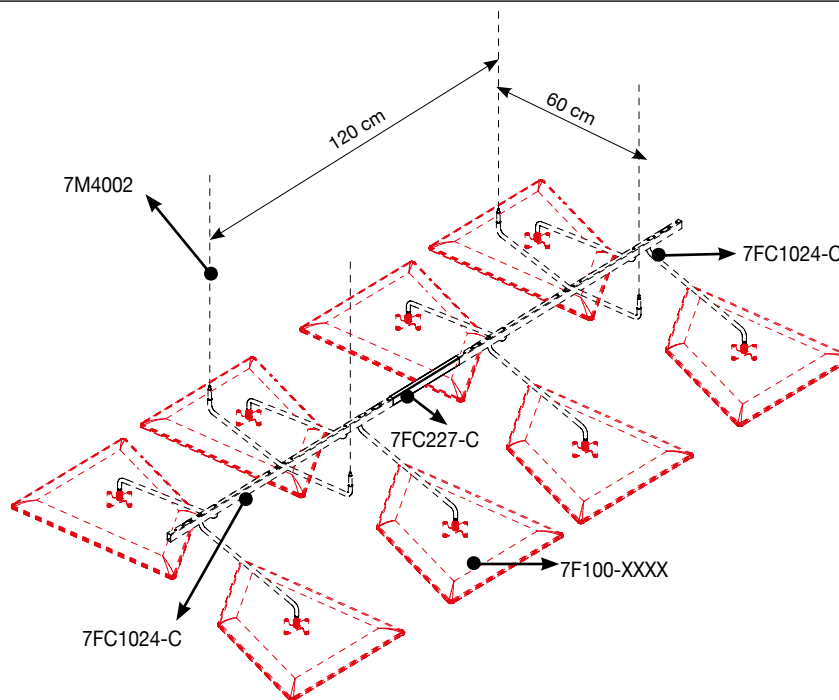
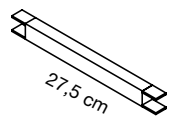

7FC227-C
Cromato
Chrome-plated
Chromé
Cromado
Verchromt

Giunto lineare in acciaio cromato per telai da 4 pannelli Flap cod. 7FC1024-C.

Chrome-plated joint for four Flap panels frame code 7FC1024-C.

Joint linéaire en acier chromé pour châssis 4 panneaux Flap code 7FC1024-C.

Enganche lineal de acero cromado para bastidores de 4 paneles Flap cod 7FC1024-C.

Reihenverbinder für Halterung 7FC1024-C.

FLAP CEILING

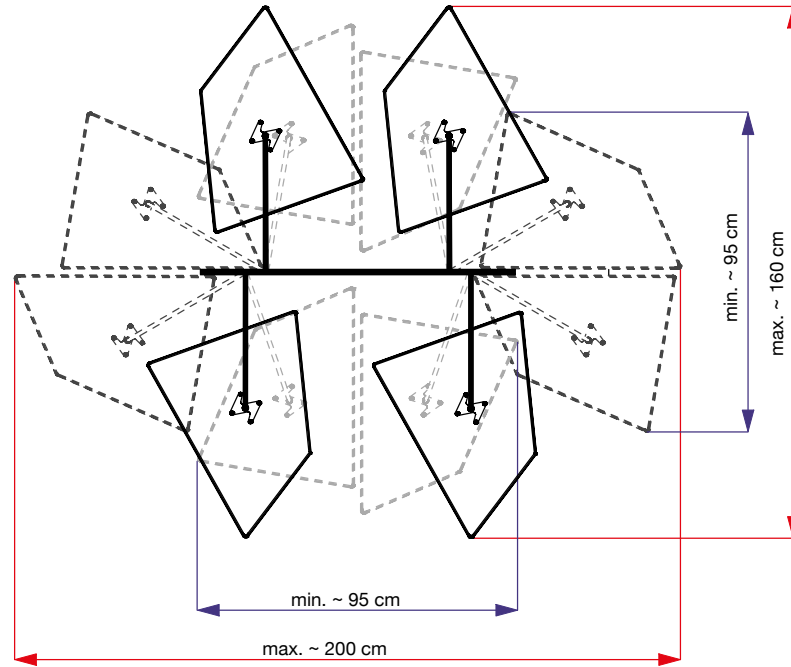

**code
7FC2024-C**

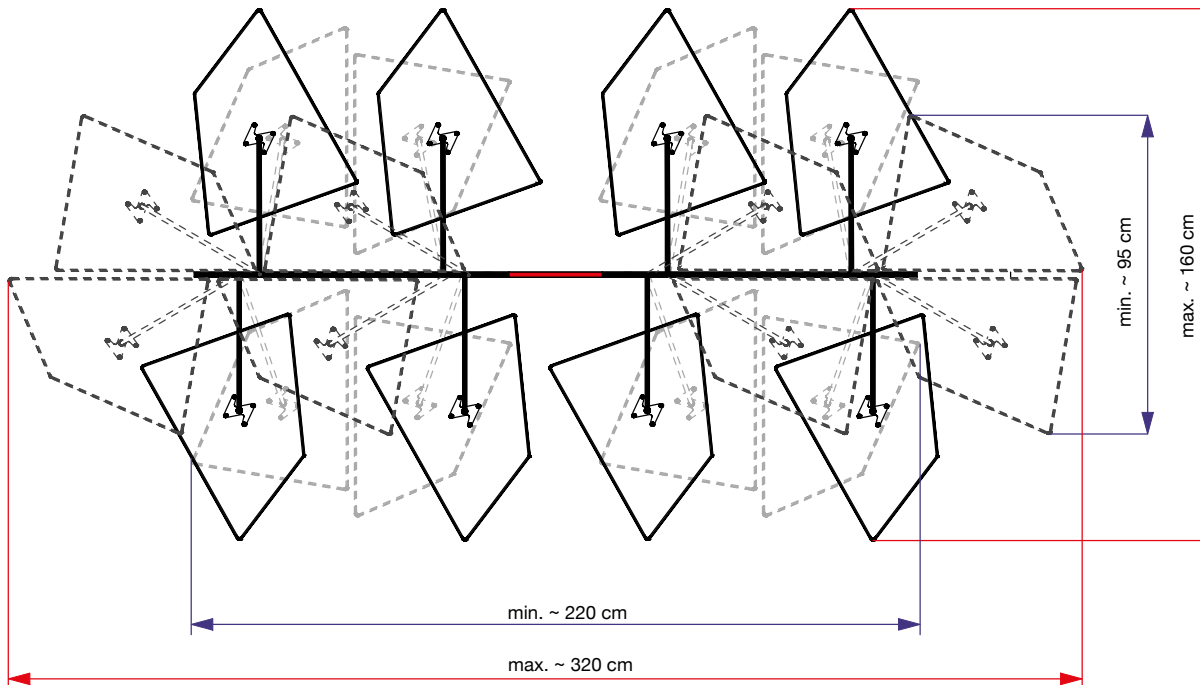

**code
7FC1024-C**

+

**code
7FC227-C**

+

**code
7FC1024-C**

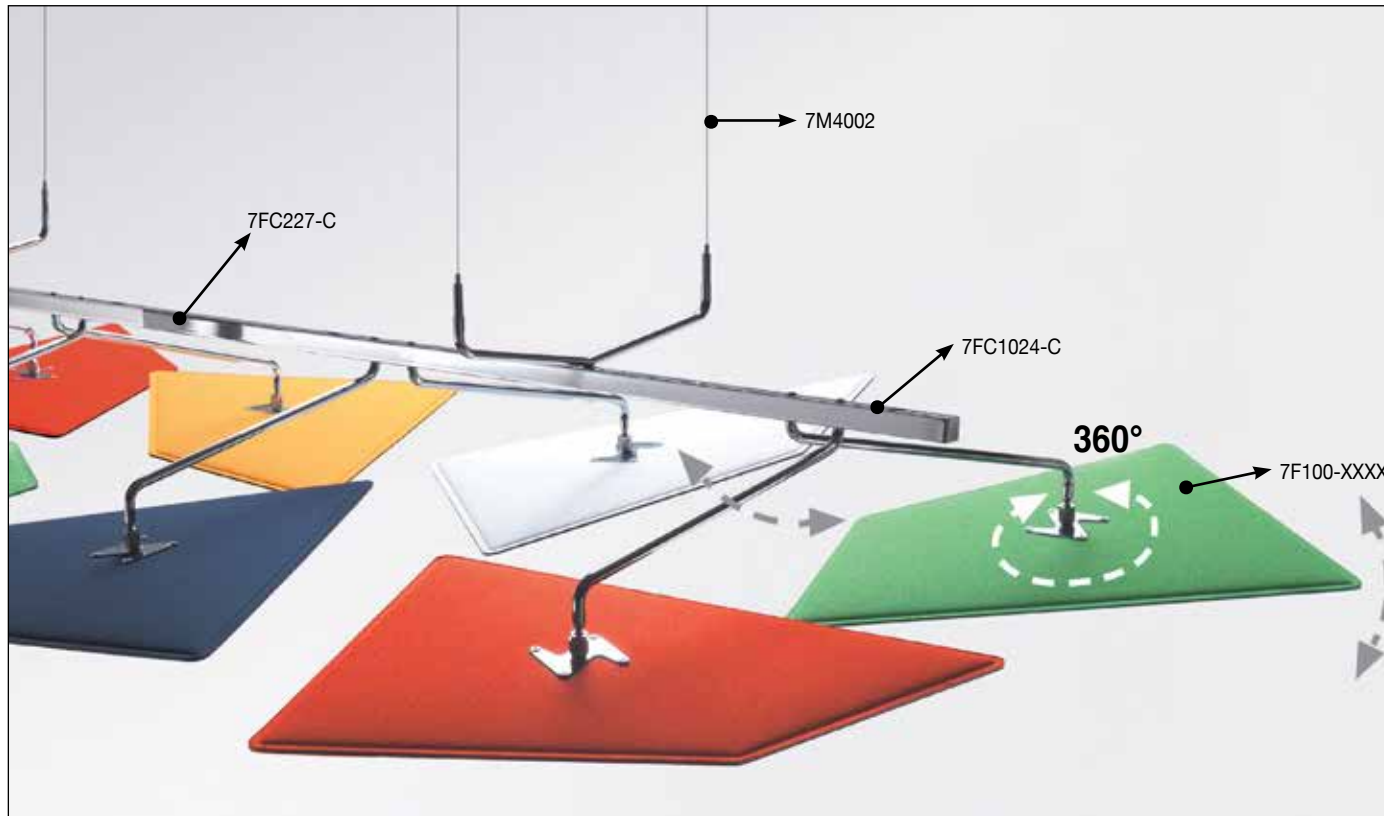

FLAP

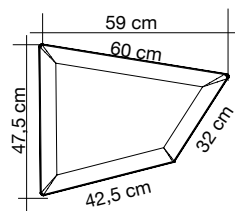
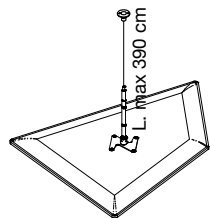

Colore
Colour

Codice/Code
Prezzo/Price



7FC9100-0001

Colore
Colour

Codice/Code
Prezzo/Price



7FC9100-4030



7FC9100-8004



7FC9100-4027

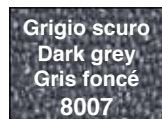

7FC9100-8007



7FC9100-7004



7FC9100-1008

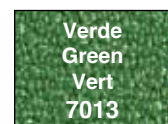

7FC9100-7013



7FC9100-2005

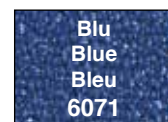

7FC9100-6071



7FC9100-3008

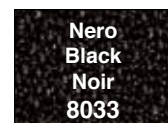

7FC9100-8033

MAXI FLAP

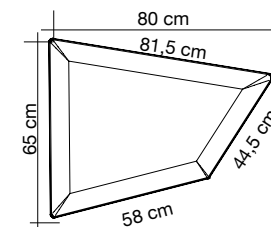
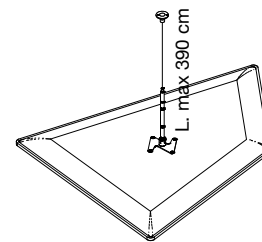

Colore
Colour

Codice/Code
Prezzo/Price



7FC9200-0001

Colore
Colour

Codice/Code
Prezzo/Price



7FC9200-4030



7FC9200-8004



7FC9200-4027

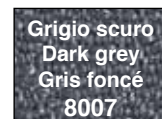

7FC9200-8007

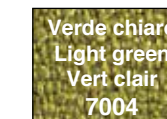

7FC9200-7004



7FC9200-1008



7FC9200-7013



7FC9200-2005



7FC9200-6071



7FC9200-3008

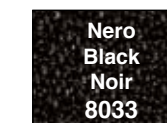

7FC9200-8033

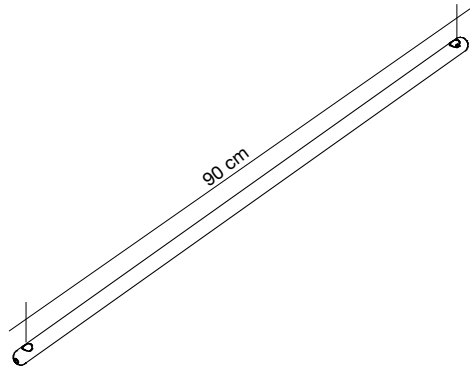

7FT90-C
 Cromato
 Chrome-plated
 Chromé
 Cromado
 Verchromt

Barra di collegamento in acciaio cromato
 Chrome-plated steel connecting rod
 Barre de liaison en acier chromé
 Barra de acoplamiento de acero cromado
 Chromstahl-Verbindungsstange

Descrizione pannello
Panel description

Pannello con imbottitura interna in poliester a **densità variabile** Snowsound® Technology. Rivestimento esterno in tessuto di poliester Trevira CS®. Piastra e snodo in acciaio cromato. Astina cromata con sistema di regolazione dell'altezza del cavo. Completo di kit per fissaggio a soffitto composto da piastra a soffitto a 2 fori e cavo in acciaio. Il pannello è inclinabile in tutte le direzioni e può ruotare di 360°.

Panel with polyester internal padding with Snowsound® Technology **variable density**. Polyester covering in Trevira CS® fabric. Chrome-plated steel plate and joint. Chrome-plated rod with cable height adjustment system. Equipped with Kit for the ceiling fixing composed of: ceiling plate with 2 holes and steel cable. The panel can be tilted in any direction and can rotate 360 degrees.

Panneau avec rembourrage interne en polyester à **densité variable** Snowsound® Technology. Revêtement externe en tissu de polyester Trevira CS®. Platine et articulation en acier chromé. Tige chromée avec système de réglage de la hauteur du câble. Fourni avec kit d'accrochage au plafond composé de plaque pour plafond à 2 trous et câble en acier. Le panneau peut être incliné dans toutes les directions et pivoter sur 360°.

Panel con acolchado interior de poliéster de **densidad variable** Snowsound® Technology. Revestimiento exterior en tejido de poliéster Trevira CS®. Placa y articulación de acero cromado. Varilla cromada con sistema de ajuste de la altura del cable. Completo de kit para el montaje al techo compuesto por placa de techo con 2 huecos y cable de acero. El panel es inclinable en todas direcciones y puede rotar a 360°.

Panel mit Polyester-Füllmaterial von **unterschiedlicher Dichte** Snowsound® Technology. Polyester-Bezug aus Trevira CS®-Material. Platte und Gelenk aus Chromstahl. Verchromter Stab mit System zur Regelung der Kabelhöhe. Ausgestattet mit Set für die Deckenbefestigung bestehend aus Deckenmontageplatten mit 2 Befestigungsbohrungen und Stahlseile. Das Paneel kann in jede Richtung geneigt und um 360 Grad gedreht werden.

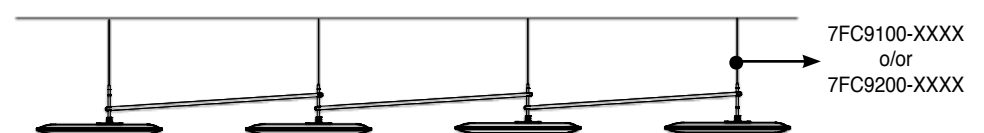
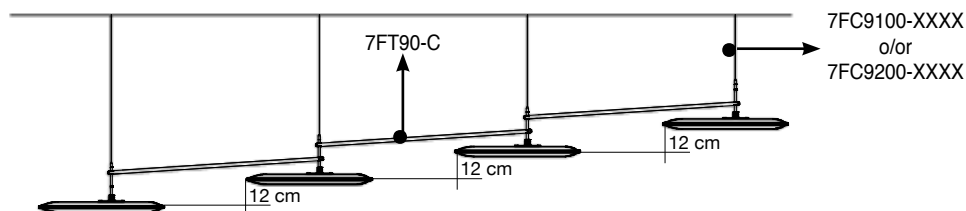

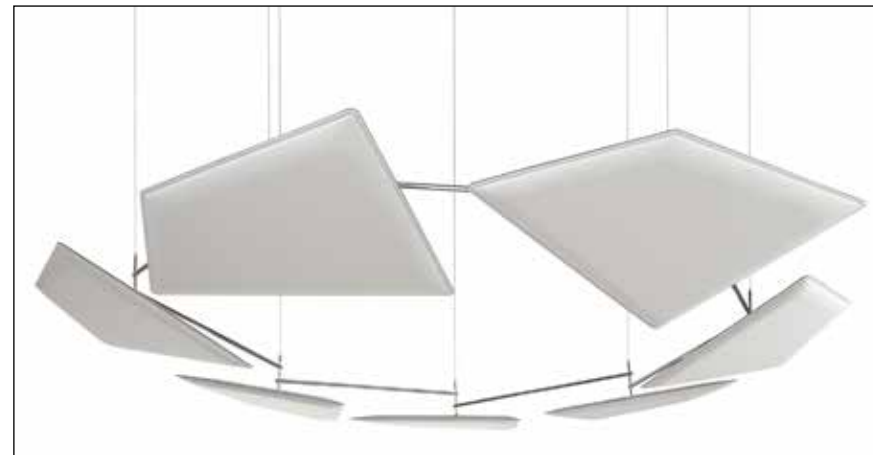
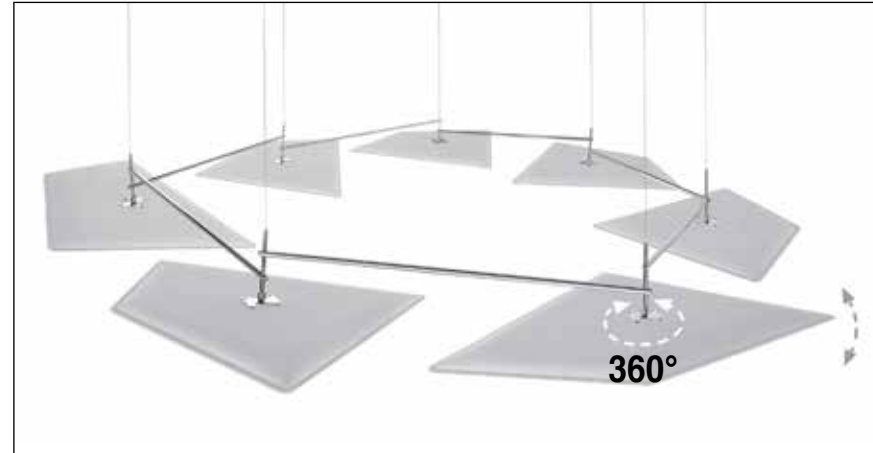
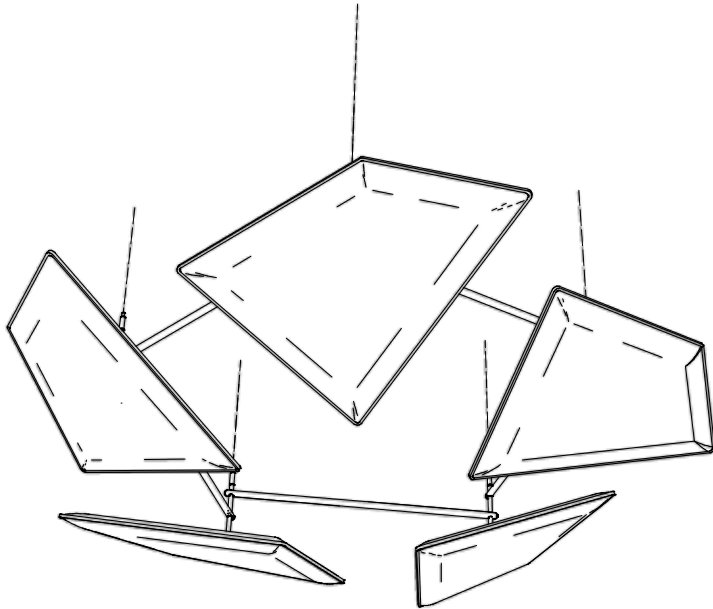

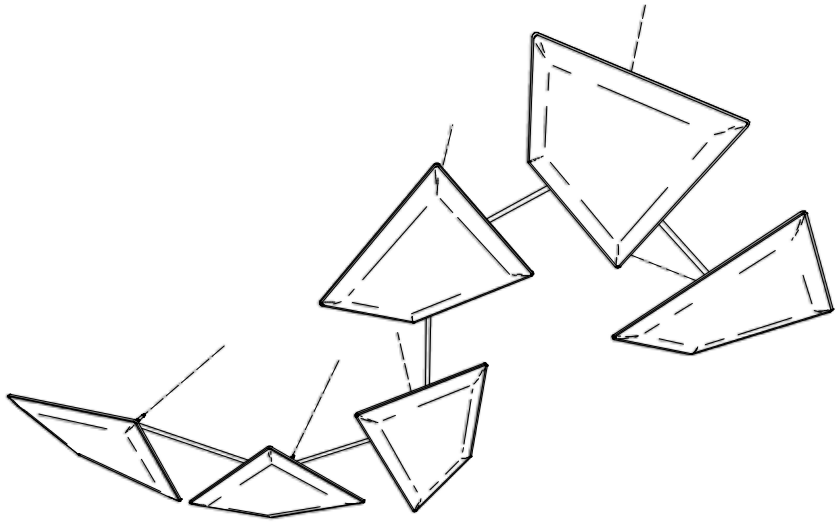

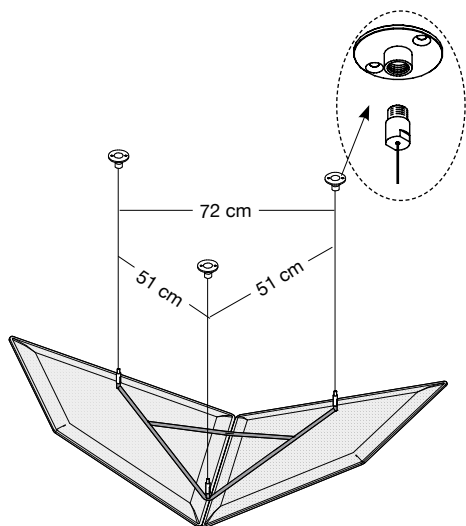

Colore
Colour

Codice/Code
Prezzo/Price

Colore
Colour

Codice/Code
Prezzo/Price

Bianco
White
Blanc
0001

7FV3002-0001

Arancione
Orange
Orange
4030

7FV3002-4030

Grigio argento
Silver grey
Gris argenté
8004

7FV3002-8004

Rosso
Red
Rouge
4027

7FV3002-4027

Grigio scuro
Dark grey
Gris foncé
8007

7FV3002-8007

Verde chiaro
Light green
Vert clair
7004

7FV3002-7004

Beige
Beige
Beige
1008

7FV3002-1008

Verde
Green
Vert
7013

7FV3002-7013

Tortora
Dove-grey
Taupe
2005

7FV3002-2005

Blu
Blue
Bleu
6071

7FV3002-6071

Giallo
Yellow
Jaune
3008

7FV3002-3008

Nero
Black
Noir
8033

7FV3002-8033

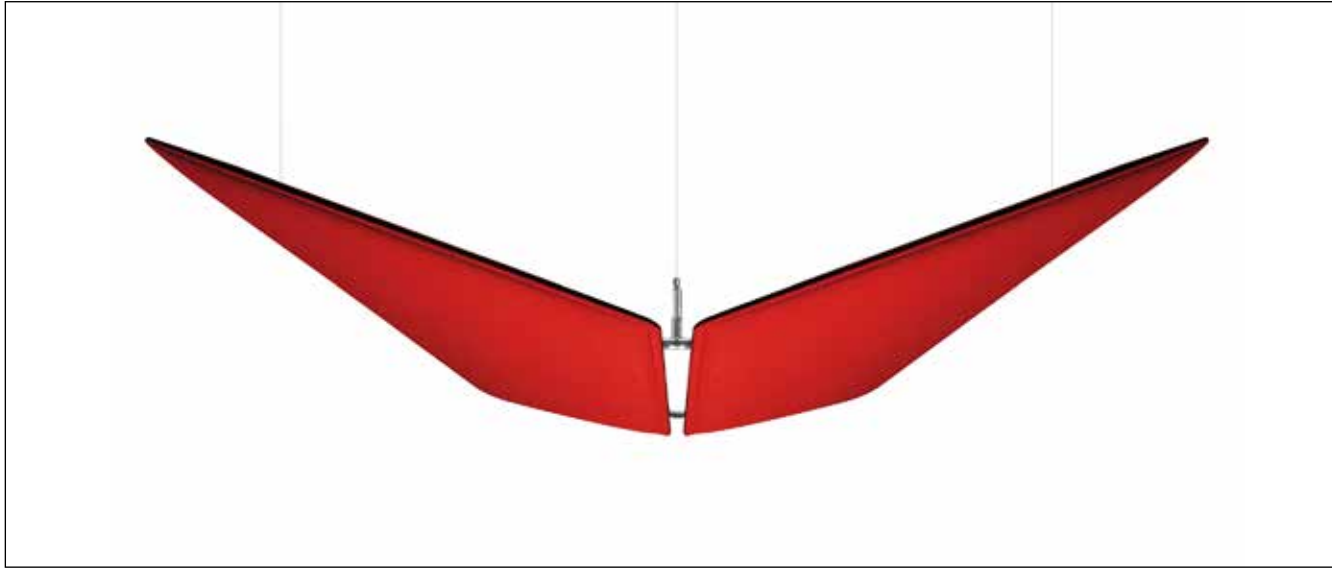

Descrizione
Description

Pannelli con imbottitura interna in poliester a **densità variabile** Snowsound® Technology. Rivestimento esterno in tessuto di poliester Trevira CS®. Completi di struttura in acciaio cromato e kit per fissaggio a soffitto composto da: 3 piastre a soffitto a 2 fori - 3 cavi in acciaio - 3 attacchi per telaio.

Panel with polyester internal padding with Snowsound® Technology **variable density**. Polyester covering in Trevira CS® fabric. Equipped with chrome-plated steel frame and Kit for the ceiling fixing composed of: 3 ceiling plates with 2 holes, 3 steel cables, 3 hangings for frame.





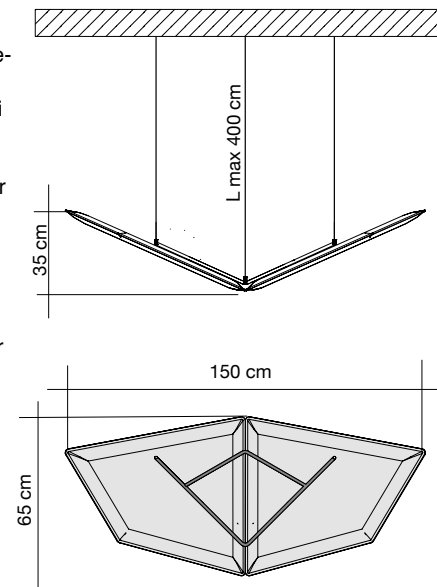

Panneau avec rembourrage interne en polyester à **densité variable** Snowsound® Technology. Revêtement externe en tissu de polyester Trevira CS®. Fourni avec structure en acier chromé et kit d'accrochage au plafond composé de: 3 platines pour plafond à 2 trous - 3 câbles en acier - 3 accrochages pour cadre

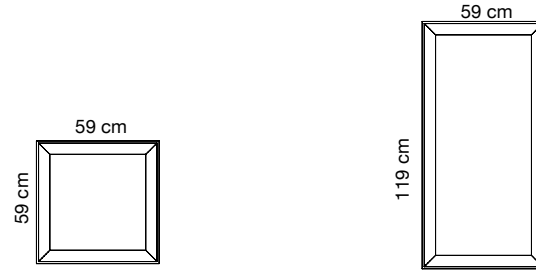
Panel con acolchado interior de poliéster de **densidad variable** Snowsound® Technology. Revestimiento exterior en tejido de poliéster Trevira CS®. Completo de estructura de acero cromado y kit para el montaje al techo compuesto por: 3 placas de techo con 2 huecos - 3 cables de acero - 3 enganches para bastidor.

Panel mit Polyester-Füllmaterial von **unterschiedlicher Dichte** Snowsound® Technology. Polyester-Bezug aus Trevira CS®-Material. Ausgestattet mit Gestell aus verchromtem Stahl und Set für die Deckenbefestigung bestehend aus: 3 Deckenmontageplatten mit 2 Befestigungsbohrungen, 3 Stahlseile, 3 Befestigungen für den Rahmen.





Colore Colour	Codice/Code Prezzo/Price	Codice/Code Prezzo/Price
 Bianco White Blanc 0001	710606-0001	711206-0001
 Grigio argento Silver grey Gris argenté 8004	710606-8004	711206-8004
 Grigio scuro Dark grey Gris foncé 8007	710606-8007	711206-8007
 Beige Beige Beige 1008	710606-1008	711206-1008
 Tortora Dove-grey Taupe 2005	710606-2005	711206-2005
 Giallo Yellow Jaune 3008	710606-3008	711206-3008

Pannello con imbottitura interna in poliester a **densità variabile** Snowsound® Technology. Rivestimento esterno in tessuto di poliester Trevira CS®.

Panel with polyester internal padding with Snowsound® Technology **variable density**. Polyester covering in Trevira CS® fabric.

Panneau avec rembourrage interne en polyester à **densité variable** Snowsound® Technology. Revêtement externe en tissu de polyester Trevira CS®.

Panel con acolchado interior de poliéster de **densidad variable** Snowsound® Technology. Revestimiento exterior en tejido de poliéster Trevira CS®.

Panel mit Polyester-Füllmaterial von **unterschiedlicher Dichte** Snowsound® Technology. Polyester-Bezug aus Trevira CS®-Material.



Colore Colour	Codice/Code Prezzo/Price	Codice/Code Prezzo/Price
Arancione Orange Orange 4030	710606-4030	711206-4030
Rosso Red Rouge 4027	710606-4027	711206-4027
Verde chiaro Light green Vert clair 7004	710606-7004	711206-7004
Verde Green Vert 7013	710606-7013	711206-7013
Blu Blue Bleu 6071	710606-6071	711206-6071
Nero Black Noir 8033	710606-8033	711206-8033

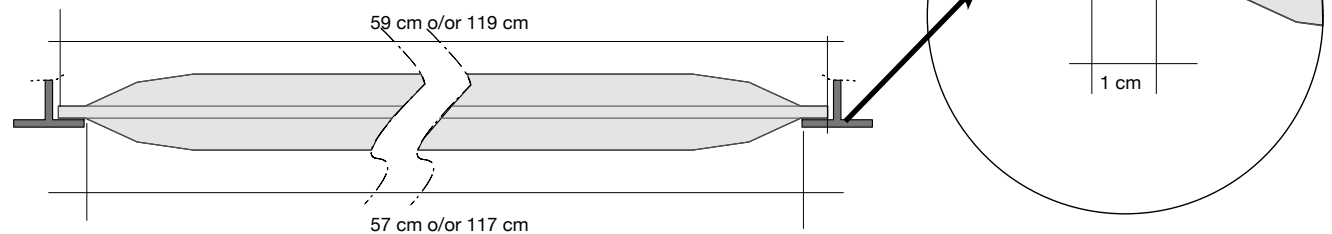

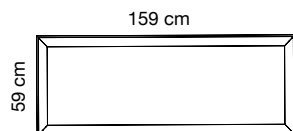

Colore Colour	Codice/Code Prezzo/Price
Bianco White Blanc	0001 7BL1606-0001
Grigio argento Silver grey Gris argenté	8004 7BL1606-8004
Grigio scuro Dark grey Gris foncé	8007 7BL1606-8007
Beige Beige Beige	1008 7BL1606-1008
Tortora Dove-grey Taupe	2005 7BL1606-2005
Giallo Yellow Jaune	3008 7BL1606-3008
Arancione Orange Orange	4030 7BL1606-4030
Rosso Red Rouge	4027 7BL1606-4027
Verde chiaro Light green Vert clair	7004 7BL1606-7004
Verde Green Vert	7013 7BL1606-7013
Blu Blue Bleu	6071 7BL1606-6071
Nero Black Noir	8033 7BL1606-8033

Pannello con imbottitura interna in poliester a **densità variabile** Snowsound® Technology. Rivestimento esterno in tessuto di poliester Trevira CS®.

Panel with polyester internal padding with Snowsound® Technology **variable density**. Polyester covering in Trevira CS® fabric.

Panneau avec rembourrage interne en polyester à **densité variable** Snowsound® Technology. Revêtement externe en tissu de polyester Trevira CS®.

Panel con acolchado interior de poliéster de **densidad variable** Snowsound® Technology. Revestimiento exterior de tejido de poliéster Trevira CS®.

Paneel mit Polyester-Füllmaterial von **unterschiedlicher Dichte** Snowsound® Technology. Polyester-Bezug aus Trevira CS®-Material.



7BL160-BO
Bianco opaco
Mat white
Blanc mat
Blanco mate
Mattweiß

Mensola in acciaio verniciato con polveri epossidiche
Powder coated steel shelf
Tablette en acier peint en époxy
Estante en acero recubierto con polvos epoxidicos
Regalboden aus Epoxypulver beschichtetem Stahl

Portata massima 30 Kg per piano
Maximum load 30 Kg for 1 shelf

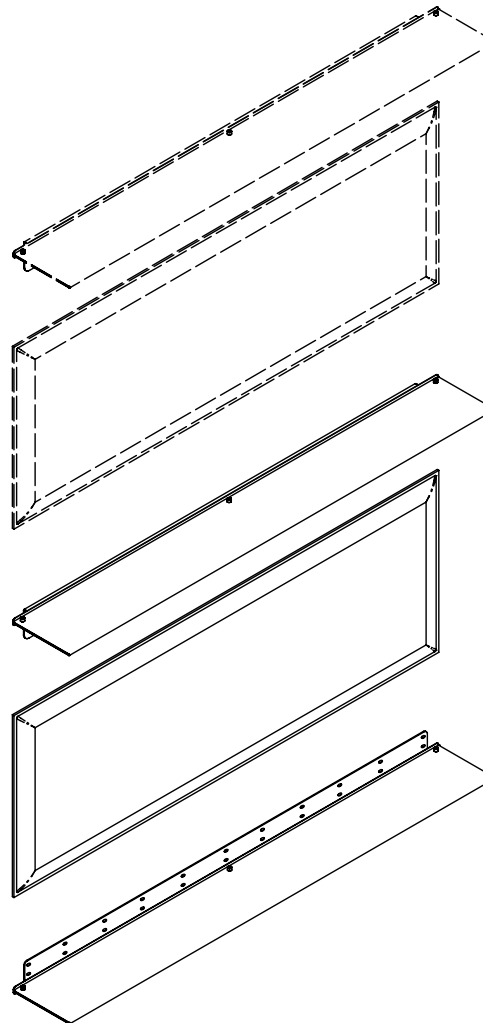
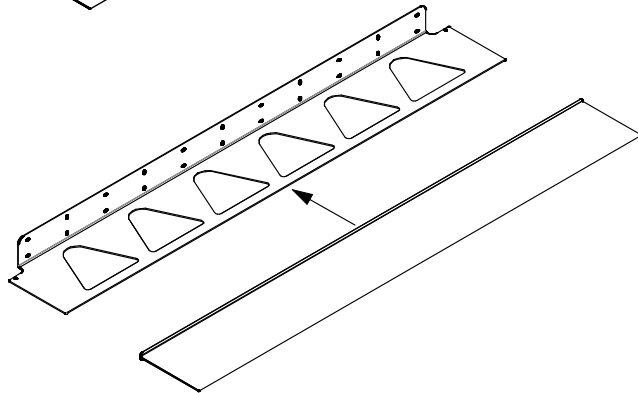
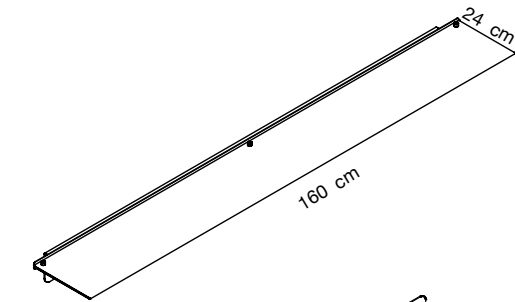

119 cm



Senza titolo / Untitled 1955-2017

7SG16/55-0001 Bianco
White
Blanc
Blanco
Weiß

Pannello con imbottitura interna in poliester a **densità variabile** Snowsound® Technology. Rivestimento esterno in tessuto di poliester Trevira CS®. Applicabile a parete. (**Attacchi non inclusi - vedi pag. 117**).

Snowsound® Technology panel with internal padding in **variable density** polyester. Outer cover in Trevira CS® polyester fabric. Wall mounting. (**Fixings not included - see page 117**).

Panneau avec rembourrage interne en polyester à **densité variable** Snowsound® Technology. Revêtement externe en tissu de polyester Trevira CS®. Application au mur. (**Fixations pas inclus - voir page 117**).

Panel con acolchado interior de poliéster de **densidad variable** Snowsound® Technology. Revestimiento exterior de tejido de poliéster Trevira CS®. Aplicación a pared. (**Fijaciones no incluidas - pag. 117**)

Paneel mit Polyester-Füllmaterial von **unterschiedlicher Dichte** Snowsound® Technology. Polyester-Bezug aus Trevira CS®-Material. Wandanwendung. (**Befestigungen nicht inkludiert - Seite 117**).

119 cm



Senza titolo / Untitled 1955-2017

7SG16/55-4030 Arancione
Orange
Orange
Anaranjado
Orange

Pannello con imbottitura interna in poliester a **densità variabile** Snowsound® Technology. Rivestimento esterno in tessuto di poliester Trevira CS®. Applicabile a parete. (**Attacchi non inclusi - vedi pag. 117**).

Snowsound® Technology panel with internal padding in **variable density** polyester. Outer cover in Trevira CS® polyester fabric. Wall mounting. (**Fixings not included - see page 117**).

Panneau avec rembourrage interne en polyester à **densité variable** Snowsound® Technology. Revêtement externe en tissu de polyester Trevira CS®. Application au mur. (**Fixations pas inclus - voir page 117**).

Panel con acolchado interior de poliéster de **densidad variable** Snowsound® Technology. Revestimiento exterior de tejido de poliéster Trevira CS®. Aplicación a pared. (**Fijaciones no incluidas - pag. 117**)

Paneel mit Polyester-Füllmaterial von **unterschiedlicher Dichte** Snowsound® Technology. Polyester-Bezug aus Trevira CS®-Material. Wandanwendung. (**Befestigungen nicht inkludiert - Seite 117**).

119 cm



Senza titolo / Untitled 1955-2017

7SG16/55-4027 Rosso
Red
Rouge
Rojo
Rot

Pannello con imbottitura interna in poliester a **densità variabile** Snowsound® Technology. Rivestimento esterno in tessuto di poliester Trevira CS®. Applicabile a parete. (**Attacchi non inclusi - vedi pag. 117**).

Snowsound® Technology panel with internal padding in **variable density** polyester. Outer cover in Trevira CS® polyester fabric. Wall mounting. (**Fixings not included - see page 117**).

Panneau avec rembourrage interne en polyester à **densité variable** Snowsound® Technology. Revêtement externe en tissu de polyester Trevira CS®. Application au mur. (**Fixations pas inclus - voir page 117**).

Panel con acolchado interior de poliéster de **densidad variable** Snowsound® Technology. Revestimiento exterior de tejido de poliéster Trevira CS®. Aplicación a pared. (**Fijaciones no incluidas - pag. 117**)

Paneel mit Polyester-Füllmaterial von **unterschiedlicher Dichte** Snowsound® Technology. Polyester-Bezug aus Trevira CS®-Material. Wandanwendung. (**Befestigungen nicht inkludiert - Seite 117**).

119 cm



Senza titolo / Untitled 1955-2017

7SG16/55-8033 Nero
Black
Noir
Negro
Schwarz

Pannello con imbottitura interna in poliester a **densità variabile** Snowsound® Technology. Rivestimento esterno in tessuto di poliester Trevira CS®. Applicabile a parete. (**Attacchi non inclusi - vedi pag. 117**).

Snowsound® Technology panel with internal padding in **variable density** polyester. Outer cover in Trevira CS® polyester fabric. Wall mounting. (**Fixings not included - see page 117**).

Panneau avec rembourrage interne en polyester à **densité variable** Snowsound® Technology. Revêtement externe en tissu de polyester Trevira CS®. Application au mur. (**Fixations pas inclus - voir page 117**).

Panel con acolchado interior de poliéster de **densidad variable** Snowsound® Technology. Revestimiento exterior de tejido de poliéster Trevira CS®. Aplicación a pared. (**Fijaciones no incluidas - pag. 117**)

Paneel mit Polyester-Füllmaterial von **unterschiedlicher Dichte** Snowsound® Technology. Polyester-Bezug aus Trevira CS®-Material. Wandanwendung. (**Befestigungen nicht inkludiert - Seite 117**).

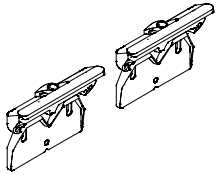

7S370-BO
Bianco opaco
Mat white
Blanc mat
Blanco mate
Mattweiß

1 coppia / 1 pair
1 paire / 1 pare
1 Paar

Coppia attacchi a parete in zama verniciata o nichel satinata.
Per il fissaggio a parete, è necessaria 1 coppia di attacchi per ogni pannello Snowsound Art. Per cod. 7SG16/55-0001 / 7SG16/55-4030 / 7SG16/55-4027 / 7SG16/55-8033.

Pair of wall fixings in zamac, painted or nickel satinated.
For wall mounting, a set of two fixings is required for each Snowsound Art panel. For codes 7SG16/55-0001 / 7SG16/55-4030 / 7SG16/55-4027 / 7SG16/55-8033.



7S370-C
Nichel satinato
Nickel satinéd
Nickel satinée
Niquel satinado
Nickel satiniert

1 coppia / 1 pair
1 paire / 1 pare
1 Paar

Paire de fixations murales en zamak peinte ou nickel satinée. Pour la fixation au mur il faut 1 paire de joints pour chaque panneau Snowsound Art. Pour réf. 7SG16/55-0001 / 7SG16/55-4030 / 7SG16/55-4027 / 7SG16/55-8033.

Set de fijaciones a pared en zamac, pintado o niquel satinado. Para montaje a pared, se necesita un set de 2 pzs. para cada panel Snowsound Art. Para cod. 7SG16/55-0001 / 7SG16/55-4030 / 7SG16/55-4027 / 7SG16/55-8033.

1 Paar Wandbefestigungen aus Zamak, lackiert oder Nickel satiniert. Für die Wandmontage wird ein Paar Befestigungen für jedes Snowsound Art Paneel benötigt. Fur Art. 7SG16/55-0001 / 7SG16/55-4030 / 7SG16/55-4027 / 7SG16/55-8033.



159 cm



119 cm

Senza titolo / Untitled 1937-2017

7SG16/37-0001 Bianco
White
Blanc
Blanco
Weiß

Pannello con imbottitura interna in poliestere a **densità variabile** Snowsound® Technology. Rivestimento esterno in tessuto di poliestere Trevira CS®. Applicabile a parete o a soffitto. **(Attacchi non inclusi - vedi pag. 119).**

Snowsound® Technology panel with internal padding in **variable density** polyester. Outer cover in Trevira CS® polyester fabric. Wall or ceiling mounting. **(Fixings not included - see page 119).**

Panneau avec rembourrage interne en polyester à **densité variable** Snowsound® Technology. Revêtement externe en tissu de polyester Trevira CS®. Application mur ou plafond. **(Fixations pas inclus - voir page 119).**

Panel con acolchado interior de poliéster de **densidad variable** Snowsound® Technology. Revestimiento exterior de tejido de poliéster Trevira CS®. Aplicación pared o techo. **(Fijaciones no incluidas - page 119)**

Paneel mit Polyester-Füllmaterial von **unterschiedlicher Dichte** Snowsound® Technology. Polyester-Bezug aus Trevira CS®-Material. Decke-oder Wandanwendung. **(Befestigungen nicht inkludiert - Seite 119).**

159 cm

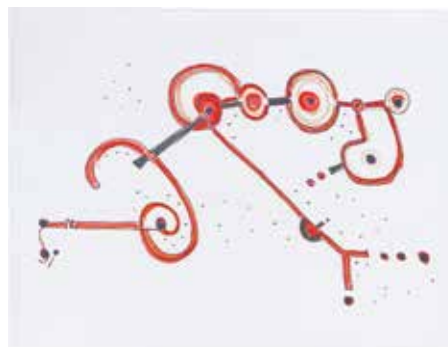

119 cm

Senza titolo / Untitled 1991

7SG16/91-0001 Bianco
White
Blanc
Blanco
Weiß

Pannello con imbottitura interna in poliestere a **densità variabile** Snowsound® Technology. Rivestimento esterno in tessuto di poliestere Trevira CS®. Applicabile a parete o a soffitto. **(Attacchi non inclusi - vedi pag. 119).**

Snowsound® Technology panel with internal padding in **variable density** polyester. Outer cover in Trevira CS® polyester fabric. Wall or ceiling mounting. **(Fixings not included - see page 119).**

Panneau avec rembourrage interne en polyester à **densité variable** Snowsound® Technology. Revêtement externe en tissu de polyester Trevira CS®. Application mur ou plafond. **(Fixations pas inclus - voir page 119).**

Panel con acolchado interior de poliéster de **densidad variable** Snowsound® Technology. Revestimiento exterior de tejido de poliéster Trevira CS®. Aplicación pared o techo. **(Fijaciones no incluidas - page 119)**

Paneel mit Polyester-Füllmaterial von **unterschiedlicher Dichte** Snowsound® Technology. Polyester-Bezug aus Trevira CS®-Material. Decke-oder Wandanwendung. **(Befestigungen nicht inkludiert - Seite 119).**

119 cm



119 cm

Senza titolo / Untitled 1998

7SG12/98-0001 Bianco
White
Blanc
Blanco
Weiß

Pannello con imbottitura interna in poliestere a **densità variabile** Snowsound® Technology. Rivestimento esterno in tessuto di poliestere Trevira CS®. Applicabile a parete o a soffitto. **(Attacchi non inclusi - vedi pag. 119).**

Snowsound® Technology panel with internal padding in **variable density** polyester. Outer cover in Trevira CS® polyester fabric. Wall or ceiling mounting. **(Fixings not included - see page 119).**

Panneau avec rembourrage interne en polyester à **densité variable** Snowsound® Technology. Revêtement externe en tissu de polyester Trevira CS®. Application mur ou plafond. **(Fixations pas inclus - voir page 119).**

Panel con acolchado interior de poliéster de **densidad variable** Snowsound® Technology. Revestimiento exterior de tejido de poliéster Trevira CS®. Aplicación pared o techo. **(Fijaciones no incluidas - page 119)**

Paneel mit Polyester-Füllmaterial von **unterschiedlicher Dichte** Snowsound® Technology. Polyester-Bezug aus Trevira CS®-Material. Decke-oder Wandanwendung. **(Befestigungen nicht inkludiert - Seite 119).**

119 cm



119 cm

Senza titolo / Untitled 1998

7SG12/98-8033 Nero
Black
Noir
Negro
Schwarz

Pannello con imbottitura interna in poliestere a **densità variabile** Snowsound® Technology. Rivestimento esterno in tessuto di poliestere Trevira CS®. Applicabile a parete o a soffitto. **(Attacchi non inclusi - vedi pag. 119).**

Snowsound® Technology panel with internal padding in **variable density** polyester. Outer cover in Trevira CS® polyester fabric. Wall or ceiling mounting. **(Fixings not included - see page 119).**

Panneau avec rembourrage interne en polyester à **densité variable** Snowsound® Technology. Revêtement externe en tissu de polyester Trevira CS®. Application mur ou plafond. **(Fixations pas inclus - voir page 119).**

Panel con acolchado interior de poliéster de **densidad variable** Snowsound® Technology. Revestimiento exterior de tejido de poliéster Trevira CS®. Aplicación pared o techo. **(Fijaciones no incluidas - page 119)**

Paneel mit Polyester-Füllmaterial von **unterschiedlicher Dichte** Snowsound® Technology. Polyester-Bezug aus Trevira CS®-Material. Decke-oder Wandanwendung. **(Befestigungen nicht inkludiert - Seite 119).**

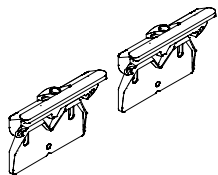

7S370-BO
Bianco opaco
Mat white
Blanc mat
Blanco mate
Mattweiß

1 coppia / 1 pair
1 paire / 1 pare
1 Paar



7S370-C
Nichel satinato
Nickel satinéd
Nickel satinée
Niquel satinado
Nickel satiniert

1 coppia / 1 pair
1 paire / 1 pare
1 Paar

Coppia attacchi a parete in zama verniciata o nichel satinata. Per il fissaggio a parete, è necessaria 1 coppia di attacchi per ogni pannello Snowsound Art. Per cod. 7SG16/37-0001 / 7SG16/91-0001 / 7SG12/98-0001 / 7SG12/98-8033.

Pair of wall fixings in zamac, painted or nickel satinéd. For wall mounting, a set of two fixings is required for each Snowsound Art panel. For codes 7SG16/37-0001 / 7SG16/91-0001 / 7SG12/98-0001 / 7SG12/98-8033.

Paire de fixations murales en zamak peinte ou nickel satinée. Pour fixation au mur utiliser 1 paire de joints pour chaque panneau Snowsound Art. Pour réf. 7SG16/37-0001 / 7SG16/91-0001 / 7SG12/98-0001 / 7SG12/98-8033.

Set de fijaciones a pared en zamac, pintado o niquel satinado. Para montaje a pared, se necesita un set de 2 pzs. para cada panel Snowsound Art. Para cod. 7SG16/37-0001 / 7SG16/91-0001 / 7SG12/98-0001 / 7SG12/98-8033.

1 Paar Wandbefestigungen aus Zamak, lackiert oder Nickel satiniert. Für die Wandmontage wird ein Paar Befestigungen für jedes Snowsound Art Paneel benötigt. Für Art. 7SG16/37-0001 / 7SG16/91-0001 / 7SG12/98-0001 / 7SG12/98-8033.

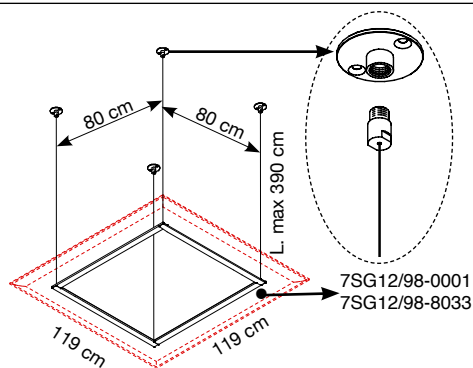

7OSF120

Struttura in acciaio e kit per fissaggio a soffitto composto da: 4 piastre a soffitto a 2 fori - 4 cavi in acciaio - 4 attacchi per telaio. Per il fissaggio a soffitto pannelli Snowsound Art 119x119 cm. Per cod. 7SG12/98-0001 / 7SG12/98-8033

Steel frame and kit for ceiling fixing composed of: 4 ceiling plates with 2 holes, 4 steel cables, 4 frame connection. For ceiling mounting of Snowsound Art panels 119x119 cm. For codes 7SG12/98-0001 / 7SG12/98-8033.

Structure en acier et kit d'accrochage au plafond composé de: 4 platines pour plafond à 2 trous - 4 câbles en acier - 4 accrochages pour cadre. Pour la fixation au plafond des panneaux Snowsound Art 119x119 cm.

Estructura de acero y kit para el montaje al techo compuesto por: 4 placas de techo con 2 huecos - 4 cables de acero - 4 enganches para bastidor. Para montaje a techo del panel de 119x119 Snowsound Art.

Gestell aus Stahl und Set für die Deckenbefestigung bestehend aus: 4 Deckenmontageplatten mit 2 Befestigungsbohrungen, 4 Stahlseile, 4 Befestigungen für den Rahmen. Für die Deckenmontage der Snowsound Art Paneele 119 x 119 cm.

Per cod. / For codes / Pour réf. /
Para code / Fur Art.
7SG12/98-0001 / 7SG12/98-8033.

Peso 8,5 Kg (struttura + pannello)
Weight 8,5 Kg (frame + panel)

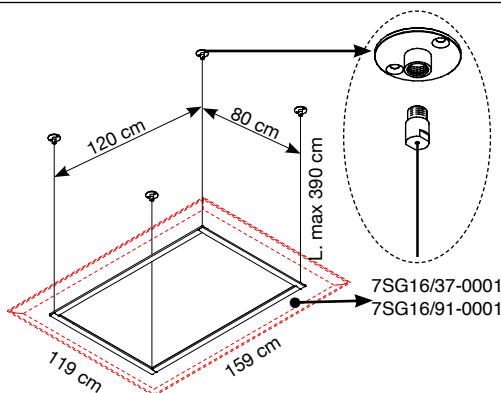

7OSF160

Struttura in acciaio e kit per fissaggio a soffitto composto da: 4 piastre a soffitto a 2 fori - 4 cavi in acciaio - 4 attacchi per telaio. Per il fissaggio a soffitto pannelli Snowsound Art 119x159 cm. Per cod. 7SG16/37-0001 / 7SG16/91-0001

Steel frame and kit for ceiling fixing composed of: 4 ceiling plates with 2 holes, 4 steel cables, 4 frame connection. For ceiling mounting of Snowsound Art panels 119x159 cm. For codes 7SG16/37-0001 / 7SG16/91-0001

Structure en acier et kit d'accrochage au plafond composé de: 4 platines pour plafond à 2 trous - 4 câbles en acier - 4 accrochages pour cadre. Pour la fixation au plafond des panneaux Snowsound Art 119x159 cm.

Estructura de acero y kit para el montaje al techo compuesto por: 4 placas de techo con 2 huecos - 4 cables de acero - 4 enganches para bastidor. Para montaje a techo del panel de 119x159 Snowsound Art.

Gestell aus Stahl und Set für die Deckenbefestigung bestehend aus: 4 Deckenmontageplatten mit 2 Befestigungsbohrungen, 4 Stahlseile, 4 Befestigungen für den Rahmen. Für die Deckenmontage der Paneele 119 x 159 cm.

Per cod. / For codes / Pour réf. /
Para code / Fur Art.
7SG16/37-0001 / 7SG16/91-0001

Peso 10,5 Kg (struttura + pannello)
Weight 10,5 Kg (frame + panel)

7SM6-C

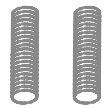

Per M6 (non inclusa)
For M6 (not included)

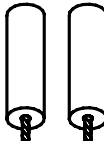

1 coppia / 1 pair
1 paire / 1 pare
1 Paar

OPZIONALE / OPTIONAL

Coppia attacchi per viti M6. Utilizzabile per tutte le applicazioni a soffitto. Può sostituire la piastra a due fori fornita con i pannelli (dove prevista)

Pair of connections for M6 screws. Can be used for all ceiling applications. Can replace the two holes plate supplied with the panels (where applicable)

Paire de raccords pour vis M6. Peut être utilisé pour toutes les applications au plafond. Peut remplacer la platine à deux trous fournie avec les panneaux (le cas échéant)

Par de conexiones para tornillos M6. Se puede utilizar para todas las aplicaciones de techo. Puede sustituir la placa con dos huecos suministrada con los paneles (si procede)

Paar von Befestigungen für M6 Schrauben. Für alle Deckenarten geeignet. Kann an Stelle der mitgelieferten Montageplatte mit zwei Lochungen verwendet werden.

7SL/RD7-BO

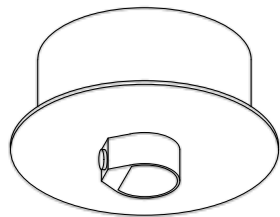

ø 7 cm

OPZIONALE / OPTIONAL

Rosone per pannelli:

OVERSIZE LUX cod. 7OL1212/1F-XXXX / 7OL1216/2F-XXXX /
7OL1212/L6-XXXX / 7OL1216/L9
GIOTTO LUX cod. 7GL120-XXXX

Ceiling rose for panels:

OVERSIZE LUX codes 7OL1212/1F-XXXX / 7OL1216/2F-XXXX /
7OL1212/L6-XXXX / 7OL1216/L9
GIOTTO LUX code 7GL120-XXXX

Rosace pour panneaux:

OVERSIZE LUX cod. 7OL1212/1F-XXXX / 7OL1216/2F-XXXX /
7OL1212/L6-XXXX / 7OL1216/L9
GIOTTO LUX cod. 7GL120-XXXX

Rosetón para paneles:

OVERSIZE LUX cod. 7OL1212/1F-XXXX / 7OL1216/2F-XXXX /
7OL1212/L6-XXXX / 7OL1216/L9
GIOTTO LUX cod. 7GL120-XXXX

Rosette für paneele:

OVERSIZE LUX Art. 7OL1212/1F-XXXX / 7OL1216/2F-XXXX /
7OL1212/L6-XXXX / 7OL1216/L9
GIOTTO LUX Art. 7GL120-XXXX

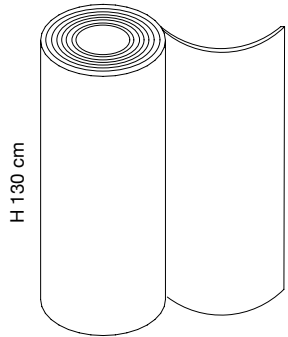

H 130 cm

L. 600 cm

1 Rotolo = 7,8 m²



Colore
Colour



Bianco
White
Blanc
Weiss
Blanco



Grigio argento
Silver grey
Gris argenté
Gris plata
Silbergrau



Beige
Beige
Beige
Beige
Beige



Verde
Green
Vert
Verde
Grüner



Rosso
Red
Rouge
Rojo
Rot

Codice/Code
Prezzo/Price

7SW6-0001

7SW6-8004

7SW6-1008

7SW6-7013

7SW6-4027

Rotolo di feltro in Poliestere rivestito in tessuto di poliestere Trevira CS®.

Roll of polyester felt coated with Trevira CS® polyester fabric.

Rouleau de feutre en Polyester recouvert en tissu de polyester Trevira CS®.

Rollo de fieltro de poliéster tapizado con tejido de poliéster Trevira CS®.

Rolle von Polyester-Filz, bezogen mit Trevira CS® Polyesterstoff.



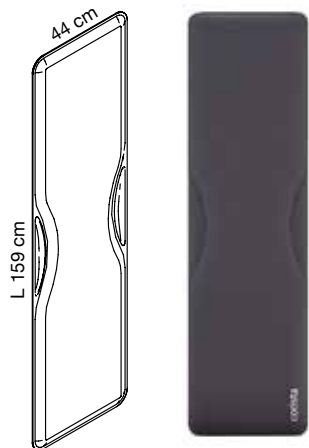

7C164-8033

Nero
Black
Noir

Pannello con imbottitura interna in poliester a **densità variabile** Snowsound® Technology e rivestimento esterno in tessuto di poliester Trevira CS®. Peso del singolo pannello 2,5 Kg.

Panel with polyester internal padding with Snowsound® Technology **variable density** and polyester covering in Trevira CS® fabric. Weight of the single panel: 2,5 kg

Panneau avec rembourrage interne en polyester à **densité variable** Snowsound® Technology et revêtement externe en tissu de polyester Trevira CS®. Poids d'un panneau: 2,5 kg

Panel con acolchado interior de poliéster de **densidad variable** Snowsound® Technology y revestimiento exterior de tejido de poliéster Trevira CS®. Peso para singulo panel 2,5 Kg

Paneel mit Polyester-Füllmaterial von **unterschiedlicher Dichte** Snowsound® Technology und Polyester-Bezug aus Trevira CS®-Material. Gewicht eines Paneels: 2,5 kg.

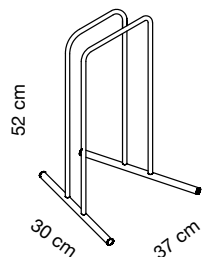

7C510/1-N

Nero
Black
Noir
Negro
Schwarz

Cavalletto in acciaio verniciato con polveri epossidiche per 1 pannello Corista o Mitesco.

Epoxy powder-coated steel stand for one Corista or Mitesco panel.

Chevalet en acier peint époxy pour 1 panneau Corista ou Mitesco.

Soporte de acero recubierto epoxi para 1 panel Corista o Mitesco.

Standfuß aus pulverbeschichtetem Stahl für ein Corista oder Mitesco Paneel

7C164-BORSA

Borsa per pannelli Corista e Mitesco. Può contenere fino a 4 pannelli lunghezza 159 cm.

Carry bag for Corista and Mitesco panels. Contains up to four panels 159 cm long.

Sac pour panneaux Corista et Mitesco. Il peut contenir un maximum de 4 panneaux L.159 cm.

Bolsa para paneles Corista o Mitesco. Puede contener hasta 4 paneles L.159 cm.

Tragtasche für Corista und Mitesco Paneele, für bis zu 4 Paneele mit 159 cm Länge



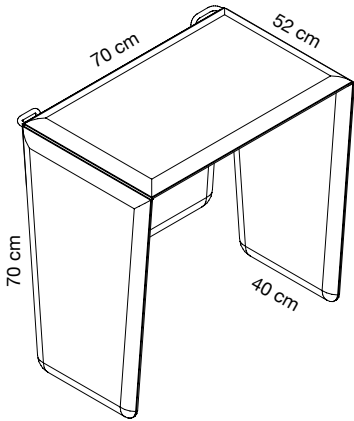

7CK700-8004

Grigio argento
Silver grey
Gris argenté

7CK700-4027

Rosso
Red
Rouge

Phone boot con struttura in tondino di acciaio verniciato e copertura composta da imbottitura interna in poliester e rivestimento esterno in tessuto di poliester Trevira CS®, completamente sfoderabile.

Phone booth with powder-coated steel rod structure, cover composed by polyester internal padding and polyester Trevira CS® fabric external coating, totally removable.

Cabine avec structure en tiges d'acier peint epoxy et couverture avec rembourrage interne en polyester et revêtement externe en tissu de polyester Trevira CS entièrement amovible.

Phone Boot con estructura de hilo de acero recubierto y cobertura compuesta para acolchado interior en poliester y revestimiento exterior de tejido de poliester Trevira CS, totalmente amovible.

Telefonzelle mit Gestell aus beschichtetem Stahlrohr zur Wandmontage, Abdeckung bestehend aus einer Polyester-Polsterung und einem komplett abziehbaren Bezug aus Polyesterstoff Trevira CS®

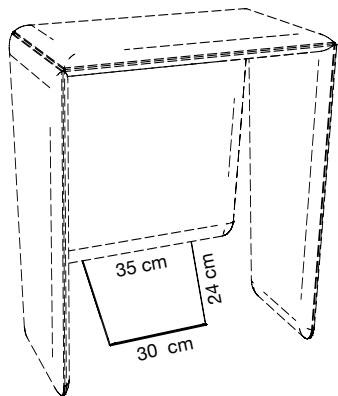

7CK500-GA

Grigio argento
Silver grey
Gris argenté
Gris plata
Silbergrau



Piano in acciaio verniciato per con polveri epossidiche per phone boot Cocker.

Powder-coated steel shelf for phone boot Cocker.

Tablette en acier peint epoxy pour cabine Cocker

Estante en acero recubierto para phone boot Cocker

Beschichteter Regalboden für Telefonzelle Cocker



SNOWSOUND FIBER

COLORI TESSUTI - TEXTILES' COLORS - COULEURS TISSUS -
COLORES DE TELAS - STOFFFARBEN

0001



FIBER 1 COLOR

8004



FIBER 1 COLOR

1008

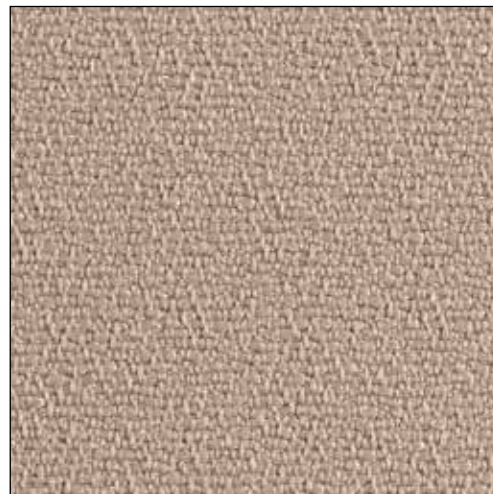

FIBER 1 COLOR

2005

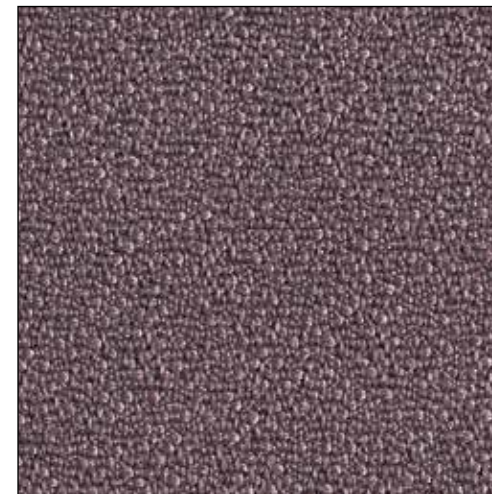

FIBER 1 COLOR

4027



FIBER 1 COLOR

605



FIBER 6 VELVET

606



FIBER 6 VELVET

610



FIBER 6 VELVET

SNOWSOUND FIBER

COLORI TESSUTI - TEXTILES' COLORS - COULEURS TISSUS -
COLORES DE TELAS - STOFFFARBEN

603



FIBER 6 VELVET

600



FIBER 6 VELVET

300

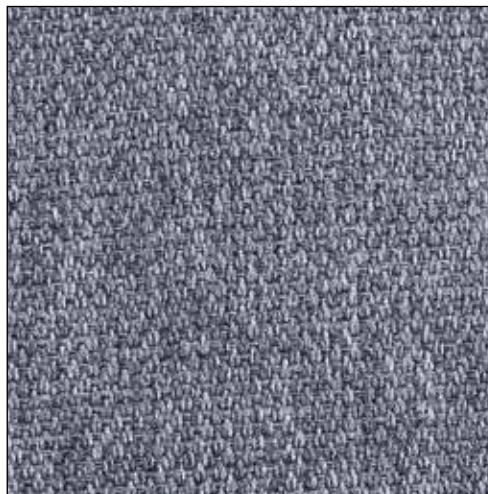

FIBER 3 MELANGE

303

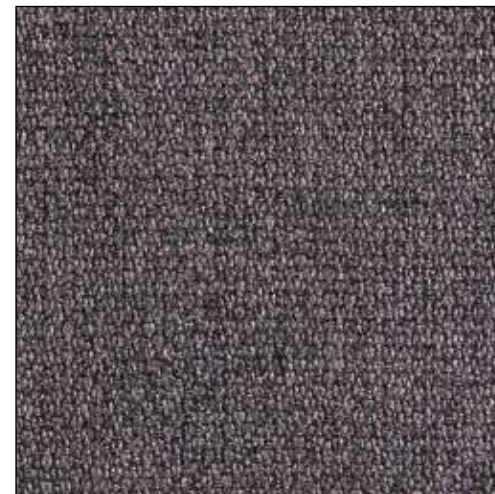

FIBER 3 MELANGE

305



FIBER 3 MELANGE

306



FIBER 3 MELANGE

309

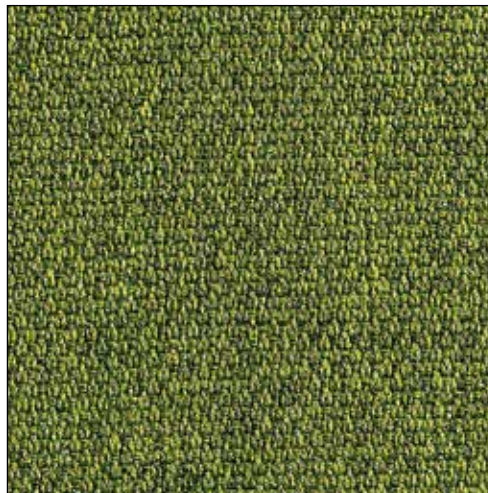

FIBER 3 MELANGE

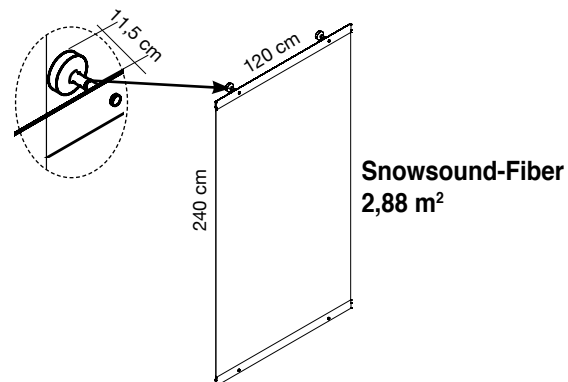
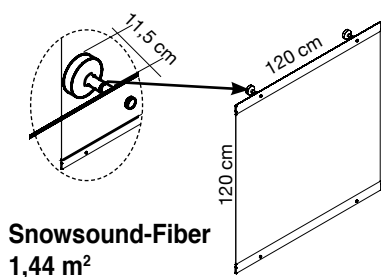

Colore **FIBER 1** Vedi pag. 124
Colour **FIBER 1** See page 124

Codice/Code
Prezzo/Price

Codice/Code
Prezzo/Price

Bianco
White
Blanc

0001

7SFA1212-0001

7SFA1224-0001

Grigio argento
Silver grey
Gris argenté

8004

7SFA1212-8004

7SFA1224-8004

Beige
Beige
Beige

1008

7SFA1212-1008

7SFA1224-1008

Tortora
Dove-grey
Taupe

2005

7SFA1212-2005

7SFA1224-2005

Rosso
Red
Rouge

4027

7SFA1212-4027

7SFA1224-4027

Pannello in poliester **Snowsound-Fiber 1 Color**, cuciture in filo di poliester, dotato di una barra superiore di sostegno e di una barra inferiore entrambe in alluminio verniciato. Completo di quattro bottoni a vista in metallo galvanizzato. Il pannello può essere asportato per consentirne il lavaggio. Attacchi a parete in zama e acciaio galvanizzato completi di molle elastiche in acciaio inox.

Panel made of **Snowsound-Fiber 1 Color** polyester, stitching in polyester thread, equipped with a top support bar and a lower bar, both in epoxy powder-coated aluminum. Complete with four visible buttons in galvanized metal. The panel can be removed to allow for cleaning. Wall mounts in zamak and galvanized steel complete with elastic springs in stainless steel.

Panneau en polyester **Snowsound-Fiber 1 Color**, coutures en fil de polyester, avec une tige supérieure de soutien et une tige inférieure en aluminium peint. Fourni avec 4 boutons en métal galvanisé. Le panneau peut être emporté pour le nettoyage. Fixations au mur en zamak et acier galvanisé avec ressorts élastiques en acier inox.

Panel de poliéster **Snowsound-Fiber 1 Color**, costuras de hilo de poliéster, equipado con barra de soporte superior, y barra de soporte inferior ambas de aluminio pintado. Completo con cuatro botones visibles en metal galvanizado. El panel puede ser removido para permitir el lavado. Soportes de pared de zamak y acero galvanizado completo con muelles elásticas de acero inoxidable.

Panel aus **Snowsound-Fiber 1 Color** Polyester mit Nähten aus Polyester-Faden. Das Paneel ist mit einer oberen und einer unteren lackierten Aluminium-Stütztange versehen. Mit vier sichtbaren galvanisierten Metallknöpfen ausgestattet. Das Paneel kann zur Reinigung entfernt werden. Wandhalterungen aus Zamak und galvanisiertem Stahl, die mit elastischen Edelstahl-Federn ausgestattet sind.



ANDAMENTO DELL'AREA DI ASSORBIMENTO ACUSTICO EQUIVALENTE Aobj PER TERZI D'OTTAVA
 ONE-THIRD-OCTAVE EQUIVALENT SOUND ABSORPTION AREA Aobj CURVE

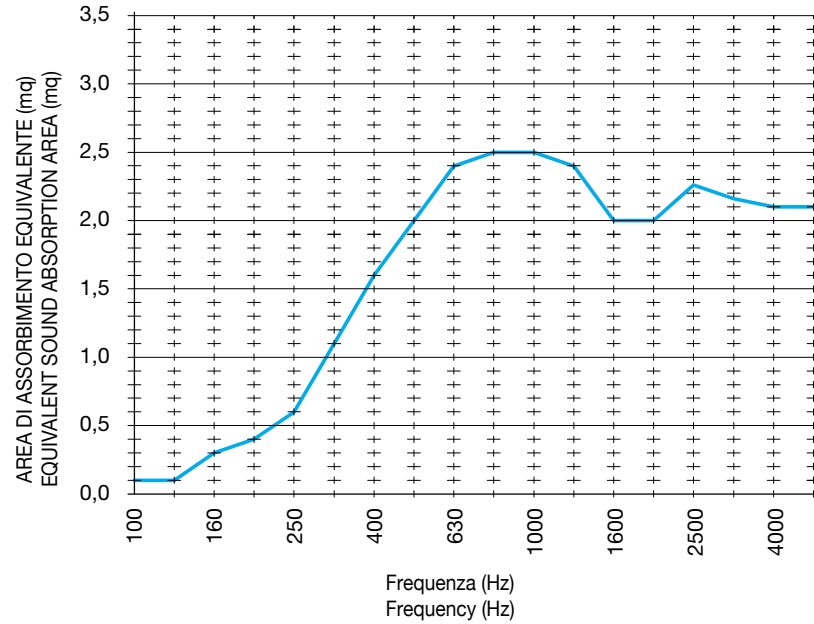

Norma / Standard UNI EN ISO 354

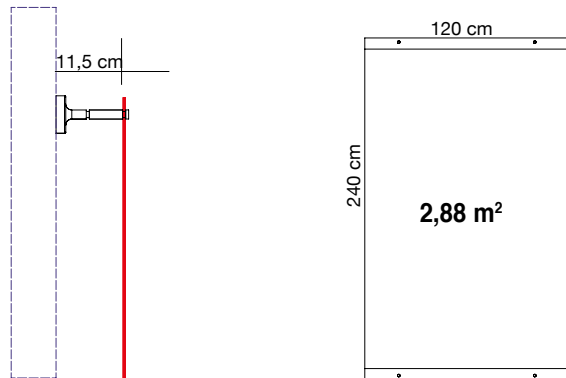

ANDAMENTO DELL'AREA DI ASSORBIMENTO ACUSTICO EQUIVALENTE Aobj PER TERZI D'OTTAVA
 ONE-THIRD-OCTAVE EQUIVALENT SOUND ABSORPTION AREA Aobj CURVE

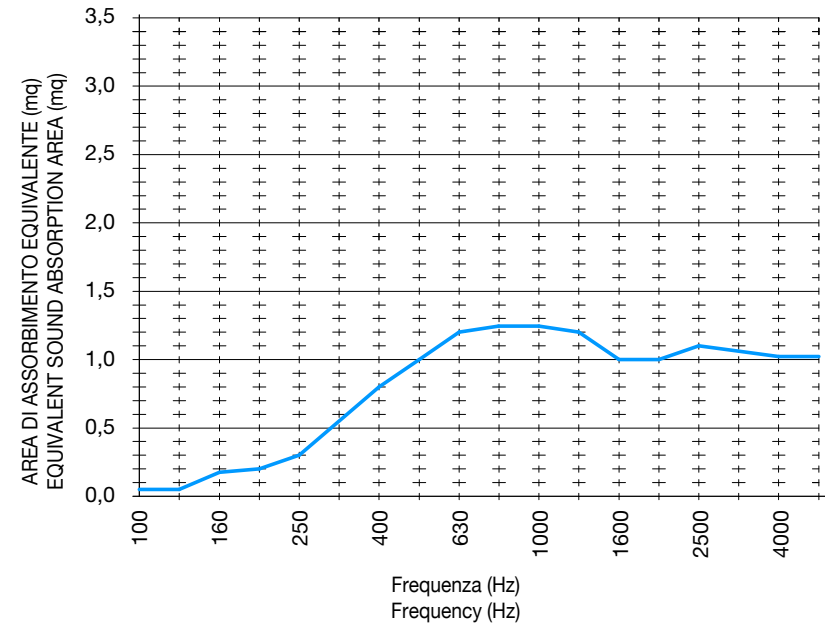

Norma / Standard UNI EN ISO 354

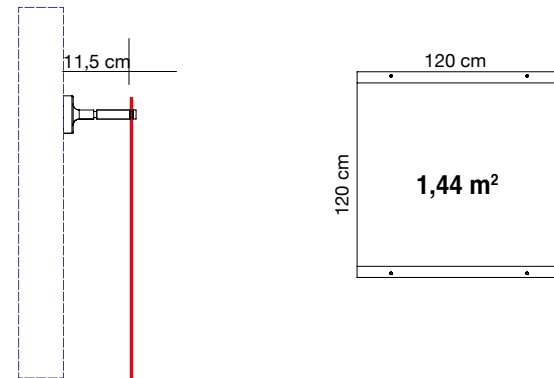

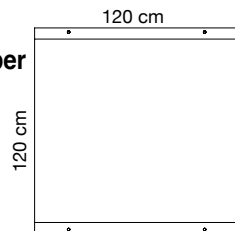
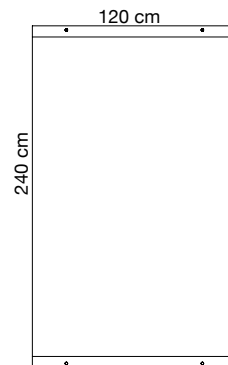
Snowsound-Fiber
1,44 m²FIBER
Vedi pag. 124
See page 124Snowsound-Fiber
2,88 m²Colore FIBER 1 Vedi pag. 124
Colour FIBER 1 See page 124Codice/Code
Prezzo/PriceCodice/Code
Prezzo/PriceBianco
White
Blanc 0001

7SFAP1212-0001

7SFAP1224-0001

Grigio argento
Silver grey
Gris argenté 8004

7SFAP1212-8004

7SFAP1224-8004

Beige
Beige
Beige 1008

7SFAP1212-1008

7SFAP1224-1008

Tortora
Dove-grey
Taupe 2005

7SFAP1212-2005

7SFAP1224-2005

Rosso
Red
Rouge 4027

7SFAP1212-4027

7SFAP1224-4027

Pannello in poliester **Snowsound-Fiber 1 Color**, cucitura in filo di poliester, dotato di una barra superiore di sostegno e di una barra inferiore entrambe in alluminio verniciato. Completo di quattro bottoni a vista in metallo galvanizzato. Il pannello può essere asportato per consentirne il lavaggio.

Panel made of **Snowsound-Fiber 1 Color** polyester, stitching in polyester thread, equipped with a top support bar and a lower bar, both in epoxy powder-coated aluminum. Complete with four visible buttons in galvanized metal. The panel can be removed to allow for cleaning.

Panneau en polyester **Snowsound-Fiber 1 Color**, coutures en fil de polyester, avec une tige supérieure de soutien et une tige inférieure en aluminium peint. Fourni avec 4 boutons en métal galvanisé. Le panneau peut être emporté pour le nettoyage.

Panel de poliéster **Snowsound-Fiber 1 Color**, costuras de hilo de poliéster, equipado con barra de soporte superior, y barra de soporte inferior ambas de aluminio pintado. Completo con cuatro botones visibles en metal galvanizado. El panel puede ser removido para permitir el lavado.

Paneel aus **Snowsound-Fiber 1 Color** Polyester mit Nähten aus Polyester-Faden. Das Paneel ist mit einer oberen und einer unteren lackierten Aluminium-Stütztange versehen. Mit vier sichtbaren galvanisierten Metallknöpfen ausgestattet. Das Paneel kann zur Reinigung entfernt werden.

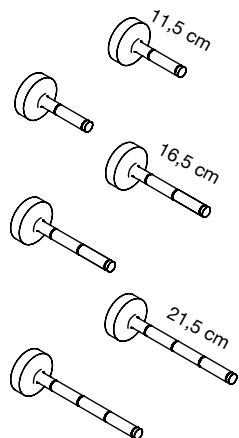

7SFA400-C Cromato/Inox
Chrome-plated
Chromé
Cromado
Verchromt
L. 11,5 cm
1 coppia / 1 pair
1 paire / 1 pare
1 Paar

Attacchi a parete in zama e acciaio galvanizzato completi di molle elastiche in acciaio inox.

Wall mounts in zamak and galvanized steel complete with elastic springs in stainless steel.

7SFA500-C Cromato/Inox
Chrome-plated
Chromé
Cromado
Verchromt
L. 16,5 cm
1 coppia / 1 pair
1 paire / 1 pare
1 Paar

Fixations au mur en zamak et acier galvanisé avec ressorts élastiques en acier inox.

Soportes de pared de zamak y acero galvanizado completo con muelles elásticas de acero inoxidable.

7SFA600-C Cromato/Inox
Chrome-plated
Chromé
Cromado
Verchromt
L. 21,5 cm
1 coppia / 1 pair
1 paire / 1 pare
1 Paar

Wandhalterungen aus Zamak und galvanisiertem Stahl, die mit elastischen Edelstahl-Federn ausgestattet sind.

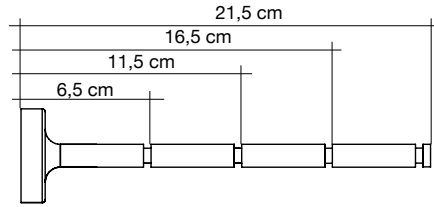
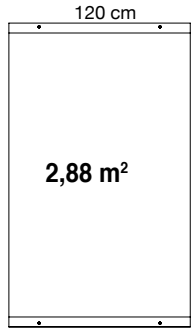

ANDAMENTO DELL'AREA DI ASSORBIMENTO ACUSTICO EQUIVALENTE Aobj
 PER TERZI D'OTTAVA
 ONE-THIRD-OCTAVE EQUIVALENT SOUND ABSORPTION AREA Aobj CURVE

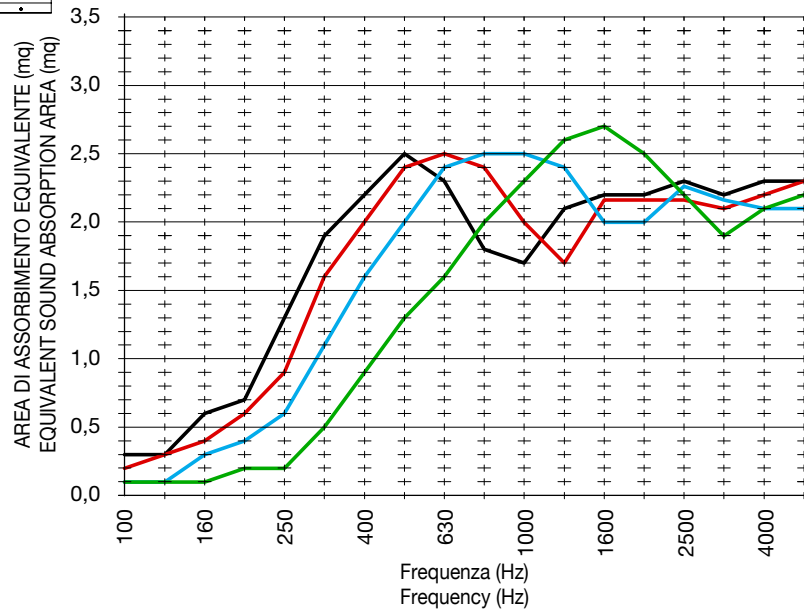

Norma / Standard UNI EN ISO 354

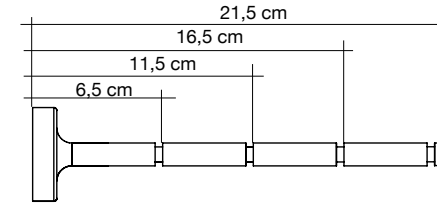
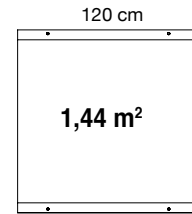
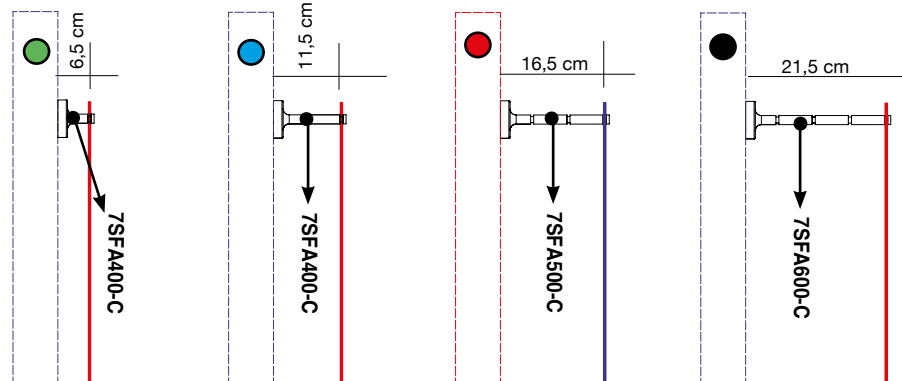

ANDAMENTO DELL'AREA DI ASSORBIMENTO ACUSTICO EQUIVALENTE Aobj
 PER TERZI D'OTTAVA
 ONE-THIRD-OCTAVE EQUIVALENT SOUND ABSORPTION AREA Aobj CURVE

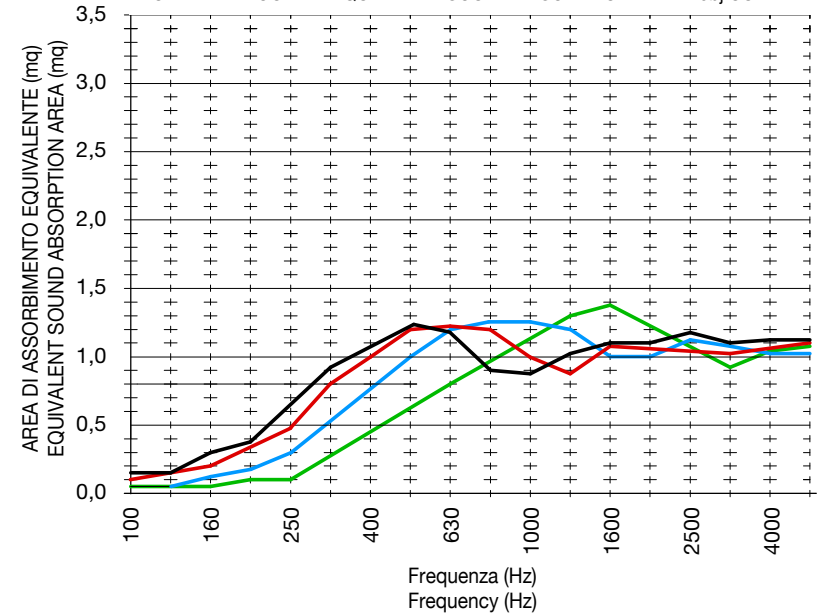

Norma / Standard UNI EN ISO 354

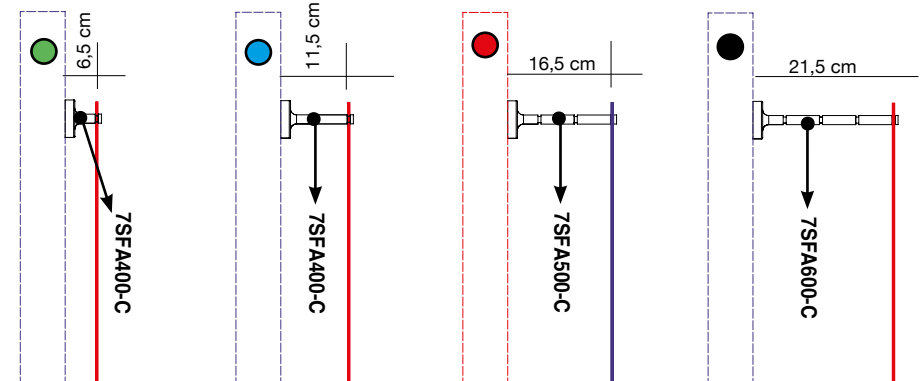

Snowsound-Fiber
0,85 m²

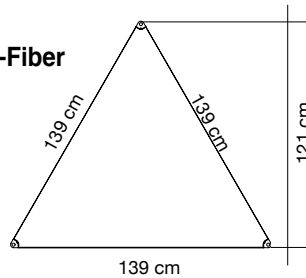

Snowsound-Fiber
2,40 m²

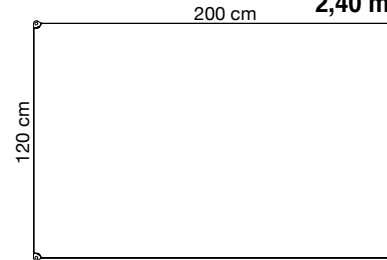

Pannello in poliester **Snowsound-Fiber 1 Color**, cuciture e velcro in poliester. Struttura perimetrale portante in acciaio verniciato dotata di angolari in acciaio inox. Il pannello è applicato alla struttura perimetrale mediante Velcro e può essere asportato per consentirne il lavaggio.

Panel made of **Snowsound-Fiber 1 Color**, polyester stitching and Velcro. Perimeter structure in epoxy powder-coated steel with stainless steel angulars. The panel is applied to the perimeter structure by Velcro and can be removed to allow for cleaning.

Panneau en polyester **Snowsound-Fiber 1 Color**, coutures et velcro en polyester. Structure périmétrale portante en acier peint, avec cornières en acier inox.

Le panneau est appliqué à la structure périmétrale par du Velcro et peut être emporté pour le nettoyage.

Panel de poliéster **Snowsound-Fiber 1 Color**, costuras y velcro de poliéster. Estructura perimetral de acero pintado equipada con ángulos de acero inoxidable.

El panel se aplica a la estructura externa por Velcro y se puede quitar para poder limpiarse fácilmente.

Paneel aus **Snowsound-Fiber 1 Color** Polyester, Nähte und Klettverschluss aus Polyester. Tragende Rahmenstruktur aus lackiertem Stahl mit Edelstahl-Winkelprofilen. Das Paneel ist durch einen Klettverschluss an die Rahmenstruktur befestigt, damit es entfernt und gereinigt werden kann.

Colore **FIBER 1 Vedi pag. 124**
Colour **FIBER 1 See page 124**

Codice/Code
Prezzo/Price

Codice/Code
Prezzo/Price

Bianco
White
Blanc

0001

7SFMT140-0001

7SFMR1220-0001

Grigio argento
Silver grey
Gris argenté

8004

7SFMT140-8004

7SFMR1220-8004

Beige
Beige
Beige

1008

7SFMT140-1008

7SFMR1220-1008

Tortora
Dove-grey
Taupe

2005

7SFMT140-2005

7SFMR1220-2005

Rosso
Red
Rouge

4027

7SFMT140-4027

7SFMR1220-4027



7SFM100-C
Cromato/Inox
Chrome-plated
Chromé
Cromado
Verchromt

L. 11,5 cm

Attacco a parete in zama e acciaio galvanizzato completo di molle elastiche in acciaio inox.

Wall mount in zamak and galvanized steel complete with elastic springs in stainless steel.

Fixation au mur en zamak et acier galvanisé avec ressorts élastiques en acier inox.

Soporte de pared de zamak y acero galvanizado completo con muelles elásticas de acero inoxidable.

Wandhalterungen aus Zamak und galvanisiertem Stahl, die mit elastischen Edelstahl-Federn ausgestattet sind.

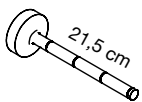

7SFM200-C
Cromato/Inox
Chrome-plated
Chromé
Cromado
Verchromt

L. 21,5 cm

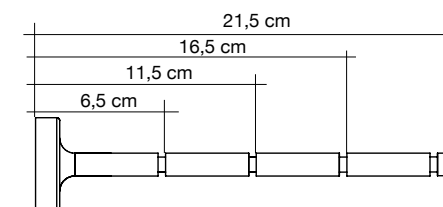

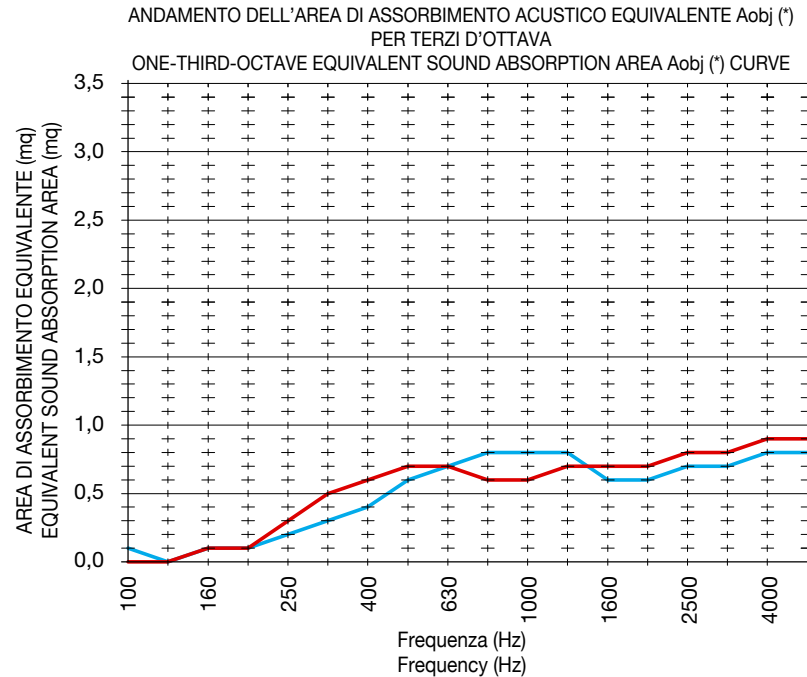

Norma / Standard UNI EN ISO 354

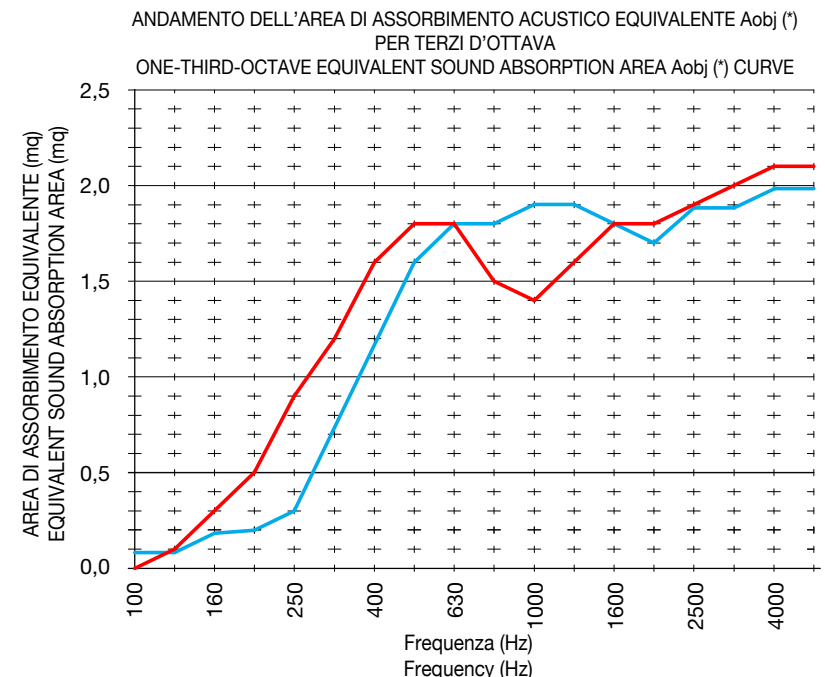
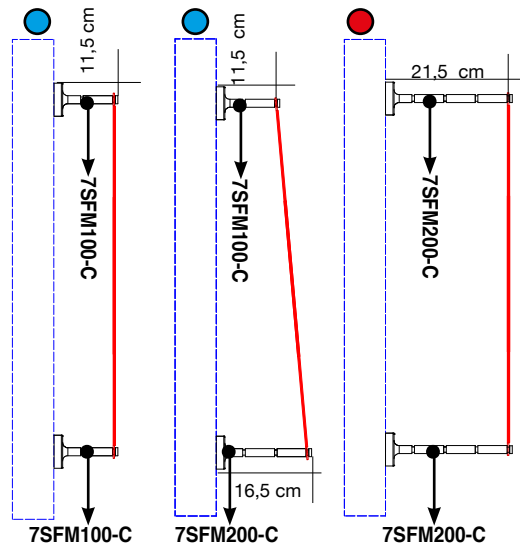
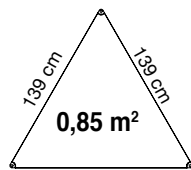

Norma / Standard UNI EN ISO 354

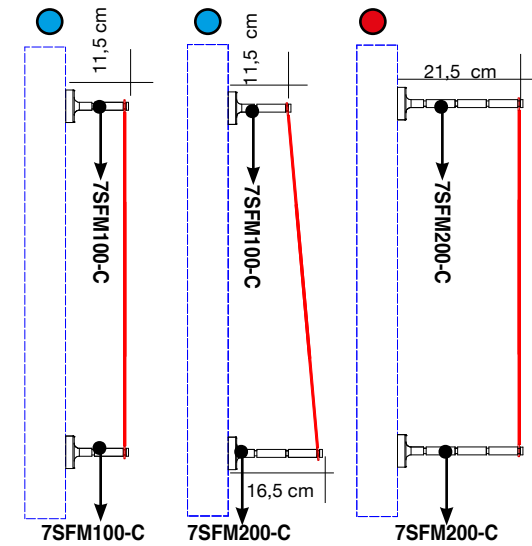
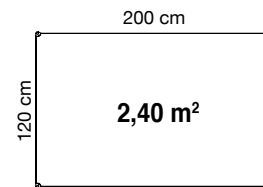

(*) Nel caso di pannelli inclinati, i valori dell' Area di assorbimento equivalente Aobj sono riferiti, in via cautelativa, ai pannelli montati dritti con la minor distanza dal muro.

(*) In case of inclined panels, the values of Equivalent sound absorption area Aobj refer, as a precaution, to panels mounted straight with the shortest distance from the wall.

(*) En cas de panneaux inclinés, les valeurs de la surface d'absorption équivalente Aobj se referent, pour précaution, aux panneaux installés en position droite avec la moindre distance du mur.

(*) En el caso de paneles inclinados, los valores de la área de absorción equivalente Aobj se refieren, como medida de precaución, a los paneles montados directamente con la menor distancia de la pared.

(*) Bei geneigt montierten Paneelen beziehen sich die Werte der äquivalente Absorptionsfläche Aobj vorsichtshalber auf senkrecht mit dem geringstmöglichen Abstand von der Wand montierte Paneele.

Composizione / Composition

6 code 7SFMT140-4027

7 code 7SFM200-C

Snowsound-Fiber 1 Color 5,10 m²**Composizione / Composition**

3 code 7SFMT140-4027

6 code 7SFM200-C

Snowsound-Fiber 1 Color 2,55 m²

Composizione / Composition

6 code 7SFMR1220-4027
2 code 7SFM100-C
10 code 7SFM200-C

Snowsound-Fiber 1 Color 14,40 m²



Composizione / Composition

9 code 7SFMR1220-4027
4 code 7SFM100-C
12 code 7SFM200-C

Snowsound-Fiber 1 Color 21,60 m²

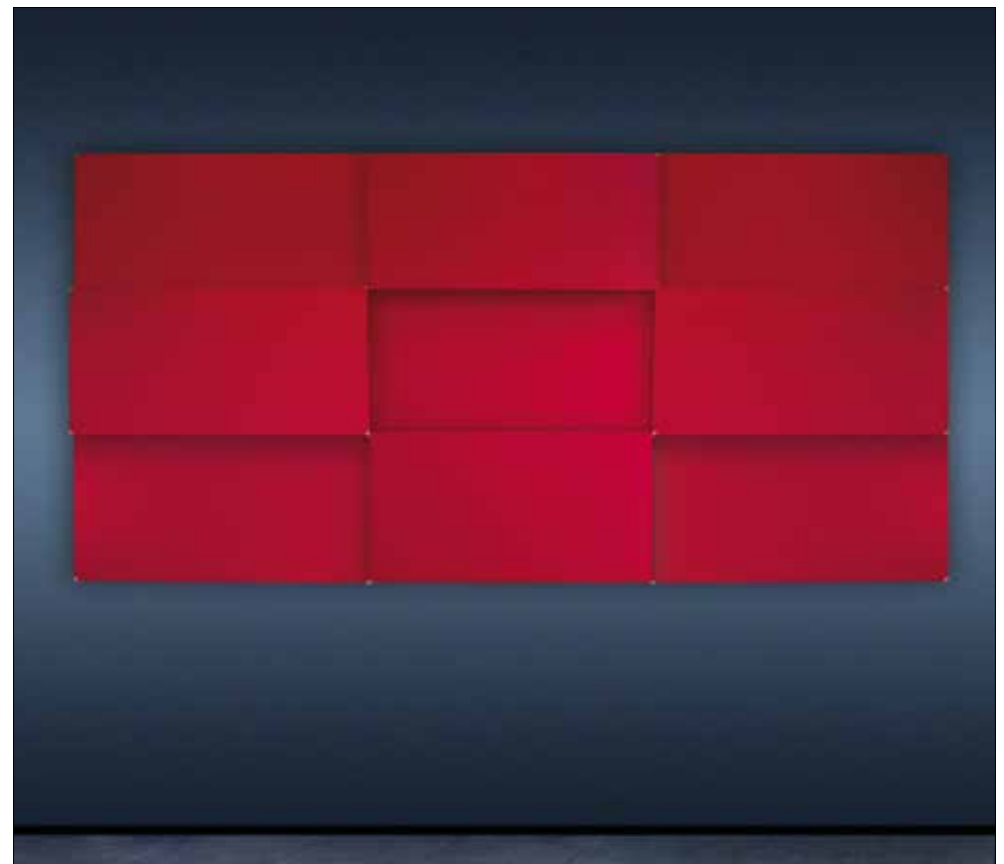

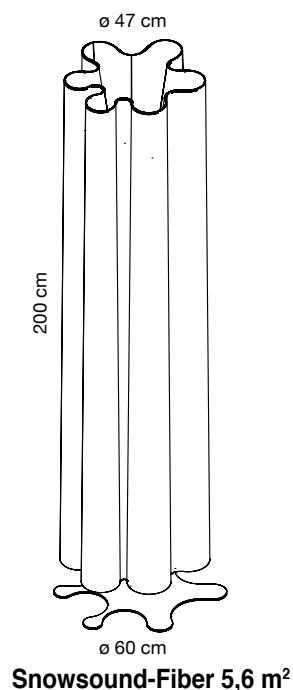

Colore **FIBER 6**
Colour **Vedi pag. 124/125**
See page 124/125



7SFD10N-600



7SFD10N-603



7SFD10N-605



7SFD10N-610

Struttura e base in acciaio verniciato nero.
Panneggio in poliester **Snowsound-Fiber 6 Velvet**, cuciture in filo di poliester.
Il panneggio è applicato alla struttura superiore mediante attacchi removibili in acciaio.

Structure and base in black epoxy powder-coated steel.
Drapery made of **Snowsound-Fiber 6 Velvet** polyester, stitching made of polyester thread.
The drapery is applied to the upper structure through steel removable fixings.

Structure et base en acier peint noir.
Drapérie en polyester **Snowsound-Fiber 6 Velvet**, coutures en fil de polyester.
La drapérie est appliquée à la structure supérieure à l'aide de fixations emportables en acier.

Estructura y base de acero pintado negro.
Pañería de poliéster **Snowsound-Fiber 6 Velvet**, costuras de hilo de poliéster.
La pañería se aplica a la estructura superior a través de ataques de acero extraíbles.

Struktur und Unterbau aus schwarz beschichtetem Stahl.
Drapierung aus **Snowsound-Fiber-6 Velvet**-Polyester, Nähte aus Polyester-Faden.
Die Drapierung wird mithilfe von entfernbaren Stahlhalterungen auf dem oberen Teil der Struktur angebracht.

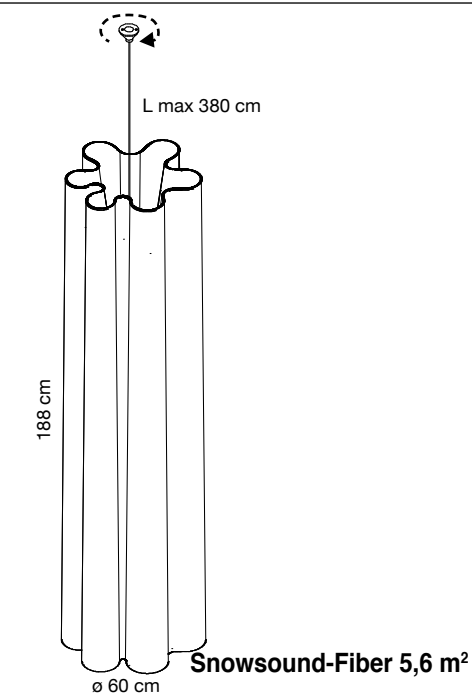

Colore **FIBER 6**
Colour **Vedi pag. 124/125**
See page 124/125



7SFD20-600



7SFD20-603



7SFD20-605



7SFD20-610

Struttura superiore in acciaio verniciato, asta superiore dotata di serracavo in metallo galvanizzato, cavo per l'appendimento in acciaio inox. Attacco a soffitto in metallo dotato di cuscinetto a sfere che consente la rotazione libera dell'intero oggetto.
Panneggio in poliester **Snowsound-Fiber 6 Velvet**, cuciture in filo di poliester. Il panneggio è applicato alla struttura superiore mediante attacchi removibili in acciaio.

Upper structure in epoxy powder-coated steel, top rod with galvanized steel cable clamp, stainless steel wire for hanging. Ceiling attachment equipped with metal ball bearing that allows free rotation of the entire object. Drapery made of **Snowsound-Fiber 6 Velvet** polyester, stitching made of polyester thread. The drapery is applied to the upper structure through steel removable fixings.

Structure supérieure en acier peint, tige supérieure avec serre-câble en métal galvanisé, câble d'accrochage en acier inox. Fixation au plafond en métal avec roulement à billes pour la libre rotation de l'objet entier. Drapérie en polyester **Snowsound-Fiber 6 Velvet**, coutures en fil de polyester. La drapérie est appliquée à la structure supérieure à l'aide de fixations emportables en acier.

Estructura superior de acero pintado, varrilla superior con abrazadera de cable en metal galvanizado, cable para colgar de acero inoxidable. Fijación en el techo de metal equipado con rodamiento de bolas que permite la libre rotación de todo el objeto. Pañería de poliéster **Snowsound-Fiber 6 Velvet**, costuras de hilo de poliéster. La pañería se aplica a la estructura superior a través de ataques de acero extraíbles.

Obere Struktur aus beschichtetem Stahl, obere Stange mit galvanisiertem Metallkabelbinder ausgestattet, Aufhängekabel aus Edelstahl. Deckenhalterung aus Metall mit Kugellager, wodurch die vollständige freie Rotation des Objekts ermöglicht wird. Drapierung aus **Snowsound-Fiber-6 Velvet**-Polyester, Nähte aus Polyester-Faden. Die Drapierung wird mithilfe von entfernbaren Stahlhalterungen auf dem oberen Teil der Struktur angebracht.

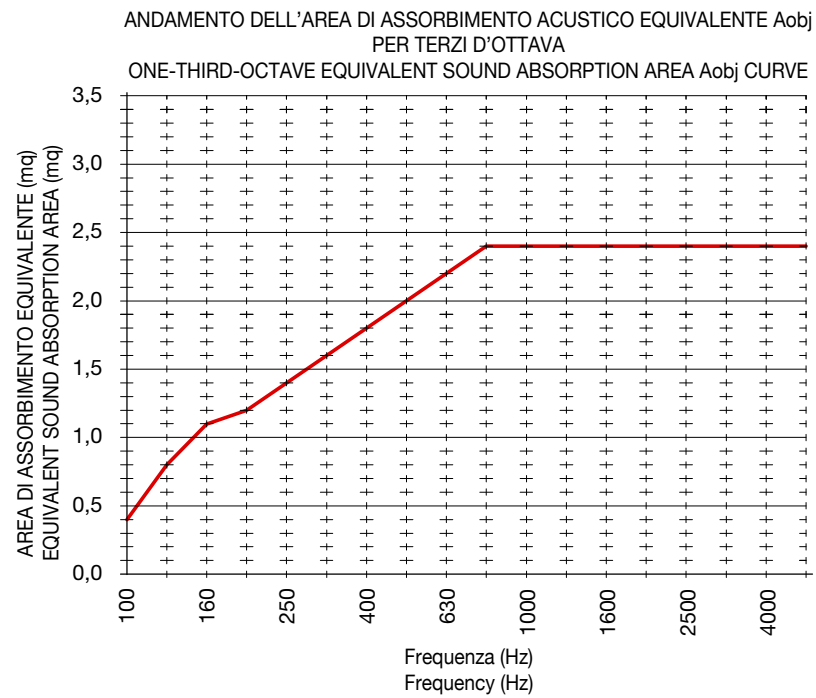

Norma / Standard UNI EN ISO 354

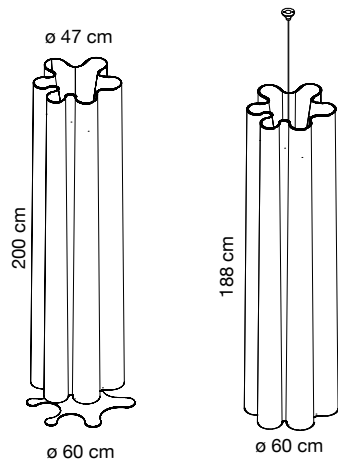

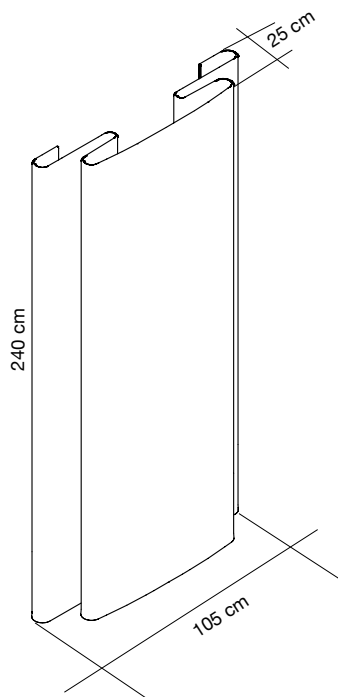
Snowsound-Fiber 6,5 m²

Colore
Colour

FIBER 6

Vedi pag. 124/125

See page 124/125



7SFD30-600



7SFD30-603



7SFD30-605



7SFD30-610

Codice/Code
Prezzo/Price

Struttura in acciaio verniciato nero.

Panneggio in poliestere **Snowsound-Fiber 6 Velvet**, cuciture in filo di poliestere.

Il panneggio è applicato alla struttura superiore mediante attacchi removibili in acciaio.

Structure in black epoxy powder-coated steel.

Drapery made of **Snowsound-Fiber 6 Velvet** polyester, stitching made of polyester thread.

The drapery is applied to the upper structure through steel removable fixings.

Structure en acier peint noir.

Drapérie en polyester **Snowsound-Fiber 6 Velvet**, coutures en fil de polyester.

La drapérie est appliquée à la structure supérieure à l'aide de fixations emportables en acier.

Estructura de acero pintado negro.

Pañería de poliéster **Snowsound-Fiber 6 Velvet**, costuras de hilo de poliéster.

La pañería se aplica a la estructura superior a través de ataques de acero extraíbles.

Struktur aus schwarz beschichtetem Stahl.

Drapierung aus **Snowsound-Fiber-6 Velvet**-Polyester, Nähte aus Polyester-Faden.

Die Drapierung wird mithilfe von entfernbaren Stahlhalterungen auf dem oberen Teil der Struktur angebracht.

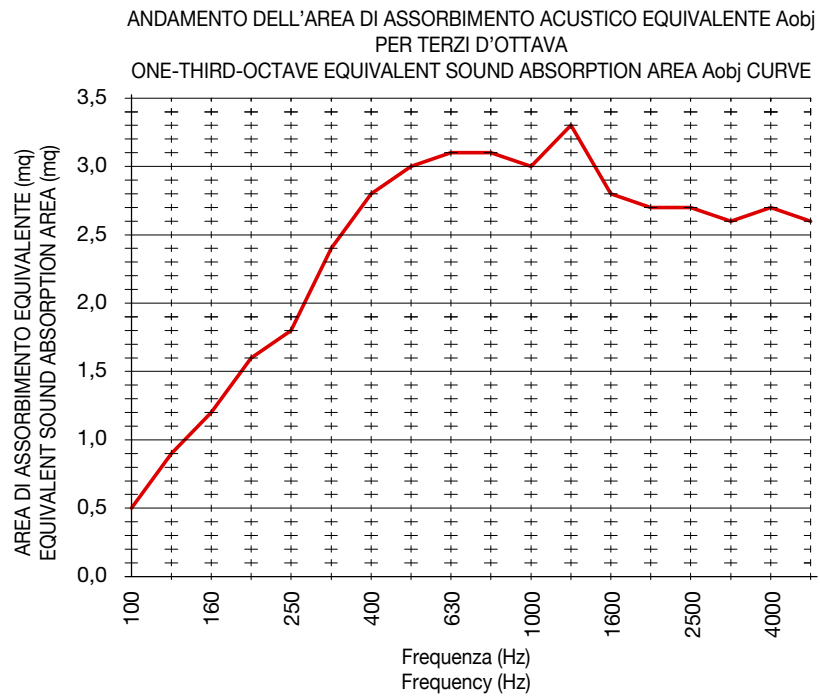

Norma / Standard UNI EN ISO 354

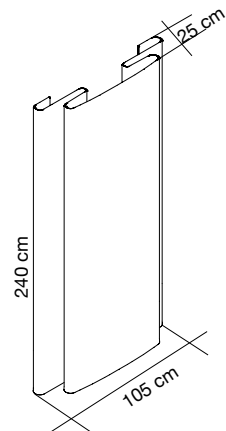

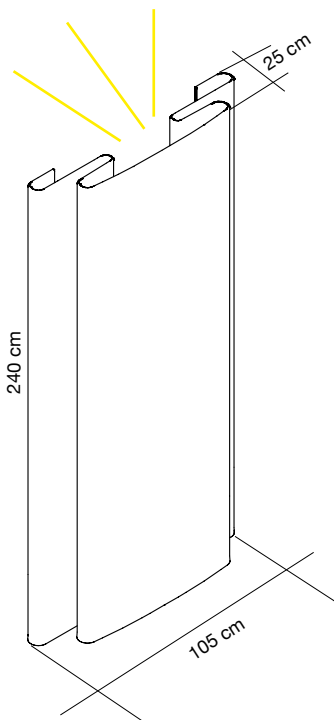
Snowsound-Fiber 6,5 m²

Colore
Colour
FIBER 6
Vedi pag. 124/125
See page 124/125



7SFDL30-600



7SFDL30-603



7SFDL30-605



7SFDL30-610

Codice/Code
Prezzo/Price

Struttura in acciaio verniciato nero.
Panneggio in poliestere **Snowsound-Fiber 6 Velvet**, cuciture in filo di poliestere.
Il panneggio è applicato alla struttura superiore mediante attacchi removibili in acciaio.
Equipaggiata con lampada a LED potenza 25W, 3000K.

Structure in black epoxy powder-coated steel.
Drapery made of **Snowsound-Fiber 6 Velvet** polyester, stitching made of polyester thread.
The drapery is applied to the upper structure through steel removable fixings. Equipped with LED lamp, 25W power, 3000K.

Structure en acier peint noir.
Drapérie en polyester **Snowsound-Fiber 6 Velvet**, coutures en fil de polyester.
La drapérie est appliquée à la structure supérieure à l'aide de fixations emportables en acier. Equipé avec lampe LED 25W, 3000K.

Estructura de acero pintado negro.
Pañería de poliéster **Snowsound-Fiber 6 Velvet**, costuras de hilo de poliéster.
La pañería se aplica a la estructura superior a través de ataques de acero extraíbles.
Equipada con lámpara de LED potencia 25W, 3000K

Struktur aus schwarz beschichtetem Stahl.
Drapierung aus **Snowsound-Fiber-6 Velvet**-Polyester, Nähte aus Polyester-Faden.
Die Drapierung wird mithilfe von entfernbaren Stahlhalterungen auf dem oberen Teil der Struktur angebracht. Mit LED-Lampe (25W, 3000K) ausgestattet

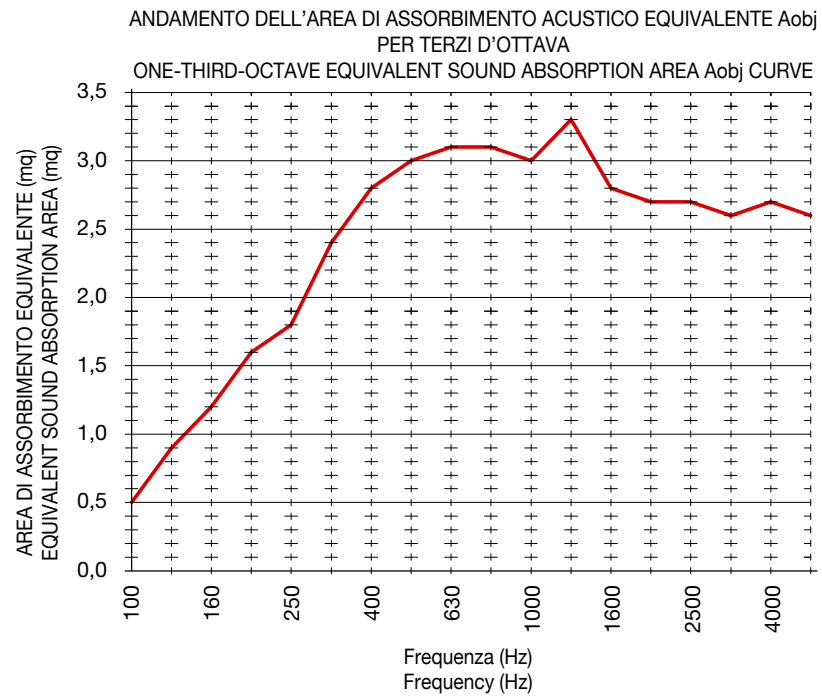

Norma / Standard UNI EN ISO 354

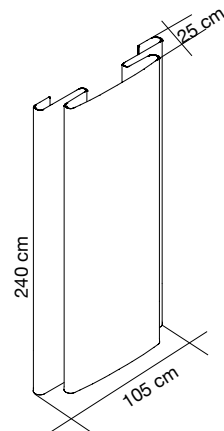

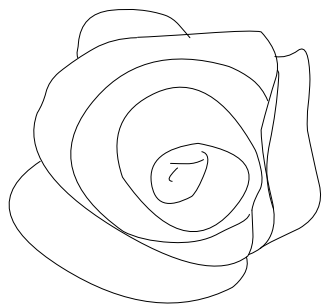

ø ~ 80 cm

Snowsound-Fiber 5 m²

Fatto a mano
Handmade

Colore **FIBER 6**
Colour **Vedi pag. 124/125**
See page 124/125

Codice/Code
Prezzo/Price



7SIW80-600



7SIW80-603



7SIW80-605



7SIW80-606



7SIW80-610

ANDAMENTO DELL'AREA DI ASSORBIMENTO ACUSTICO EQUIVALENTE Aobj
PER TERZI D'OTTAVA

ONE-THIRD-OCTAVE EQUIVALENT SOUND ABSORPTION AREA Aobj CURVE

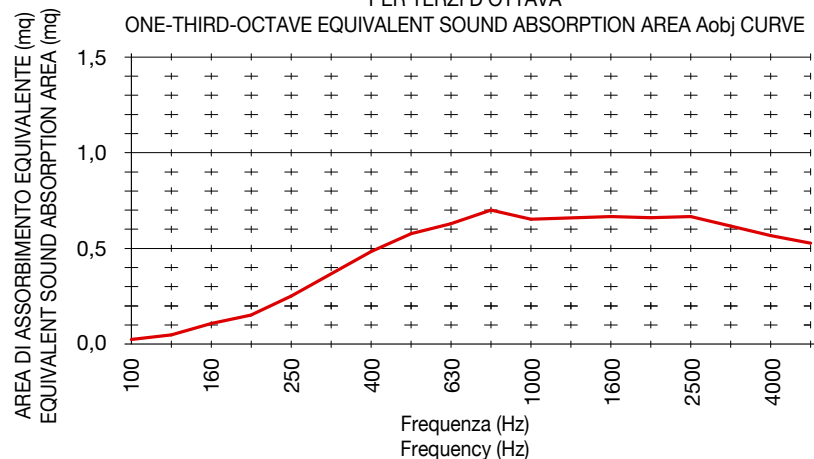

Norma / Standard **UNI EN ISO 354**

Oggetto decorativo acustico fonoassorbente realizzato con tessuti in poliestere **Snowsound-Fiber 6 Velvet**. Anima centrale in conglomerato ligneo. Fissaggio a parete (viti non incluse)

Sound absorbing acoustic decorative object made of **Snowsound-Fiber 6 Velvet** polyester fabric. Central core in wood conglomerate. Wall mounting (screws not included).

Objet décoratif phono-absorbant en tissu de polyester **Snowsound-Fiber 6 Velvet**. Noyau central en conglomerat de bois. Pour fixation murale (vis pas fournies)

Objeto decorativo acústico fonoabsorbente que se realizó con tela de poliéster **Snowsound-Fiber 6 Velvet**. Bastidor central de aglomerado de madera. Fijación mural (tornillos no incluidos)

Schalldämpfendes Dekor-Objekt aus Polyester-Gewebe **Snowsound-Fiber 6 Velvet**. Zentrales Gestell aus Holzkonglomerat. Wandbefestigung (Schrauben nicht mitgeliefert)

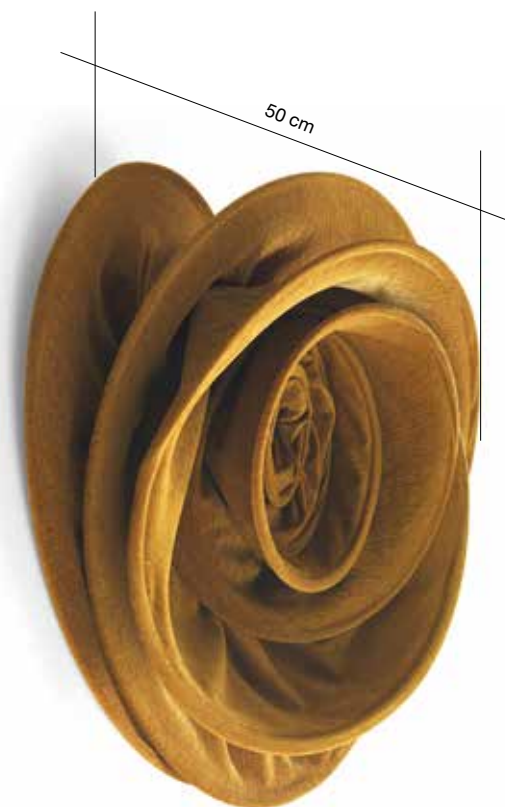

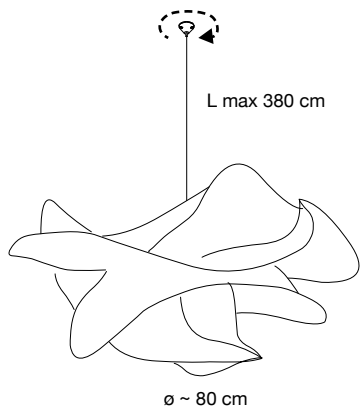

Snowsound-Fiber 5 m²

**Fatto a mano
 Handmade**

Colore **FIBER 6**
 Colour **Vedi pag. 124/125**
 See page 124/125

Codice/Code
 Prezzo/Price



7SIC80-600



7SIC80-603



7SIC80-605



7SIC80-606



7SIC80-610

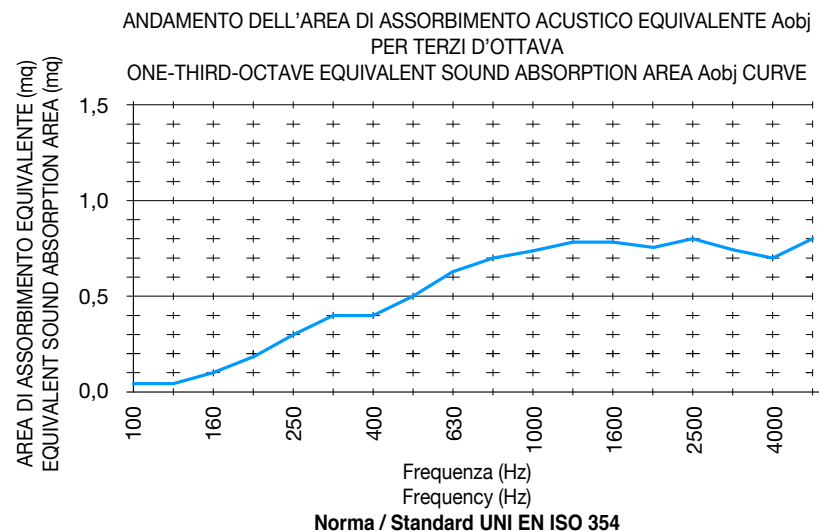

Oggetto decorativo acustico fonoassorbente realizzato con tessuti in poliestere **Snowsound-Fiber 6 Velvet**. Anima centrale in conglomerato ligneo. Completo di cavo e attacco a soffitto in metallo dotato di cuscinetto a sfere che consente la rotazione libera dell'intero oggetto.

Sound absorbing acoustic decorative object made of **Snowsound-Fiber 6 Velvet** polyester fabric. Central core in wood conglomerate. With steel cable and ceiling attachment equipped with metal ball bearing that allows free rotation of the entire object.

Objet décoratif phono-absorbant en tissu de polyester **Snowsound-Fiber 6 Velvet**. Noyau central en conglomerat de bois. Avec câble en acier et fixation au plafond en métal avec roulement à billes pour la libre rotation de l'objet entier.

Objeto decorativo acústico fonoabsorbente que se realizó con tela de poliéster **Snowsound-Fiber 6 Velvet**. Bastidor central de aglomerado de madera. Completo de cable de acero y fijación en el techo de metal equipado con rodamiento de bolas que permite la libre rotación de todo el objeto.

Schalldämpfendes Dekor-Objekt aus Polyester-Gewebe **Snowsound-Fiber 6 Velvet**. Zentrales Gestell aus Holzkonglomerat. Mit Stahlseile und Deckenhalterung aus Metall mit Kugellager, wodurch die vollständige freie Rotation des Objekts ermöglicht wird.



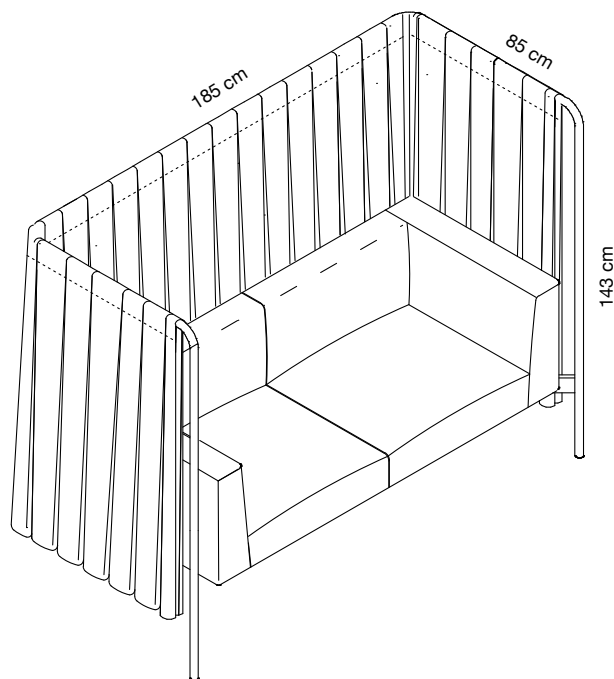

Colore
Colour

FIBER 3
Vedi pag. 125
See page 125



7SO2P-300



7SO2P-303



7SO2P-305

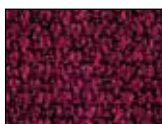

7SO2P-306



7SO2P-309

Codice/Code
Prezzo/Price

Colore
Colour

FIBER 6
Vedi pag. 124/125
See page 124/125



7SO2P-600



7SO2P-603



7SO2P-605



7SO2P-606



7SO2P-610

Codice/Code
Prezzo/Price

Divano acustico a schienale alto realizzato con tessuti in poliester
Snowsound-Fiber 6 Velvet e Fiber 3 Melange
Struttura in tubolare d'acciaio verniciato nero. Fusto in legno multi-
strato e massello, con imbottitura in poliuretano espanso, densità 30
e 40 Kg/m3. **Completamente sfoderabile.**
Il divano è chiuso sui tre lati da pannello in tessuto Snowsound-Fi-
ber 6 Velvet o Fiber 3 Melange arricciato a 6 strati.

Acoustic high back sofa made of **Snowsound-Fiber 6 Velvet** and
Fiber 3 Melange polyester fabric.
Frame in black epoxy-powder coated tubular steel. Multilayer solid
wood frame with polyurethane foam padding, density 30 and 40 Kg/
m3. **Fully removable cover.**
The sofa is closed on three sides by draping Snowsound-Fiber 6 Vel-
vet or Fiber 3 Melange fabric curled with 6 layers.

Divan acoustique avec dossier haut réalisé avec tissus en polyester
Snowsound-Fiber 6 Velvet et Fiber 3 Melange. Structure en tube
d'acier peint noir. Fût en bois feuilleté et massif, avec rembourrage
en expansé, densité 30 et 40 Kg/m3.
Complètement dédoublable.
Le divan est fermé sur trois côtés par un drap en tissu Snow-
sound-Fiber 6 Velvet ou Fiber 3 Melange froncé à 6 couches.

Sofá acústico con respaldo alto que se realizó con tela de poliéster
Snowsound-Fiber 6 Velvet y Fiber 3 Melange. Marco de acero
tubular barnizado negro. Esqueleto de madera multicapa y maciza,
con acolchado de espuma rígida de poliuretano, densidad 30 y 40
Kg/m3. **Completamente desenfundable.**
Los tres costados del sofá están drapeados con tela Snowsound-Fi-
ber 6 Velvet o Fiber 3 Melange fruncida de 6 capas.

Schalldämpf-Sofa mit hoher Lehne, aus Polyesterfaser **Snow-
sound-Fiber 6 Velvet und Fiber 3 Melange** hergestellt. Schwarz
lackiertes Stahlrohr-Gerüst. Gestell aus massivem und Mehr-
schichtholz, Polsterung aus Polyurethan-Hartschaum, Dichte 30 und
40 Kg/m3. **Komplett ausziehbar.**
Das Sofa ist auf drei Seiten mit 6-lagig zusammengefaltetem
Gewebe Snowsound-Fiber 6 Velvet oder Fiber 3 Melange umrahmt.

Snowsound-Fiber 33 m²

Fatto a mano
Handmade

Tempi di consegna 4/6 settimane (mese di agosto escluso)

Lead time 4/6 weeks (month of August excluded)

Délai d'expédition 4/6 semaines (sauf le mois d'Août)

Tiempos de entrega 4/6 semanas (mes de Agosto no incluido)

Lieferzeit 4/6 Wochen (ausgenommen August)

Tutti i colori **Fiber 3 Melange e Fiber 6 Velvet** riportati rispettivamente a pag. 153 e a pag. 155 del presente listino sono disponibili su richiesta

All the colours **Fiber 3 Melange and Fiber 6 Velvet** shown on page 153 and on page 155 of this price list are available on request.

Toutes les couleurs **Fiber 3 Melange et Fiber 6 Velvet** représentées à la page 153 et à la page 155 de cette liste de prix sont disponibles sur demande.

Todos los colores **Fiber 3 Melange y Fiber 6 Velvet** mostrados en la página 153 y en la página 155 de esta lista de precios están disponibles bajo petición.

Alle Farben **Fiber 3 Melange und Fiber 6 Velvet** auf Seite 153 und Seite 155 dieser Preisliste sind auf Anfrage erhältlich.





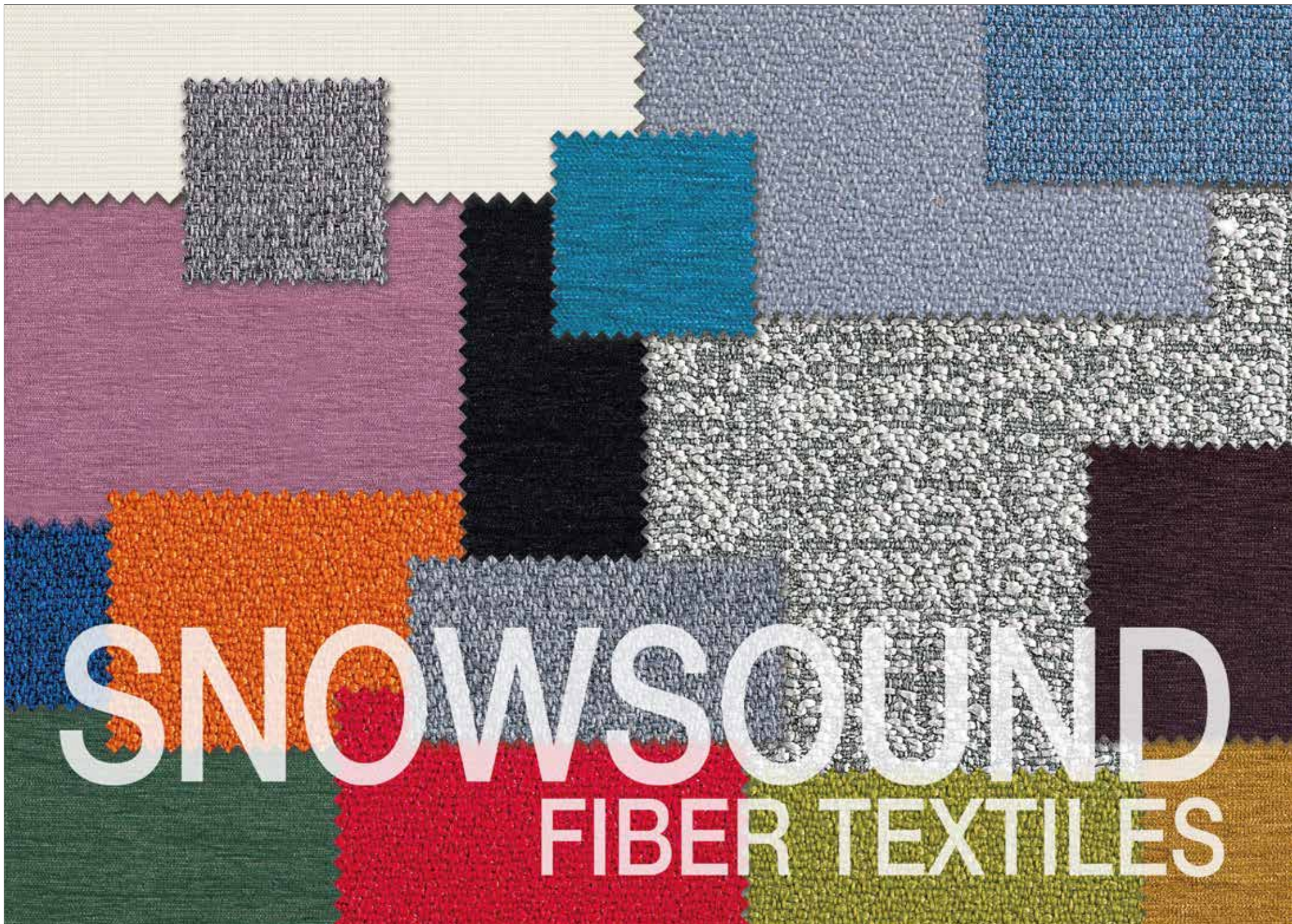

SNOWSOUND FIBER TEXTILES



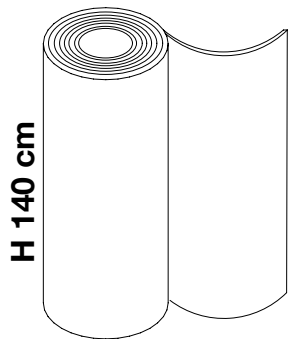

Peso: 510 g/m² - 714 g/metro lineare
 Weight: 510 g/m² - 714 g/linear meter
H = 140 cm (tolleranza / tolerance 0 + 3 cm)

X (min 6 m-max 25 m)



7F1/X-0001



7F1/X-1008



7F1/X-2005

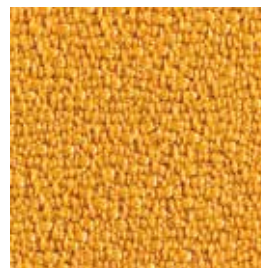

7F1/X-3008



7F1/X-4030

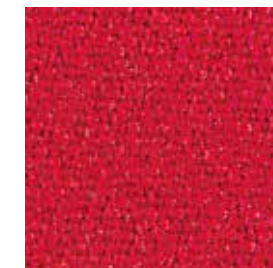

7F1/X-4027



7F1/X-7004



7F1/X-8004

Tempi di consegna 3/4 settimane (mese di agosto escluso)

Lead time 3/4 weeks (month of August excluded)

Délai d'expédition 3/4 semaines (sauf le mois d'Août)

Tiempos de entrega 3/4 semanas (mes de Agosto no incluido)

Lieferzeit 3/4 Wochen (ausgenommen August)

X = lunghezza rotolo, compresa tra 6 e 25 m / X = roll length, between 6 and 25 m / X = longueur du rouleau, comprise entre 6 et 25 m / X = longitud del rollo, entre 6 y 25 m /

X = Rollenlänge, zwischen 6 und 25 m



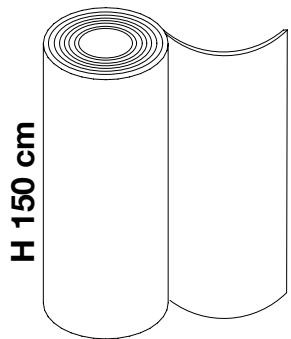

Peso: 222 g/m² - 333 g/metro lineare
 Weight: 222 g/m² - 333 g/linear meter

H = 150 cm (tolleranza / tolerance 0 + 3 cm)

X (min 6 m-max 25 m)



7F2/X-200



7F2/X-201



7F2/X-202

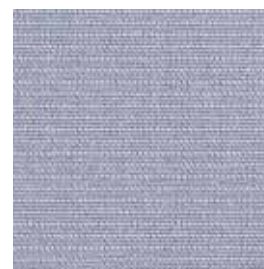

7F2/X-203

Tempi di consegna 3/4 settimane (mese di agosto escluso)

Lead time 3/4 weeks (month of August excluded)

Délai d'expédition 3/4 semaines (sauf le mois d'Août)

Tiempos de entrega 3/4 semanas (mes de Agosto no incluido)

Lieferzeit 3/4 Wochen (ausgenommen August)

X = lunghezza rotolo, compresa tra 6 e 25 m / **X** = roll length, between 6 and 25 m / **X** = longueur du rouleau, comprise entre 6 et 25 m / **X** = longitud del rollo, entre 6 y 25 m /

X = Rollenlänge, zwischen 6 und 25 m



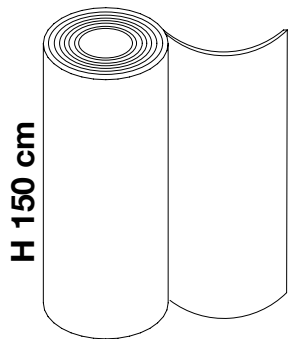

Peso: 222 g/m² - 333 g/metro lineare
Weight: 222 g/m² - 333 g/linear meter

H = 150 cm (tolleranza / tolerance 0 + 3 cm)

X (min 6 m-max 25 m)



7F2R/X-200

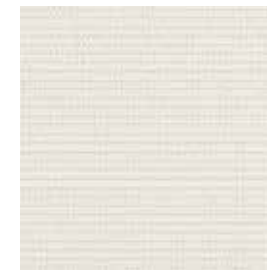

7F2R/X-201



7F2R/X-202

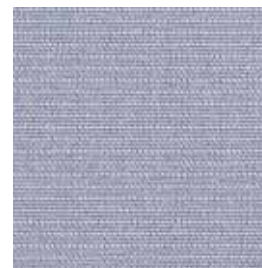

7F2R/X-203

Tempi di consegna 3/4 settimane (mese di agosto escluso)

Lead time 3/4 weeks (month of August excluded)

Délai d'expédition 3/4 semaines (sauf le mois d'Août)

Tiempos de entrega 3/4 semanas (mes de Agosto no incluido)

Lieferzeit 3/4 Wochen (ausgenommen August)

X = lunghezza rotolo, compresa tra 6 e 25 m / **X** = roll length, between 6 and 25 m / **X** = longueur du rouleau, comprise entre 6 et 25 m / **X** = longitud del rollo, entre 6 y 25 m /

X = Rollenlänge, zwischen 6 und 25 m



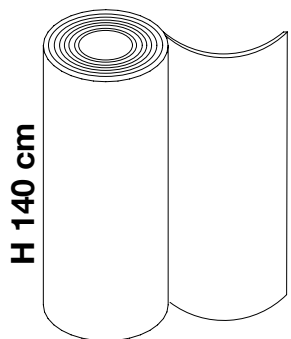

H 140 cm

Peso: 340 g/m² - 476 g/metro lineare
 Weight: 340 g/m² - 476 g/linear meter

H = 140 cm (tolleranza / tolerance 0 + 3 cm)

X (min 6 m-max 25 m)

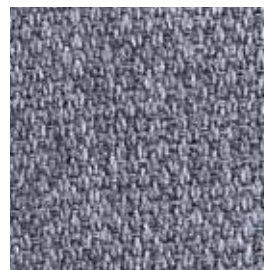

7F3/X-300

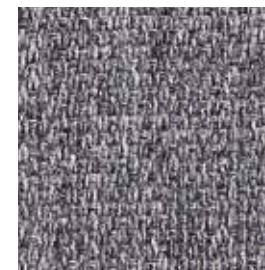

7F3/X-304



7F3/X-303



7F3/X-305



7F3/X-306



7F3/X-307



7F3/X-308

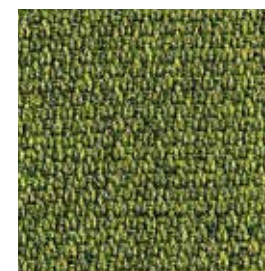

7F3/X-309



7F3/X-310



7F3/X-302

Tempi di consegna 3/4 settimane (mese di agosto escluso)

Lead time 3/4 weeks (month of August excluded)

Délai d'expédition 3/4 semaines (sauf le mois d'Août)

Tiempos de entrega 3/4 semanas (mes de Agosto no incluido)

Lieferzeit 3/4 Wochen (ausgenommen August)

X = lunghezza rotolo, compresa tra 6 e 25 m / **X** = roll length, between 6 and 25 m / **X** = longueur du rouleau, comprise entre 6 et 25 m / **X** = longitud del rollo, entre 6 y 25 m / **X** = Rollenlänge, zwischen 6 und 25 m



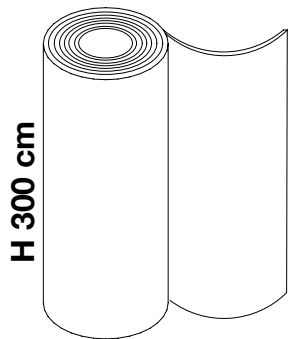

H 300 cm

Peso: 425 g/m² - 1275 g/metro lineare
Weight: 425 g/m² - 1275 g/linear meter

H = 300 cm (tolleranza / tolerance 0 + 3 cm)

X (min 6 m-max 25 m)



7F6/X-600



7F6/X-604



7F6/X-608



7F6/X-601

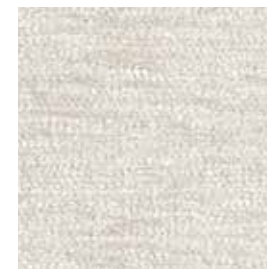

7F6/X-605

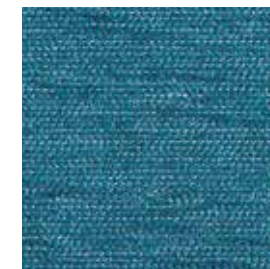

7F6/X-609



7F6/X-602



7F6/X-606



7F6/X-610

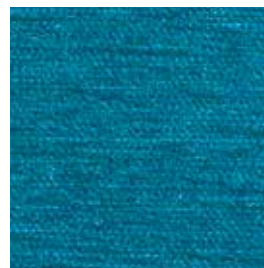

7F6/X-603



7F6/X-607

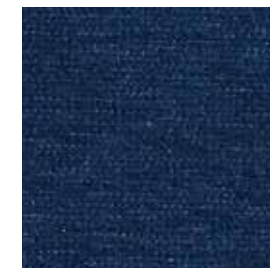

7F6/X-611

Tempi di consegna 3/4 settimane (mese di agosto escluso)

Lead time 3/4 weeks (month of August excluded)

Délai d'expédition 3/4 semaines (sauf le mois d'Août)

Tiempos de entrega 3/4 semanas (mes de Agosto no incluido)

Lieferzeit 3/4 Wochen (ausgenommen August)

X = lunghezza rotolo, compresa tra 6 e 25 m / **X** = roll lenght, between 6 and 25 m / **X** = longueur du rouleau, comprise entre 6 et 25 m / **X** = longitud del rollo, entre 6 y 25 m / **X** = Rollenlänge, zwischen 6 und 25 m



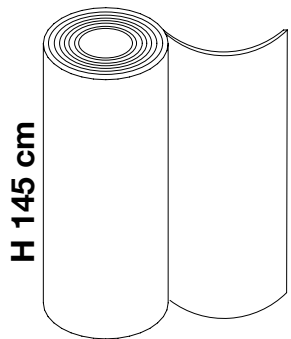

Peso: 460 g/m² - 667 g/metro lineare
 Weight: 460 g/m² - 667 g/linear meter

H = 145 cm (tolleranza / tolerance 0 + 3 cm)

X (min 6 m-max 25 m)

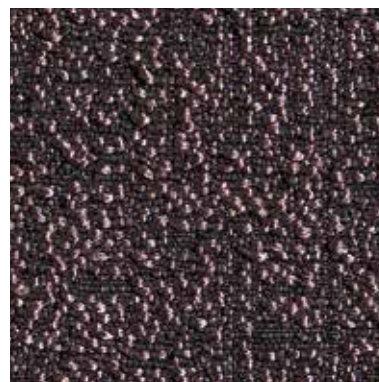

Fronte / Front

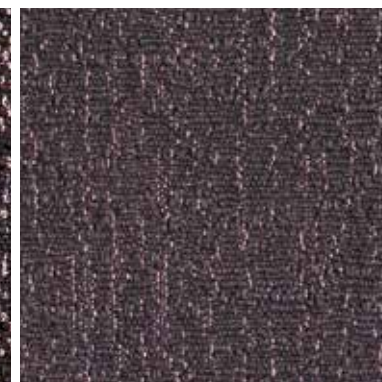

Retro / Back

7F8/X-800

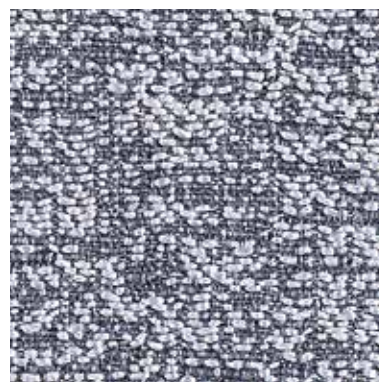

Fronte / Front

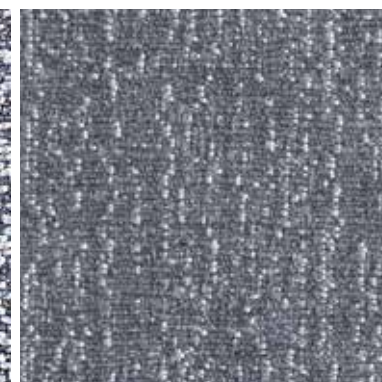

Retro / Back

7F8/X-801

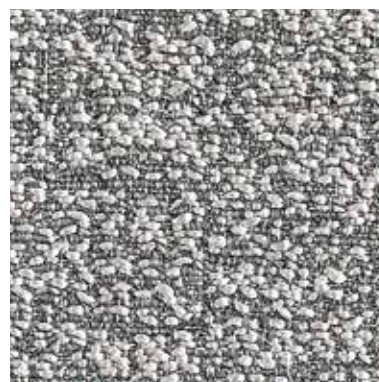

Fronte / Front



Retro / Back

7F8/X-802

Tempi di consegna 3/4 settimane (mese di agosto escluso)

Lead time 3/4 weeks (month of August excluded)

Délai d'expédition 3/4 semaines (sauf le mois d'Août)

Tiempos de entrega 3/4 semanas (mes de Agosto no incluido)

Lieferzeit 3/4 Wochen (ausgenommen August)

X = lunghezza rotolo, compresa tra 6 e 25 m / **X** = roll length, between 6 and 25 m / **X** = longueur du rouleau, comprise entre 6 et 25 m / **X** = longitud del rollo, entre 6 y 25 m / **X** = Rollenlänge, zwischen 6 und 25 m

CONDIZIONI GENERALI DI VENDITA

1. Il presente listino annulla e sostituisce i precedenti e non costituisce offerta.
2. I prezzi dei prodotti possono essere variati dalla venditrice in qualsiasi momento senza preavviso; tutti i prezzi non sono comprensivi di montaggio.
3. La venditrice si riserva la facoltà di modificare, a proprio insindacabile giudizio e senza preavviso alcuno, i materiali costruttivi, le caratteristiche tecniche ed estetiche, nonché le dimensioni dei prodotti.
4. Le immagini dei prodotti sono puramente indicative.
5. La vendita è regolata, oltre che dalle condizioni particolari volta a volta pattuite, dalle presenti condizioni generali, che si reputano conosciute dall'acquirente; eventuali clausole derogatorie a quanto previsto nelle presenti condizioni generali di vendita devono risultare per iscritto.
6. Le proposte d'acquisto e/o gli ordini dell'acquirente sono condizionati all'accettazione espressa o all'inizio dell'esecuzione del contratto da parte della venditrice, nei casi in cui ciò sia consentito. Qualsiasi successiva modifica al contratto di vendita non sarà valida e vincolante ove non risulti da atto scritto e sottoscritto dalla parte nei cui confronti tale modifica viene invocata.
7. Conformemente all'articolo 1510 codice civile, la consegna dei beni venduti si ha con la rimessione degli stessi al vettore o allo spedizioniere, sicché i beni stessi viaggiano a rischio e pericolo dell'acquirente; ciò vale anche nei casi in cui la merce venga venduta franco arrivo all'indirizzo dell'acquirente. Ogni eventuale richiesta, reclamo e/o azione relativi alla spedizione o al trasporto della merce dovrà essere promossa dall'acquirente direttamente nei confronti dello spedizioniere o del vettore. Ogni eventuale danno, perdita o avaria dei beni venduti dipendente dalla spedizione o dal trasporto dei medesimi non esonera l'acquirente dal pagamento del prezzo convenuto.
8. Il termine di consegna è indicativo e non tassativo; lo stesso potrà essere ritardato senza alcun obbligo di indennizzo o risarcimento di eventuali danni diretti o indiretti subiti dall'acquirente per la ritardata consegna e senza che ciò possa comunque comportare la risoluzione del contratto di vendita per inadempimento della venditrice.
9. Fatti salvi i casi di forza maggiore, in caso di scioperi ed in tutti gli altri casi che impediscano temporaneamente alla venditrice di regolarmente adempiere al contratto di vendita, è fatto salvo il diritto della medesima venditrice di recedere dal contratto, senza che l'acquirente sia legittimato ad eventuali pretese di danno, fatta salva nell'ipotesi di recesso la restituzione di quanto eventualmente versato a titolo di acconto.
10. Il pagamento del prezzo di vendita dei prodotti dovrà avvenire presso la sede della venditrice. In caso di pagamento ritardato, l'acquirente sarà automaticamente costituito in mora e sarà tenuto al pagamento degli interessi nella misura e con la decorrenza stabilita dal D.Lgs. 231/2002 per i ritardi di pagamento nelle transazioni commerciali.
11. La venditrice non risponde degli eventuali vizi dei prodotti conosciuti o conoscibili da parte dell'acquirente, che non abbia immediatamente respinto la merce. Le contestazioni od i reclami sulle quantità dei prodotti devono essere segnalate all'atto della consegna, con annotazione sul relativo documento di trasporto. La eventuale sostituzione del prodotto non significa accettazione della contestazione o del reclamo. L'accredito all'acquirente verrà fatto solo dopo la restituzione dei prodotti difettosi ed a condizione che sia stata riconosciuta o altrimenti accertata la responsabilità dalla venditrice.
12. I disegni, i modelli, i grafici e le altre informazioni tecniche dei prodotti oggetto di vendita, così come i campioni, i cataloghi, le fotografie e materiali simili, rimangono sempre di proprietà intellettuale della venditrice e non possono pertanto essere copiati, né trasmessi ad altri, né utilizzati in altro modo.
13. Le somme versate a titolo di caparra confirmatoria potranno essere ritenute dalla venditrice in caso di revoca dell'ordine e/o in ogni altro caso di inadempimento dell'acquirente che giustifichi il recesso della venditrice, salvo il diritto di chiedere l'adempimento del contratto e salvo altresì il diritto di chiedere il risarcimento del maggiore danno. Per converso, nel caso di adempimento da parte dell'acquirente dei propri obblighi contrattuali, le somme da questi versate a titolo di caparra confirmatoria saranno imputate al pagamento del prezzo; le stesse, così come gli eventuali acconti, saranno comunque infruttifere di interessi.
14. L'eventuale tolleranza di una delle parti di comportamenti dell'altra posti in essere in violazione delle clausole che regolano la vendita non costituisce rinuncia ai diritti derivanti dalle clausole violate né al diritto di esigere l'esatto adempimento di tutti i termini e condizioni previsti dal contratto di vendita.
15. La venditrice mantiene la proprietà dei prodotti consegnati fino al completo pagamento del prezzo indicato in fattura. Fino a tale data i prodotti consegnati sono considerati solo come depositati presso l'acquirente. Quest'ultimo si accolla quindi il rischio di danni che i prodotti depositati possano subire imputabili a qualsiasi causa.
16. L'acquirente è invitato a prestare particolare attenzione sul fatto che non tutti i prodotti riportati nel presente listino sono compatibili con il mercato statunitense o con quello canadese. Conseguentemente, qualora l'acquirente intendesse utilizzare o esportare detti prodotti negli Stati Uniti d'America e/o, in ogni caso, in qualsiasi altro paese extra UE, è obbligato a preventivamente contattare l'ufficio commerciale della venditrice per avere la conferma che il prodotto interessato risponda a tutti i requisiti tecnici ed agli standard legali previsti a tutela dei consumatori finali del mercato di destino. La venditrice declina ogni responsabilità conseguente alle iniziative assunte dall'acquirente senza essere stata preventivamente informata ed indipendentemente dall'eventuale autorizzazione scritta della venditrice all'esportazione e/o all'uso del prodotto in un paese extra UE.
18. La venditrice garantisce la conformità dei prodotti alle specifiche indicate nella conferma d'ordine, fatte salve le tolleranze ritenute accettabili dalla produzione industriale.
17. L'acquirente è tenuto ad informare i propri clienti e/o gli utilizzatori finali sulle caratteristiche del prodotto al fine di ridurre al minimo il rischio di un uso improprio che potrebbe esporre la venditrice a possibili ragioni di danno. In difetto di tale attività informativa preventiva, l'acquirente esonera espressamente la venditrice da qualsiasi ipotetica responsabilità.
19. La venditrice non garantisce l'idoneità dei prodotti per scopi particolari e/o usi speciali, salvo specifica richiesta dell'acquirente espressamente accettata per iscritto dalla venditrice e riportata nella relativa conferma d'ordine; l'acquirente deve assicurarsi che gli eventuali standard specifici e/o requisiti legali richiesti siano specificati nella relativa conferma d'ordine della venditrice.
20. Le informazioni della venditrice sull'idoneità specifica dei prodotti sono puramente indicative.
21. Eventuali attività di assistenza e/o calcolo effettuate dalla venditrice sui prodotti, sono da considerarsi puramente indicative e non vincolanti costituendo un mero suggerimento sul posizionamento di massima dei prodotti, ogni dato suggerito deve essere in ogni caso verificato compiutamente dall'acquirente; va da sé che trattandosi comunque di meri suggerimenti non vincolanti, la venditrice non si assume alcuna responsabilità sui risultati di tali attività.
22. Poiché le applicazioni dei prodotti fatte dall'acquirente sono fuori dal controllo della venditrice, quest'ultima non è responsabile per l'uso effettivo dei prodotti; la venditrice non è responsabile per eventuali danni e/o perdite derivanti dall'applicazione non corretta o insolita dei prodotti.
23. In considerazione della particolarità dei prodotti Snowsound-Fiber, sebbene la venditrice si sforzi di mantenere alti livelli di qualità, sono da ritenersi accettabili tre difetti ogni 25 metri con altezza del rotolo fino a 150 cm ed il doppio dei difetti per rotolo con altezza superiore ai 280 cm; la venditrice si riserva comunque la facoltà di scontare per ogni difetto riscontrato una quantità di materiale ritenuta idonea a compensare la difettosità accertata. Non sono accettati resi per prodotti e/o pezze tagliati a misura.
24. L'annullamento di un ordine da parte dell'acquirente è consentito solo in casi eccezionali e previo consenso scritto da parte della venditrice.
25. Nel caso di ordini di prodotti e/o colori fuori standard l'acquirente deve acquistare l'intera produzione effettuata appositamente.
26. Salvo diversa pattuizione e salvo il caso di dolo, la responsabilità della venditrice per i prodotti venduti è limitata ad un importo pari a tre volte il valore della conferma d'ordine, anche in caso di colpa grave.
27. Tutte le controversie che dovessero insorgere in relazione alla vendita, suoi atti modificativi ed esecutivi, comprese quelle inerenti alla validità, efficacia, interpretazione, esecuzione e risoluzione del contratto, saranno devolute alla competenza esclusiva del Foro di Milano.
28. In ogni caso, prima di procedere all'acquisto dei prodotti è necessario consultare le condizioni di vendita, le caratteristiche tecniche e le seguenti ulteriori:

AVVERTENZE

- prima di procedere all'installazione dei prodotti è necessario verificare la portanza della parete/pavimento/superficie su cui verranno collocati i prodotti assicurandosi che siano idonei al tipo di utenza e/o di utilizzo a cui sono destinati;
- i prodotti non sono idonei all'uso da parte di bambini;
- i prodotti non sono idonei ad essere utilizzati in ambienti esterni;
- i prodotti applicati a parete/pavimento/superficie prevedono l'installazione con dispositivi di ancoraggio che non compaiono nelle illustrazioni del catalogo;
- i prodotti devono essere montati e/o installati esclusivamente da personale tecnico competente utilizzando strumenti ed attrezzi adatti allo scopo;
- prima di procedere al montaggio ed all'installazione dei prodotti è necessario leggere attentamente le istruzioni allegate ai prodotti, prestando particolare attenzione sia alle avvertenze che ai disegni esplicativi; qualora le istruzioni non fossero allegate contattare l'ufficio tecnico della venditrice;
- per fissare i prodotti a parete/pavimento/superfici, è necessario utilizzare dei dispositivi di fissaggio adeguati ed in grado di resistere alle forze generate; in ogni caso è necessario utilizzare degli elementi di sostegno idonei a reggere ogni singola struttura;
- in caso di installazione non corretta e/o in caso di superamento dei carichi massimi indicati nel presente listino e/o nelle istruzioni allegate ai singoli prodotti, si potrebbe creare una situazione di pericolo, i prodotti potrebbero crollare, cadere e causare danni a cose e/o persone: non superare mai i carichi evidenziati;
- in caso di dubbi sulle modalità di installazione e/o sulla portanza della parete/pavimento/superficie su cui verrà collocato il prodotto non procedere alla installazione;
- attenersi alle istruzioni e alle composizioni riportate nel presente listino; per composizioni differenti e/o per ulteriori informazioni sui prodotti o sulle modalità di installazione degli stessi contattate l'ufficio tecnico della venditrice.
- leggere differenze di colore fra una partita e l'altra sono da considerarsi normali attese le tolleranze ritenute accettabili per la produzione industriale;
- Il testo facente fede è esclusivamente quello in lingua italiana, le traduzioni hanno la finalità esclusiva di semplificarne la lettura.

GENERAL TERMS OF SALE

1. This price list cancels and replaces the previous ones and is not a proposal.
2. The product prices may be changed by the vendor at any moment without prior notice; all prices are not inclusive of installation.
3. The vendor reserves the right to alter the construction materials, the technical and visual characteristics and also the dimensions of the products, at its own unquestionable discretion and without any prior notice.
4. Product images are purely indicative.
5. In addition to the specific terms agreed each time, sale is governed by these general terms, which are considered to be known by the purchaser; any clauses derogating from these general terms of sale must be in writing.
6. The purchaser's purchase proposals and/or orders are conditional upon the vendor expressly accepting or starting fulfilment of the agreement, in cases where this is permitted. Any subsequent amendment to the sales agreement will not be valid and binding unless entered in a written document signed by the party being asked to accept this amendment.
7. In compliance with article 1510 of the Italian Civil Code, delivery of the goods sold is with remittance thereon to the carrier or forwarder, so that the goods travel at the purchaser's risk and danger; this also applies in cases where the goods are sold free to the purchaser's address. Any other request, complaint and/or action relating to shipment or transport of the goods must be brought by the purchaser directly against the forwarder or the carrier. Any damage, loss or breakage of the goods sold which is attributable to shipment or transport thereof will not exempt the purchaser from liability for payment of the agreed price.
8. The delivery time is indicative and not binding; it may be delayed without any obligation of indemnity or compensation of any direct or consequential damages suffered by the purchaser as a result of late delivery and without this leading to termination of the sales agreement due to the vendor's non-fulfilment.
9. With the exception of cases of force majeure, in the case of strikes and all other cases which temporarily prevent the vendor from fulfilling the sales agreement properly, the vendor is entitled to withdraw from the agreement, without the purchaser being entitled to claim any damages, except for the repayment in the case of withdrawal, of any amount paid as an advance.
10. Payment of the sale price of the products must be made at the vendor's registered office. In the case of late payment, the purchaser will automatically be placed in arrears and will be required to pay interest in the amount and from the time required by Legislative Decree 231/2002 for late payment in commercial transactions.
11. The vendor is not liable for any defects of the products known or knowable to the purchaser, who has not immediately refused to accept delivery of the goods. Disputes or complaints over the product quantities must be notified upon delivery, with noting on the relative transport document. Replacement of the product does not signify acceptance of the claim or complaint. The purchaser will only be credited the amount after the faulty products have been returned and provided that the vendor's liability has been recognised or otherwise ascertained.
12. The drawings, models, graphs and other technical information on the products being sold, and also samples, catalogues, photographs and similar materials, always remain the intellectual property of the vendor and may not be copied, or transmitted to others, or used in any other way.
13. The amounts paid by way of a deposit may be withheld by the vendor if the order is cancelled and/or in all other cases of non-fulfilment by the purchaser which justifies the vendor's withdrawal, without prejudice to the right to request fulfilment of the agreement and also the right to demand compensation of greater damages. In contrast, if the purchaser fulfils its contractual obligations, the amounts paid by way of deposit will be allocated to payment of the price; said amounts, and all other advances, will be non-interest-bearing.
14. Any tolerance by one of the parties of the other's conduct which breaches the clauses governing sale does not constitute waiving of the rights deriving from the breached clauses nor the right to demand precise fulfilment of all the terms and conditions contained in the sales agreement.
15. The vendor maintains ownership of the products until complete payment of the price indicated on the invoice. Up until that date, the products delivered are considered as only held in deposit by the purchaser. The latter therefore accepts the risk of damages to the products deposited attributable to any cause.
16. The purchaser is invited to pay particular attention to the fact that not all products on the price list are compatible with the US or Canadian markets. Consequently, if intending to use or export said products into the USA and/or, in any case, into any other non-EU country, the purchaser is required to contact the vendor's sales office beforehand for confirmation that the product concerned satisfies all technical requirements and legal standards protecting final consumers on the market of destination. The vendor declines all liability consequent upon initiatives taken by the purchaser without it having been informed beforehand and irrespective of any written authorisation of the vendor for exportation to and/or use of the product in a non-EU country.
17. The purchaser is required to inform its own customers and/or final users of the product characteristics, in order to reduce to a minimum the risk of improper use which could expose the vendor to possible claims of damage. In the case of failure to provide this prior information, the purchaser expressly exempts the vendor from any hypothetical liability.
18. The seller guarantees the conformity of the products to the specifications indicated in the order confirmation, except for the tolerances considered acceptable in industrial production.
19. The seller does not guarantee the suitability of the products for particular purposes and/or special uses, unless specifically requested by the buyer and expressly accepted in writing by the seller with a statement in the relative order confirmation; the buyer must ensure that any specific standards and/or legal requirements are specified in the relative order confirmation of the seller.
20. The seller's information regarding specific suitability of the products is purely indicative.
21. Any eventual consulting and/or design activity and/or calculation carried out by the seller pertaining products is to be considered purely indicative and represents a simple suggestion concerning products' generic positioning, hence not binding. Each suggested fact must be fully verified by the buyer; the seller assumes no responsibility for the results of such activities.
22. Since the applications of the products made by the buyer are beyond the seller's control, the seller is not responsible for the actual use of the products; the seller is not responsible for any damage and/or loss resulting from incorrect or unusual application of the products.
23. In consideration of the particularity of Snowsound-Fiber products, although the seller strives to maintain high levels of quality, three defects are acceptable every 25 meters on rolls up to 150cm high and twice as many defects per roll with a height of more than 280 cm; the seller reserves the right to discount, for each defect found, a quantity of material considered suitable to compensate for the proven defect. No returns are accepted for products and/or pieces cut to size.
24. Cancellation of an order by the buyer is permitted only in exceptional cases and subject to prior written consent from the seller.
25. In case of orders containing non-standard products and/or colors, the buyer must purchase the entire production carried out specifically for this purpose.
26. Unless otherwise agreed and unless in case of fraud, the seller's liability for the products sold is limited to an amount equal to three times the value of the order confirmation, even in case of severe guilt.
27. Milan Court will be the sole court of competent jurisdiction for all disputes which may arise in relation to sale and any actions of amendment and enforcement thereof, including those relating to the validity, effectiveness, interpretation, fulfilment and termination of the agreement.
28. In any case, before purchasing the products, it is necessary to consult the terms of sale, technical characteristics and furthermore the following:

WARNINGS

- Before installing the products, check the bearing capacity of the wall/floor/surface on which the products will be positioned, ensuring they are suitable for the intended type of user/use.
- The products are not suitable for use by children.
- The products are not suitable for use outside.
- If the products are applied to the wall/floor/surface, they must be installed with anchoring devices (not shown in the catalogue).
- The products must be assembled and/or installed exclusively by skilled technical personnel, using instruments and tools appropriate for this purpose.
- Carefully read the instructions enclosed with the product before proceeding with assembly and installation, paying particular attention to the warnings and to the explanatory drawings; if the instructions are not attached, contact the vendor's technical office.
- Suitable attachment devices must be used to attach the products to the wall/floor/surfaces, which are strong enough to resist the forces generated; in any case, suitable supporting elements to support each individual element must be used.
- In the case of incorrect installation and/or weights exceeding the maximum loads indicated on this price list and/or the instructions attached to the individual products, a situation of danger could be created, the products could collapse, fall and cause damage to people and/or things: never exceed the loads indicated.
- Do not install the product in the case of any doubts over the methods of installation and/or bearing capacity of the wall/floor/surface on which the product is to be positioned.
- Comply with the instructions and compositions shown on this price list; for different compositions and/or further information on the products or installation methods, contact the vendor's technical office.
- Slight color differences between one lot and another have to be considered normal, within usual tolerances usually accepted for industrial productions.
- The authentic text is only in Italian, the translation has the mere purpose of simplifying the reading.

CONDITIONS GÉNÉRALES DE VENTE

1. Le présent catalogue des prix annule et remplace les précédents et ne constitue pas une offre.
2. Les prix des produits peuvent être changés par la venderesse à tout moment sans préavis; aucun prix ne comprend le montage.
3. La venderesse se réserve le droit de modifier, selon sa décision sans appel et sans aucun préavis, les matériaux servant à la construction, les caractéristiques techniques et esthétiques ainsi que les dimensions des produits.
4. Les images des produits sont fournies à titre purement indicatif.
5. La vente est réglementée, en plus des conditions particulières convenues à chaque fois, par les présentes conditions générales, qui sont considérées comme connues par l'acheteur; d'éventuelles clauses dérogatoires aux dispositions des présentes conditions générales de vente doivent être mises par écrit.
6. Les offres d'achat et/ou commandes de l'acheteur sont soumises à l'acceptation explicite ou au début de l'exécution du contrat par la venderesse, dans les cas où cela est possible. Aucune modification suivante au contrat de vente ne sera valide et contraignante sans acte écrit et signé par la partie contre laquelle cette modification est invoquée.
7. Conformément à l'article 1510 du code civil, la livraison des biens vendus se fait par la remise de ceux-ci au transporteur ou à l'expéditionnaire, de sorte que les dits biens voyagent aux risques et périls de l'acheteur; cette règle vaut aussi dans les cas où la marchandise est vendue franco adresse de l'acheteur. Toute éventuelle demande, réclamation et/ou action relative à l'expédition ou au transport de la marchandise devra être faite par l'acheteur directement à l'expéditionnaire ou au transporteur. Les éventuels dommages, perte ou avarie des biens vendus dépendant de leur expédition ou du transport n'exonèrent pas l'acheteur du paiement du prix convenu.
8. La date de livraison est indicative et non péremptoire; elle pourra être retardée sans aucune obligation d'indemnisation ou de dédommagement d'éventuels dommages directs ou indirects subis par l'acheteur à cause de la livraison retardée et sans que cela puisse de toute manière comporter la résiliation du contrat de vente pour inexécution de la venderesse.
9. Sauf les cas de force majeure, en cas de grèves et dans tous les autres cas qui empêchent temporairement la venderesse de remplir normalement le contrat de vente, la venderesse a le droit de résilier le contrat, sans pour autant que ce fait légitime l'acheteur à d'éventuelles prétentions de dommage, sauf, dans l'hypothèse de résiliation, la restitution des sommes éventuellement versées à titre d'acompte.
10. Le paiement du prix de vente des produits devra se faire au siège de la venderesse. En cas de paiement en retard, l'acheteur sera automatiquement mis en demeure et sera tenu de payer des intérêts au taux et dans les délais établis par le décret de loi 231/2002 régissant les retards de paiement dans les transactions commerciales.
11. La venderesse n'est pas responsable des éventuels vices des produits connus ou que l'acheteur aurait pu connaître s'il n'a pas immédiatement refusé la marchandise. Les contestations ou les réclamations sur les quantités des produits doivent être signalées au moment de la livraison, au moyen d'une note écrite sur le document de transport. L'éventuel remplacement du produit ne signifie pas l'acceptation de la contestation ou de la réclamation. Le remboursement de l'acheteur sera fait uniquement après la restitution des produits défectueux et à condition qu'ait été reconnue ou autrement établie la responsabilité de la venderesse.
12. Les dessins, les modèles, les graphiques et les autres informations techniques sur les produits objet de la vente, ainsi que les échantillons, les catalogues, les photos et tout le matériel similaire demeurent toujours la propriété intellectuelle de la venderesse et ne peuvent par conséquent pas être copiés, ni transmis à des tiers, ni utilisés d'aucune autre manière.
13. Les sommes versées à titre d'arrhes de confirmation pourront être retenues par la venderesse en cas de révocation de la commande et/ou dans tout autre cas d'inexécution de l'acheteur justifiant la résiliation par la venderesse, sauf le droit de demander l'exécution du contrat et aussi sauf le droit de demander le dédommagement du dommage supérieur. Au contraire, dans le cas d'exécution par l'acheteur de ses propres obligations contractuelles, les sommes qu'il aura versées à titre d'arrhes de confirmation seront imputées au paiement du prix; celles-ci, ainsi que les éventuels acomptes, ne produiront pas d'intérêts.
14. L'éventuelle tolérance par une des parties des comportements de l'autre en violation des clauses qui régissent la vente ne constitue pas une renonciation aux droits découlant des clauses violées ni au droit d'exiger l'exécution exacte de tous les termes et conditions prévus par le contrat de vente.
15. La venderesse garde la propriété des produits livrés jusqu'au paiement total du prix indiqué dans la facture. Jusqu'à cette date, les produits livrés sont considérés comme seulement déposés chez l'acheteur. Ce dernier prend donc en charge le risque des dommages que les produits déposés pourraient subir qu'ils soient imputables à n'importe quelle cause.
16. L'acheteur est invité à faire particulièrement attention au fait que tous les produits indiqués dans le présent catalogue des prix ne sont pas nécessairement compatibles avec les marchés américain ou canadien. Par conséquent, si l'acheteur a l'intention d'utiliser ou d'exporter les dits produits aux États-Unis et, dans tous les cas, dans n'importe quel autre pays extra UE, il doit préalablement contacter le bureau commercial de la venderesse pour avoir la confirmation que le produit concerné remplit toutes les exigences techniques et est conforme aux standards légaux prévus pour la protection des consommateurs finaux du marché de destination. La venderesse décline toute responsabilité pour des initiatives prises par l'acheteur dont elle n'a pas été préalablement informée et indépendamment de l'éventuelle autorisation écrite de la venderesse pour l'exportation et ou l'emploi du produit dans un pays extra UE.
17. L'acheteur est tenu d'informer ses propres clients et/ou les utilisateurs finaux des caractéristiques du produit afin de réduire au minimum le risque d'emploi impropre qui pourrait exposer la venderesse à d'éventuelles demandes de dédommagement. À défaut de cette activité d'information préventive, l'acheteur exonère expressément la venderesse de toute hypothétique responsabilité.
18. Le vendeur garantit la conformité des produits avec les spécifications indiquées dans la confirmation de la commande, sous réserve des tolérances considérées acceptables pour la production industrielle.
19. Le vendeur ne garantit pas que les produits sont appropriés pour des occasions particulières et/ou des usages spéciaux, sous réserve de demande spécifique de l'acheteur expressément acceptée par écrit par le vendeur et indiquée dans la confirmation de la commande; l'acheteur doit s'assurer que les normes spécifiques éventuelles et/ou les conditions légales exigées soient spécifiées dans la confirmation de la commande de la part du vendeur.
20. Les informations du vendeur sur la pertinence spécifique des produits sont purement indicatives.
21. Toute activité d'assistance et/ou calcul effectuée par le vendeur sur les produits est à considérer comme purement indicative et non contraignante en s'agissant d'un simple conseil sur le positionnement des produits, chaque donnée doit être dument vérifiée par l'acheteur; il est évident qu'en s'agissant de simples suggestions non contraignantes, le vendeur n'assume aucune responsabilité quant aux résultats de ces activités.
22. Etant donné que les utilisations des produits faites par l'acheteur sont en dehors du contrôle du vendeur, ce dernier n'est pas responsable pour l'utilisation effective des produits; le vendeur n'est pas responsable pour d'éventuels dommages et/ou pertes dus à l'utilisation non correcte ou inhabituelle des produits.
23. Compte tenu de la spécificité des produits Snowsound-Fiber, même si le vendeur s'efforce à garder des niveaux de qualité élevé, ont considère comme acceptable trois défauts tous les 25 mètres pour des hauteurs du rouleau jusqu'à 150 cm et le double de défauts pour des rouleaux avec une hauteur supérieure à 280 cm; le vendeur se réserve toujours la faculté d'offrir pour chaque défaut constaté une quantité de matériel estimée apte à compenser les défauts constatés. Nous n'acceptons pas de reprise pour des produits et/ou des pièces coupés sur mesure.
24. L'annulation d'une commande de la part de l'acheteur n'est autorisée qu'en des cas exceptionnels et avec l'accord écrit préalable du vendeur.
25. En cas de commandes de produits et/ou couleurs hors norme l'acheteur est tenu à acheter toute la production effectuée expressément pour lui.
26. Sauf convention contraire et sauf en cas de fraude, la responsabilité du vendeur pour les produits vendus est limitée à un montant égal au triple de la valeur de la confirmation de la commande, même en cas de faute grave.
27. Toutes les controverse qui devraient surgir relatives à la vente, à ses actes de modification et d'exécution, y compris celles concernant la validité, l'efficacité, l'interprétation, l'exécution et la résiliation du contrat, seront du ressort exclusif du Tribunal de Milan.
28. De toute manière, avant de procéder à l'achat des produits, il faut consulter les conditions de vente, les caractéristiques techniques et les autres suivantes:

MISES EN GARDE

- avant de procéder à l'installation des produits, il faut vérifier la portée maximum des murs/ sol/surfaces sur lesquelles les produits seront placés en s'assurant qu'ils soient adaptés au type d'usage et/ou d'utilisation auquel ils sont destinés;
- les produits ne doivent pas être utilisés par les enfants;
- les produits ne doivent pas être utilisés à l'extérieur des bâtiments;
- les produits appliqués aux murs/ sol/surfaces comportent l'installation avec des dispositifs d'ancrage qui ne sont pas montrés dans les illustrations du catalogue;
- les produits doivent être montés et/ou installés exclusivement par du personnel technique compétent en utilisant des instruments et outils prévus à cet effet;
- avant de procéder au montage et à l'installation des produits, il faut lire attentivement les instructions jointes aux produits, en faisant particulièrement attention tant aux instructions qu'aux dessins explicatifs; si les instructions ne sont pas jointes, contacter le bureau technique de la venderesse;
- pour fixer les produits aux murs/sol/surfaces, il faut utiliser des dispositifs de fixation adéquats et en mesure de résister aux forces générées; dans tous les cas il est nécessaire d'utiliser des éléments de soutien adéquats à supporter chaque structure en particulier;
- en cas d'installation non correcte et/ou en cas de dépassement des charges maximales indiquées dans le présent catalogue des prix et/ou dans les instructions jointes à chaque produit, une situation de danger pourrait se créer, les produits pourraient s'effondrer, céder, tomber et causer des dommages aux choses et/ou aux personnes: jamais dépasser les charges indiquées;
- en cas de doutes sur les modes d'installation et/ou sur le maximum de portée des murs/ sol/surface sur lesquels sera placé le produit, ne pas procéder à l'installation;
- s'en tenir aux instructions et aux compositions indiquées dans le présent catalogue des prix; pour des compositions différentes et/ou pour toute information supplémentaire sur les produits ou sur les modes d'installation de ceux-ci, contacter le bureau technique de la venderesse;
- légères différences de couleur entre un lot et l'autre doivent être considérées comme étant normales si dans le limite des tolérances jugées acceptables pour la production industrielle;
- le texte de référence est seulement celui en italien, les traductions ont le seul but de simplifier la lecture.

CONDICIONES DE VENTA

1. Esta lista de precios anula y sustituye las anteriores y no es una oferta.
2. El vendedor puede cambiar los precios de los productos en cualquier momento sin previo aviso; ninguno de los precios incluye el montaje.
3. El vendedor se reserva el derecho de modificar, a su entera discreción y sin previo aviso, los materiales de construcción, las características técnicas y estéticas así como también las dimensiones de los productos.
4. Las imágenes de los productos son meramente ilustrativas.
5. La venta se rige no sólo por las condiciones especiales acordadas caso por caso, sino también por las presentes condiciones generales, que el comprador ha de conocer; posibles cláusulas de exención a lo dispuesto en las presentes condiciones generales de venta deben figurar por escrito.
6. Las propuestas de compra y/o pedidos del comprador dependen de la aceptación o del inicio del contrato por parte del vendedor, en los casos en que esto esté permitido. Cualquier modificación posterior al contrato de venta no será válida ni vinculante si no figura en un contrato escrito, firmado por la parte en relación a la cual se pide dicha modificación.
7. En conformidad con el artículo 1510 del Código Civil, la entrega de los bienes vendidos se considera a partir de la remisión de los mismos al transportista o al agente de transporte, es decir que los bienes viajan a riesgo y peligro del comprador; esto vale también en los casos en los cuales la mercancía haya sido vendida con el transporte pagado hasta la sede del comprador. Cualquier posible petición, queja y/o acción relacionada con el envío o transporte de mercancías deberá ser efectuada por el comprador directamente contra el transportista o agente de transportes. Cualquier posible daño, pérdida o rotura de los bienes vendidos debidos a la expedición o al transporte de los mismos no exime al comprador de pagar el precio convenido.
8. El plazo de entrega es indicativo y no perentorio; el mismo podrá retrasarse sin ninguna obligación de indemnización ni compensación de los daños directos o indirectos sufridos por el comprador por la entrega tardía y sin que esto pueda llevar a la terminación del contrato de venta por incumplimiento del vendedor.
9. Excepto en los casos de fuerza mayor, en caso de huelgas y en los demás casos que impidan temporalmente al vendedor cumplir normalmente con el contrato de venta, el vendedor tendrá el derecho de rescindir el contrato, sin que el comprador pueda presentar ninguna reclamación por daños y perjuicios, salvo en el caso de cancelación, la devolución de lo pagado por adelantado.
10. El pago del precio de venta de los productos debe llevarse a cabo en las instalaciones del vendedor. En caso de demora en el pago, el comprador estará automáticamente en mora y deberá pagar intereses en la medida y con la fecha establecida por el Decreto Legislativo. 231/2002 de la morosidad en las transacciones comerciales
11. El vendedor no se hace responsable por posibles defectos de los productos identificados o identificables por parte del comprador, que no haya rechazado inmediatamente. Cualquier disputa o queja sobre las cantidades de productos deben ser indicadas en el momento de la entrega, con la anotación en el documento de transporte correspondiente. La posible sustitución del producto no implica la aceptación de la objeción o queja. El pago al comprador se realizará sólo una vez efectuada la devolución de los productos defectuosos y siempre que se haya reconocido o comprobado la responsabilidad del vendedor.
12. Los dibujos, modelos, diagramas y otra información técnica de los productos vendidos, así como las muestras, catálogos, fotografías y otros materiales similares, siguen siendo de propiedad intelectual del vendedor y no pueden ser copiados ni transmitidos a otras personas ni utilizarse de otro modo.
13. Las sumas abonadas en concepto de señal confirmatoria podrán ser retenidas por el vendedor en caso de revocación del pedido y/o ante cualquier otro caso de incumplimiento por parte del comprador que justifique la retirada del vendedor, salvo el derecho a exigir el cumplimiento del contrato y también el derecho a reclamar indemnización por daños y perjuicios adicionales. Por el contrario, en el caso de cumplimiento por parte del comprador de sus obligaciones contractuales, las cantidades pagadas en concepto de señal confirmatoria serán consideradas con el pago del precio; las mismas, así como también los pagos iniciales, serán de todos modos sin intereses.
14. Cualquier tolerancia de una de las partes a conductas iniciadas en violación de las disposiciones que rigen la venta no constituirá una renuncia a derechos que se deriven de las disposiciones violadas o el derecho a exigir el estricto cumplimiento de todos los términos y condiciones establecidos en contrato de venta.
15. El vendedor conserva la propiedad de los bienes entregados hasta el pago total del precio indicado en la factura. Hasta esa fecha, los productos entregados han de considerarse sólo como bienes depositados en la sede del comprador. Por lo tanto, este último se asume el riesgo por los daños que los mismos puedan sufrir debidos a cualquier causa.
16. El comprador ha de prestar especial atención al hecho de que no todos los productos que figuran en este catálogo son compatibles con el mercado de los EE.UU. o de Canadá. Por lo tanto, si el comprador tiene la intención de utilizar o exportar dichos productos en los Estados Unidos de América y/o, de todos modos, en cualquier otro país fuera de la UE, debe antes y imperativamente ponerse en contacto con la oficina de ventas del vendedor para confirmar que el producto en cuestión cumpla con todos los requisitos técnicos y las normas establecidas en la legislación para proteger a los consumidores en el mercado de destino. El vendedor no se asume ninguna responsabilidad con respecto a las iniciativas adoptadas por el comprador, sin haber sido informado previamente e independientemente de la posible autorización por escrito por parte del vendedor a la exportación y/o uso del producto en un país fuera de la UE.
17. El comprador está obligado a informar a sus clientes y/o usuarios finales de las características del producto para reducir al mínimo el riesgo de mal uso que podría exponer al vendedor a posibles motivos de daño. En ausencia de dicha actividad de información preventiva, el comprador libera expresamente al vendedor de cualquier responsabilidad hipotética.
18. El vendedor garantiza la conformidad de los productos a las especificaciones mencionadas en la confirmación del pedido, excepto las tolerancias que se consideren aceptables para la producción industrial.
19. El vendedor no garantiza la idoneidad de los productos para fines especiales y/o usos específicos, a menos que el comprador no la haya pedido de forma específica y que el vendedor la haya aceptado expresamente por escrito constando en la correspondiente confirmación del pedido; el comprador debe comprobar que las posibles normas específicas y/o requisitos legales exigidos consten en la correspondiente confirmación del pedido del vendedor
20. La información que facilita el vendedor con respecto a la idoneidad específica de los productos es meramente indicativa.
21. . De haber una actividad de asesoramiento y/o cálculo realizada por el vendedor sobre los productos, se la deberá considerar solamente indicativa y no vinculante siendo una mera sugerencia sobre el posicionamiento general de los productos, en cualquier caso le incumbirá al comprador controlar detalladamente cada uno de los datos propuestos; es evidente que el vendedor por tratarse de meras sugerencias no vinculantes, no asume responsabilidad alguna con respecto a los resultados de dicha actividad.
22. Puesto que el vendedor no puede controlar cómo el comprador emplea el producto, el vendedor no se hace responsable por el uso concreto de los productos; el vendedor no se hace responsable por los posibles daños y/o perjuicios debidos al uso incorrecto o extraño de los productos.
23. Habida cuenta de la especificidad de los productos Snowsound-Fiber, si bien el vendedor hace todo lo que está en su poder por mantener elevados niveles de calidad, considera aceptables tres defectos cada 25 metros de rollo alto hasta 150 cm y el doble de defectos por rollo alto más de 280 cm; sin embargo, el vendedor se reserva la facultad de descontar por cada defecto detectado una cantidad de material que considere adecuada a compensar los defectos comprobados. No se aceptan devoluciones de productos y/o tejidos cortados a medida.
24. El comprador podrá cancelar un pedido sólo en casos excepcionales y previo consentimiento expreso por escrito por parte del vendedor.
25. En el caso de pedidos de productos y/o colores no estándar, el comprador deberá comprar toda la producción realizada específicamente.
26. Salvo acuerdo contrario y salvo el caso de dolo, la responsabilidad del vendedor por los productos vendidos se limita a un importe igual a tres veces el valor de la confirmación del pedido, también si hubiera culpa grave.
27. Todas las controversias que pudiesen surgir en relación con la venta, documentos modificativos y ejecutivos, incluidas las relativas a la validez, eficacia, interpretación, ejecución y terminación del contrato, serán resueltas exclusivamente por el Tribunal competente de Milán.
28. De todos modos, antes de comprar los productos es necesario leer las condiciones de venta, las especificaciones técnicas y además las siguientes:

ADVERTENCIAS

- antes de instalar los productos es necesario controlar las características de la pared/piso/superficie en donde se colocarán dichos productos, asegurándose que sean adecuados al tipo de usuario y/o de uso final;
- los productos no son adecuados para ser utilizados por niños;
- los productos no son adecuados para ser utilizados al aire libre;
- los productos aplicados a la pared/piso/superficie prevén el uso de dispositivos de anclaje que no están ilustrados en el catálogo;
- los productos deben ser montados y/o instalados exclusivamente por personal técnico cualificado utilizando los instrumentos y las herramientas específicas para dicho fin;
- antes de montar y instalar los productos es necesario leer atentamente las instrucciones adjuntas a los productos, prestando especial atención tanto a las advertencias como a los diseños de explicación; si faltan las instrucciones, póngase en contacto con la oficina técnica del vendedor;
- para fijar los productos a la pared/piso/superficies es necesario utilizar los dispositivos de sujeción adecuados capaces de resistir a las fuerzas generadas; se debe de todas formas utilizar elementos de soporte capaces de sostener cada una de las estructuras;
- en caso de montaje incorrecto y/o en caso de un exceso de las cargas máximas especificadas en la presente lista y/o en las instrucciones adjuntas a cada producto, se podría crear una situación de peligro, los productos podrían colapsar, ceder, caer y causar daños a cosas y/o personas; no exceder nunca las cargas indicadas;
- en caso de dudas acerca de cómo efectuar la instalación y/o de las características de la pared /piso/superficie sobre el cual será montado el producto, no lleve a cabo la instalación;
- siga las instrucciones y elija las combinaciones que figuran en esta lista; para combinaciones diferentes y/o otras informaciones sobre los productos o sobre el modo de instalación de los mismos, póngase en contacto con la oficina técnica del vendedor.
- - Ligeras diferencias de color entre un lote y otro deben considerarse normales de cumplirse las tolerancias que se consideren aceptables para la producción industrial;
- El texto auténtico es exclusivamente lo en idioma italiano, las traducciones tienen el único propósito de simplificar la lectura.

ALLGEMEINE VERKAUFSBEDINGUNGEN

1. Die vorliegende Preisliste hebt alle vorausgegangenen Listen auf, ersetzt sie und stellt kein Angebot dar.
2. Die Preise der Produkte können vom Verkäufer jederzeit ohne entsprechende Benachrichtigung geändert werden; keiner der Preise enthält die Montagekosten.
3. Der Verkäufer behält sich das Recht vor, nach seinem eigenen, unanfechtbaren Urteil und ohne entsprechende Benachrichtigung, Materialbeschaffenheit, technische Eigenschaften und Aussehen sowie die jeweiligen Abmessungen der Produkte zu ändern.
4. Die Produktbilder haben reinen Beispielcharakter.
5. Abgesehen von fallweise ausgehandelten Sonderkonditionen wird der Verkauf von den vorliegenden allgemeinen Bedingungen geregelt, von denen vorausgesetzt wird, dass der Käufer sie kennt; eventuell von den in den vorliegenden allgemeinen Verkaufsbedingungen abweichende Klauseln bedürfen jeweils der schriftlichen Form.
6. Die Kaufanbote und/oder Aufträge des Käufers bedürfen zuvor der ausdrücklichen Annahme bzw. in Fällen, in denen dies gestattet ist, des Beginns der Vertragserfüllung seitens des Verkäufers. Jegliche nachträgliche Änderung des Kaufvertrages ist nicht gültig und bindend, sofern nicht entsprechende schriftliche und jeweils von der Partei, die diese Änderung annehmen soll, unterzeichnete Unterlagen vorliegen.
7. Gemäß Art. 1510 Italienisches Bürgerliches Gesetzbuch (Codice Civile) findet die Lieferung der verkauften Waren bei deren Abgabe an den Transportunternehmer bzw. den Spediteur statt, so dass die Waren auf Risiko und Gefahr des Empfängers reisen; dies gilt auch in den Fällen, in denen die Ware frei Haus verkauft wird. Jeglicher Anspruch, Reklamation und/oder Klage betreffend die Lieferung oder den Transport der Waren muss vom Kunden direkt an den Transportunternehmer oder Spediteur gerichtet werden. Jeder eventuelle Schaden, Verlust oder Defekt der verkauften Waren, der durch den Versand bzw. Transport verursacht wurde, befreit den Käufer nicht von der Pflicht, den vereinbarten Kaufpreis zu zahlen.
8. Der Liefertermin gilt als ungefähre Angabe und ist nicht bindend; er kann sich verzögern, ohne dass eine Ersatz- oder Entschädigungspflicht für eventuelle direkte oder indirekte, vom Käufer infolge der verspäteten Lieferung erlittenen Schäden besteht und ohne dass dies zur Auflösung des Verkaufsvertrags aufgrund von Nichterfüllung des Verkäufers berechtigt.
9. Mit Ausnahme von Fällen höherer Gewalt, bei Streiks oder in allen anderen Fällen, durch die der Verkäufer vorübergehend außerstande ist, den Verkaufsvertrag ordnungsgemäß zu erfüllen, hat der Verkäufer das Recht, vom Vertrag zurückzutreten, ohne dass der Käufer berechtigt ist, eventuelle Schadensersatzansprüche zu stellen, mit Ausnahme der Rückzahlung einer allfälligen Anzahlung im Falle eines Rücktritts.
10. Die Zahlung des Verkaufspreises der Produkte hat direkt an den Sitz des Verkäufers zu erfolgen. Bei verspäteter Zahlung befindet sich der Käufer automatisch in Verzug und ist verpflichtet, Zinsen in dem von der Gesetzesverordnung 231/2002 über Zahlungsverzögerungen bei Handelsgeschäften festgelegten Umfang sowie mit den entsprechenden Fristen zu zahlen.
11. Der Verkäufer haftet nicht für eventuelle dem Käufer bekannte oder erkennbare Mängel, wenn dieser die Ware nicht umgehend zurückgewiesen hat. Beanstandungen oder Reklamationen in Bezug auf Produktmengen müssen jeweils bei Auslieferung gemeldet und auf den entsprechenden Transportunterlagen vermerkt werden. Der eventuelle Ersatz des Produkts ist dabei nicht gleichbedeutend mit einer Akzeptanz der Beanstandung oder Reklamation. Die entsprechende Gut-schrift für den Verkäufer erfolgt erst nach Rückgabe der mangelhaften Produkte und unter der Voraussetzung, dass die Verantwortung des Käufers anerkannt oder anderweitig festgestellt wurde.
12. Die Zeichnungen, Modelle, Darstellungen und anderen technischen Informationen über die Produkte, die den Gegenstand des Verkaufs bilden, ebenso wie die Muster, Kataloge, Photos und ähnlichen Materialien bleiben immer geistiges Eigentum des Verkäufers und dürfen daher weder kopiert, noch anderen überlassen oder in irgendeiner anderen Form genutzt werden.
13. Die als Anzahlung zur Bestätigung entrichteten Beträge können vom Verkäufer bei Annullierung des Auftrags und/oder in jedem anderen Fall einer Nichterfüllung seitens des Käufers einbehalten werden, die den Rücktritt des Verkäufers rechtfertigt, vorbehaltlich des Rechts, die Erfüllung des Vertrags zu verlangen und ebenso vorbehaltlich des Rechts, die Entschädigung eines darüber hinausgehenden Schadens zu verlangen. Umgekehrt werden im Fall der Erfüllung der Vertragsverpflichtungen seitens des Käufers die von diesem als Anzahlung zur Bestätigung entrichteten Beträge auf den Kaufpreis angerechnet; diese Beträge gelten auf jeden Fall, ebenso wie alle anderen Vorauszahlungen, als unverzinslich.
14. Die eventuelle Hinnahme einer der Parteien von Verhaltensweisen der anderen Vertragspartei, durch die die Verkaufsbedingungen verletzt werden, stellt keinen Verzicht auf sich aus verletzten Klauseln ergebende Rechte dar, noch auf das Recht, die korrekte Erfüllung aller Fristen und Bedingungen zu verlangen, die vom Kaufvertrag vorgesehen sind.
15. Der Verkäufer behält das Eigentumsrecht an den gelieferten Produkten bis zur vollständigen Zahlung des jeweils in der Rechnung angegebenen Preises. Bis zu diesem Datum gelten die gelieferten Produkte nur als beim Verkäufer hinterlegt. Dieser letztere übernimmt daher auch das Risiko für Schäden, die an den hinterlegten Produkten aus irgendeinem Grund entstehen könnten.
16. Der Käufer wird aufgefordert, besondere Aufmerksamkeit darauf zu verwenden, dass nicht alle in dieser Preisliste angegebenen Produkte mit dem amerikanischen oder kanadischen Markt vereinbar sind. Daher ist der Käufer, falls er vorhat die genannten Produkte in die USA und/oder in irgendein Nicht-EU-Land zu exportieren, verpflichtet, sich jeweils vorher an die Handelsabteilung des Verkäufers zu wenden, um die Bestätigung zu erhalten, dass das betreffende Produkt allen technischen Erfordernissen und den gesetzlichen Vorschriften entspricht, die zum Schutz des Endverbrauchers in dem jeweiligen Bestimmungsmarkt vorgesehen sind. Der Verkäufer übernimmt dabei keine Verantwortung für vom Käufer ergriffene Initiativen, wenn er nicht vorher darüber in Kenntnis gesetzt worden ist und unabhängig von der eventuellen schriftlichen Genehmigung des Verkäufers zum Export und/oder zur Verwendung des Produkts in einem Nicht-EU-Land.
17. Der Käufer ist verpflichtet, seine Kunden und/oder Endverbraucher über die Eigenschaften des Produkts in Kenntnis zu setzen, um die Gefahr von deren missbräuchlichen Verwendung, die den Verkäufer möglichen Schadensansprüchen aussetzen könnte, auf ein Mindestmaß zu reduzieren. In Ermangelung dieser vorherigen Informationstätigkeit befreit der Käufer den Verkäufer ausdrücklich von jeder möglichen Verantwortung.
18. Die verkaufende Gesellschaft garantiert, dass die Produkte die in der Bestellbestätigung enthaltenen technischen Spezifikationen einhalten, unbeschadet der von der industriellen Fertigung als akzeptabel angesehenen Abweichungen.
19. Die verkaufende Gesellschaft garantiert nicht die Eignung der Produkte zu spezifischen oder Sonderzwecken oder besonderen Verwendungen, außer in dem Fall, wo eine entsprechende Anfrage seitens des Käufers ausdrücklich schriftlich vom der verkaufenden Gesellschaft bestätigt wurde, und dies auf der Bestellbestätigung erwähnt wird. Der Käufer muss sicherstellen, dass eventuell erforderliche spezifische Standards und/oder rechtliche Anforderungen in der entsprechenden Bestellbestätigung seitens der verkaufenden Gesellschaft ausdrücklich enthalten sind.
20. Die von der verkaufenden Gesellschaft gelieferten Informationen zur spezifischen Eignung von Produkten haben reinen Beispielwert.
21. Eventuell von der verkaufenden Gesellschaft geleistete Hilfs- und/oder Berechnungsdienste müssen als reine Orientierungshilfe und als unverbindlich bewertet werden, denn sie liefern eine bloße allgemeine Empfehlung zur Positionierung der Produkte und müssen jedenfalls vom Käufer vollständig geprüft werden; selbstverständlich übernimmt die verkaufende Gesellschaft, da es sich um bloße unverbindliche Empfehlungen handelt, keine Haftung für eventuell aus der inkorrekten oder ungewohnten Anwendung der Produkte entstehende Schäden und/oder Verluste.
22. Da die Anwendung der Produkte seitens des Käufers nicht im Kontrollbereich der verkaufenden Gesellschaft liegen, ist letztere für die tatsächliche Anwendung der Produkte nicht verantwortlich; die verkaufende Gesellschaft übernimmt keine Haftung für eventuell aus der inkorrekten oder ungewohnten Anwendung der Produkte entstehende Schäden und/oder Verluste.
23. Angesichts der Besonderheit von Snowsound-Fiber-Produkten, und obwohl die verkaufende Gesellschaft um die Einhaltung von hohen Qualitätsstandards bestrebt ist, sind bei einer Rollenhöhe von 150cm 3 Fehler alle 25 Meter und bei einer Rollenhöhe über 280 cm das Doppelte als annehmbar anzusehen. Die verkaufende Gesellschaft behält sich jedenfalls das Recht vor, für jeden festgestellten Fehler eine zur Kompensation der festgestellten Fehlerhaftigkeit geeignete Quantität an Material herabzusetzen. Die Rückgabe von zugeschnittenen Produkten und/oder Produktteilen wird nicht akzeptiert.
24. Der Widerruf einer Bestellung seitens des Käufers ist nur in Ausnahmefällen und nach schriftlicher Zustimmung der verkaufenden Gesellschaft zulässig.
25. Im Falle der Bestellung von vom Standard abweichenden Produkten und/oder Farben ist der Käufer dazu angehalten, die gesamte eigens dazu hergestellte Produktmenge anzukaufen.
26. Wenn nicht anders abgemacht und unbeschadet des Falls der vorsätzlichen Täuschung, beschränkt sich die Haftung der verkaufenden Gesellschaft für die verkauften Produkte auf einen sich auf das Dreifache des Bestellbestätigung-s-Werts belaufenden Betrag, selbst im Falle der schweren Schuld.
27. Sämtliche Streitfragen, die sich im Zusammenhang mit dem Verkauf, sowie sämtlichen Änderungen, einschließlich derer in Bezug auf die Gültigkeit, Wirksamkeit, Auslegung, Durchführung und Auflösung des Vertrags ergeben können, unterliegen der ausschließlichen Zuständigkeit des Gerichtsstands von Mailand (Italien).
28. Auf jeden Fall müssen vor Kauf der Produkte jeweils die Verkaufsbedingungen, die technischen Eigenschaften sowie folgende weitere:

HINWEISE

berücksichtigt werden:

- Vor der Installation der Produkte muss die Tragfähigkeit der Wand/des Bodens/der Fläche überprüft werden, an der/auf dem die Produkte angebracht werden sollen, wobei kontrolliert werden muss, ob sie der Art der Benutzer/Verwendung entsprechen, für die sie vorgesehen sind.
- Die Produkte sind nicht für Kinder geeignet.
- Die Produkte sind nicht für die Verwendung im Außenbereich geeignet.
- Die an der Wand/am Boden/ der Fläche montierten Produkte sehen eine Installation mit Verankerungsvorrichtungen vor, die nicht in den Abbildungen des Katalogs gezeigt werden.
- Die Produkte dürfen ausschließlich durch technisches Fachpersonal montiert und/oder installiert werden, wobei jeweils entsprechend geeignete Geräte und Ausrüstung verwendet werden müssen.
- Vor der Montage und Installation der Produkte muss die den Produkten beiliegende Gebrauchsanweisung aufmerksam durchgelesen werden, wobei besonders die Hinweise und die entsprechenden erklärenden Zeichnungen beachtet werden müssen; sollte die Gebrauchsanweisung nicht beiliegen, wenden Sie sich bitte an die technische Abteilung des Verkäufers.
- Um die Produkte an Wand/Boden/Oberflächen zu befestigen, müssen geeignete Beschläge verwendet werden, die in der Lage sind, die auf diese Weise erzeugten Kräfte auszuhalten; auf jeden Fall müssen passende Halterungen verwendet werden, die jedes einzelne Element tragen können.
- Bei nicht vorschriftsmäßiger Installation und/oder im Fall der Überschreitung der in der vorliegenden Preisliste und/oder den jedem einzelnen Produkt beiliegenden Gebrauchsanweisungen angegebenen Höchstlasten könnten sich Gefahrensituationen ergeben, die Produkte könnten kollabieren, nachgeben, herunterfallen und Sach- und/oder Personenschäden verursachen: die angegebenen Lasten daher nie überschreiten.
- Bei Zweifeln in Bezug auf die Art der Installation und/oder die jeweilige Tragfähigkeit der Wand/des Bodens/der Fläche, an der/auf dem das Produkt angebracht werden soll ist, nicht mit der Installation beginnen.
- Halten Sie sich an die in der vorliegenden Preisliste enthaltenen Anweisungen und Zusammenstellungen halten; bei anderweitigen Zusammenstellungen und/oder für nähere Informationen über die Produkte und die Art ihrer Installation wenden Sie sich bitte an die technische Abteilung des Verkäufers.
- Leichte Farbunterschiede zwischen zwei Partien sind unter Wahrung der für Industrieproduktion als zulässig betrachteten Abweichungen als normal zu anzusehen.- Es ist ausschließlich der italienische Text verbindlich, die Übersetzungen dienen lediglich der vereinfachten Lesbarkeit.

Caimi Brevetti S.p.A. si riserva, a proprio insindacabile giudizio, la facoltà di modificare senza preavviso i materiali costruttivi, le caratteristiche tecniche ed estetiche, nonché le dimensioni degli elementi illustrati nel presente listino le cui immagini e colori sono puramente indicativi.

Caimi Brevetti S.p.A. reserves, by its unappealable judgment, the right to modify without prior notice the building materials, the technical and aesthetic specifications, as well as the dimensions of the products in this price list, where pictures and Colors are purely as an indication.

Caimi Brevetti S.p.A. se réserve, à son jugement sans appel, la faculté de modifier sans aucun préavis les matériaux de construction, les caractéristiques techniques et esthétiques ainsi que les dimensions des éléments illustrés dans ce tarif, dont les images et couleurs sont seulement indicatifs.

Caimi Brevetti S.p.A. se reserva, a su indiscutible juicio, el derecho a modificar sin previo aviso los materiales de construcción, las características técnicas y estéticas, así como las medidas de los productos del presente lista de precios, donde las imágenes y los colores son meramente indicativos.

Caimi Brevetti S.p.A. behält sich das Recht vor, ihrer unkontrollierbaren Meinung nach, verwendete Materialien, technische und ästhetische Änderungen sowie die Abmessungen der in dieser Preisliste abgebildeten Produkte ohne vorherige Ankündigung zu ändern. Die gezeigten Fotos und deren Farben dienen ausschliesslich zur ungefähren Information.

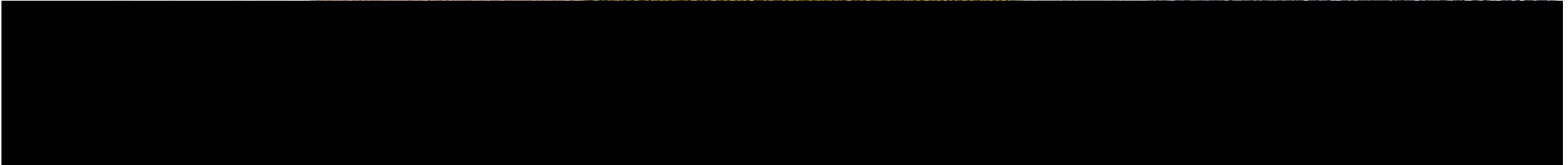

www.caimi.com